



LIBRARY
ROYAL AIRCRAFT ESTABLISHMENT
BEDFORD.

MINISTRY OF AVIATION

AERONAUTICAL RESEARCH COUNCIL

CURRENT PAPERS

Measurement of the Moments of
Inertia of the Handley Page
HP115 Aircraft

by

L. J. Fennell, B.Sc., A.F.R.Ae.S.

LONDON. HER MAJESTY'S STATIONERY OFFICE

1967

PRICE 9s 6d NET

AIRFIELD LIBRARY

To: MR Hobday Aero/F D.O.

The attached was requested by you:-

a. ~~For retention~~

b. Please return to this Library by:

4/11/74

If a retention copy is required notify Airfield
Library as soon as possible.

Thank you.

MEASUREMENT OF THE MOMENTS OF INERTIA OF
THE HANDLEY PAGE HP115 AIRCRAFT

by

L. J. Fennell, B.Sc. A.F.R.Ae.S.

SUMMARY

Measurement of the moments of inertia in pitch, roll, and yaw, and of the inclination of the principal inertia axis have been made on the HP115 slender wing research aircraft. In pitch and roll a spring constrained oscillatory technique was used, while in yaw the aircraft was suspended as a torsional pendulum. The inclination of the principal inertia axis was found by varying the attitude of the aircraft on the rolling and yawing rigs. Measurements were made with fuel tanks full and empty.

An estimate of the accuracies of the techniques used showed that the inertias could be measured to within $\pm 2\%$, $\pm 5\%$ and $\pm 1\%$ for the pitch, roll, and yaw axes respectively. The inclination of the principal axes could be determined to within $\pm 0.1^\circ$.

After allowing for the virtual inertia of the surrounding air mass, the experimental values were less than the manufacturers estimates in pitch and roll but greater in yaw. The largest discrepancy was approximately 5%. The measured inclination of the principal axis was considerably less than the estimate, 3.95° instead of 5.1° .

CONTENTS

	<u>Page</u>	
1	INTRODUCTION	3
2	TEST METHODS	4
	2.1 Position of the centre of gravity	4
	2.2 Moment of inertia in roll	5
	2.3 Moment of inertia in pitch	7
	2.4 Moment of inertia in yaw	8
	2.5 Aerodynamic or virtual inertia	10
3	RESULTS	11
	3.1 Centre of gravity	11
	3.2 Moment of inertia in roll	11
	3.3 Moment of inertia in pitch	13
	3.4 Moment of inertia in yaw	14
4	DISCUSSION OF ESTIMATED AND EXPERIMENTAL VALUES	15
	4.1 Aircraft weight and o.g. position	15
	4.2 Moment of inertia of the fuel	17
	4.3 Moment of inertia in roll	17
	4.4 Moment of inertia in pitch	18
	4.5 Moment of inertia in yaw	18
	4.6 $A_{\circ} + B_{\circ} - C_{\circ}$	18
	4.7 Inclination of principal inertia axis	19
5	MOMENTS OF INERTIA FOR FLIGHT TEST RESULTS	19
6	CONCLUSIONS	20
	Acknowledgements	21
	Appendix A Deviation of roll equation of motion	22
	Appendix B Deviation of pitch equation in motion	23
	Appendix C Deviation of yaw equation of motion	24
	Appendix D Error analysis	25
	Table 1 Summary of results	26
	Table 2 Moments of inertia in roll	27
	Table 3 Moments of inertia in pitch	28
	Table 4 Moments of inertia in yaw	28
	Table 5 Moments of inertia for flight test analysis	29
	Table 6 Typical measurements and possible errors	31
	Symbols	33
	References	34
	Illustrations	Figures 1-15
	Detachable abstract cards	-

1 INTRODUCTION

In the determination of aircraft stability derivatives from the analysis of a programme of flight manoeuvres, the accuracy of the results obtained will depend on the values used for the aircraft's moments of inertia and for the orientation of its principal inertia axis.

Estimates of the moment of inertia are customarily made by the manufacturer during the design and construction of the aircraft. Such estimates are liable to errors because of the impracticability of accounting for every component, difficulties in the precise determination of the moments of inertia and centre of gravity positions of intricate parts, and departures from the nominal gauges of the sheet and strip from which the airframe is fabricated.

Experimental confirmation of the predicted values of the moments of inertia is therefore highly desirable; for an aircraft intended for research into flight dynamics it is essential. The HP115 (Fig.1) was specifically designed for such research and was the first member of the "slender wing" class to be built in this country. It is also inertially slender, with a ratio of yawing to rolling inertia of approximately 13:1.

Because of its configuration, with a single engine above the rear fuselage and a low mounted cockpit nacelle, the principal inertia axis on this aircraft is inclined to the fuselage datum line at the relatively large angle of 4° nose down. More usual values lie between 1° and 2° (for example, in the Fairey Delta 2, a moderately slender aircraft, the principal inertia axis is inclined approximately 1.5° nose down relative to the fuselage centre line).

The inclination of the principal inertia axis is of particular importance in inertially slender aircraft because of its influence on the lateral behaviour, since the dominant lateral mode for such aircraft consists of a rolling-motion about the principal inertia axis¹.

Accurate determination of the moments of inertia and inclination of the principal axis of inertia was therefore of particular importance, and various jacking and slinging points were incorporated in the design of the aircraft to facilitate the experimental work described here.

The technique used for determining the moments of inertia in pitch and roll was that (already used for other aircraft^{2,3}) of mounting the aircraft on knife edges so that it could oscillate about a horizontal axis against a spring restraint. The moment of inertia could then be determined from the frequency of oscillation of the system.

On previous occasions yaw inertia rigs have used torsionless single point suspension with spring restraint², or a bifilar torsional pendulum.

NASA have also successfully used an adaptation⁴ of the single point suspension system for determining the inclination of the principal inertia axis.

Both these techniques have the disadvantage of allowing oscillations in modes other than yawing, and on this account an attempt in this country² to determine the principal axis inclination by the NASA method was unsuccessful.

It was therefore decided to adopt a trifilar torsional pendulum system. This technique effectively prevents oscillation in roll and pitch, although lateral and longitudinal motions are still possible; by taking care when displacing the system from rest such motions can be reduced to negligible amounts, and any significant movement readily detected as described in Section 3.4.

Provision was made in both the roll and yaw rigs to vary the pitch attitude of the aircraft relative to the axis of rotation. By measuring the moment of inertia over a range of pitch attitude, the principal moments of inertia could be determined, as the maximum or minimum values, while the associated values of pitch attitude gave the inclination of the principal axis to the fuselage datum.

It was expected that the fuel load would only make a significant contribution to the total moment of inertia in the roll case, but that this would also be the case most susceptible to sloshing of the fuel when the tanks were only partially filled. Attempts^{2,3} have previously been made to measure the moment of inertia in roll of other aircraft with partially filled tanks, but these have not been entirely successful since, due to sloshing, the moment of inertia apparently varied with the frequency of oscillation.

It was therefore decided to determine the moments of inertia with tanks full and tanks empty only, and to estimate values with part fuel loads when these cases were needed to evaluate flight test results. The results in Table 1 show that the inertia of the fuel is a small percentage of the total in pitch and yaw but is equivalent to 12% of the aircraft empty value in roll.

As an essential preliminary to the moment of inertia measurements, the aircraft was weighed and the horizontal and vertical co-ordinates of the centre of gravity were determined. These are also given in Table 1.

2 TEST METHODS

2.1 Determination of the position of the centre of gravity

With the aircraft resting on its undercarriage the vertical reactions at the nose and main wheels will vary as the pitch attitude is changed.

The relation between these reactions and the horizontal distances between the main wheels, nose wheel, and aircraft datum is, (Fig.2),

$$(R_N + R_M) (\hat{x} \cos \alpha + \hat{z} \sin \alpha) + R_N (d_2 - d_1) - R_M d_1 = 0 \quad (1)$$

whence
$$[d_1 - d_2 R_N / (R_N + R_M)] \cdot \sec \alpha = \hat{x} + \hat{z} \tan \alpha \quad (2)$$

where R_N and R_M are the reactions at the nose wheel and main wheels, d_1 is the horizontal distance between the datum point and the main wheels, and d_2 is that between the nose and main wheels; α is the pitch attitude, \hat{x} and \hat{z} are the co-ordinates of the centre of gravity referred to axes parallel and normal to the fuselage datum (Fig.1), and whose origin is at the datum point. R_N and R_M were measured on separate weighbridges whose relative heights could be varied in order to change α . The attitude, α , was measured by a clinometer mounted on the datum pads inside the fuselage.

The aircraft datum point used was located on the fuselage undersurface 21 in below the datum line at fuselage station 278. It was 266 in aft of the fuselage nose or 248 in aft of the wing apex.

2.2 Measurement of the moment of inertia in roll

The rig used is shown in Figs.3 and 14. It consisted of a rigid framework secured to the hangar floor and a variable incidence cradle in which the fuselage rested. The framework carried Vee blocks at its fore and aft ends to support corresponding knife edges mounted on the underside of the cradle. A horizontal, longitudinal axis was thus set up below the aircraft centre line, about which the cradle and aircraft could roll. This rotation was restrained by tension springs attached between the jacking points under each wing and strong points in the floor. To remove one source of constraint the attachment of the springs to the wings was made through pairs of crossed knife-edges (Fig.4).

The cradle consisted of two parts hinged together at the rear and connected to each other by a screwjack at the front. The lower member carried the knife-edges and remained horizontal, while the upper member carried the aircraft at attitudes determined by the extension of the screwjack.

The equation of motion of the system (see Fig.5 and Appendix A) when displaced through a small angle γ is

$$-A_1 \ddot{\gamma} = \gamma [2\lambda y^2 - 2Th_1 (1 - h_1/\ell) - Wh_2] \quad (3)$$

whence

$$A_1 = (P/2\pi)^2 [2\lambda y^2 - 2Th_1 (1 - h_1/\ell) - Wh_2] \quad (4)$$

where A_1 is the moment of inertia of the aircraft and test rig about the knife-edges, P the period of oscillation, y the spring arm about the roll axis, λ the spring rate, T the initial tension in each spring, h_1 the distance of the free end of the spring above the axis, h_2 the height of the c.g. above the axis, ℓ the distance between the upper and lower spring attachments and W the weight of the moving system.

P was determined by timing 50 oscillations using a calibrated stopwatch, λ was determined experimentally by measuring the spring extension with a dial gauge, reading to 0.001 in, as the spring was loaded with a set of weighed ballast blocks. T was calculated from the measured spring length using the load-extension curve, while W consisted of the sum of the aircraft weight, the measured weights of the cradle, knife-edge assemblies, and 1/3 of the spring weight. h_1 , y and ℓ were measured directly while h_2 was found by measuring the height of the aircraft datum point above the roll axis and adding the height of the c.g. which was computed from the results of Section 3.1 and the aircraft pitch attitude. The latter was measured using a clinometer mounted on the aircraft datum setting pads inside the fuselage.

From the value of A_1 thus obtained must be subtracted the inertia of the test rig, the appropriate axis transfer terms, and the inertia of the air moving with the aircraft.

On the right hand side of equation (3) the first term inside the bracket represents the spring moment, while the other two terms take account of the varying moments of the spring tension and weight of the aircraft as the system is displaced.

The aircraft was oscillated in roll at various angles of pitch attitude (α) and the moments of inertia (A) of the aircraft about a horizontal axis through the c.g. at these attitudes determined.

The relation between the principal moments of inertia A_0 and C_0 and the moment of inertia A about an axis other than the principal is

$$A = A_0 \cos^2 (\epsilon_0 - \alpha) + C_0 \sin^2 (\epsilon_0 - \alpha) \quad (5)$$

where ϵ_0 is the inclination of the principal axis to the fuselage datum and α is the inclination of the fuselage datum to the roll axis. This relationship

has a minimum value at $\varepsilon_0 = \alpha$ and the results for A were plotted against the corresponding values of α to obtain A_0 (Fig.10). This curve had a flat minimum, and to obtain a more precise value for ε_0 than could be derived from Fig.10, equation (5) was rewritten as

$$A = A_0 + (C_0 - A_0) \sin^2 (\varepsilon_0 - \alpha) \quad (6)$$

Various trial values of ε were assumed and, by using the experimental data for A and α , a series of graphs showing A as a function of $\sin^2 (\varepsilon - \alpha)$ were plotted, as in Figs.11 and 12.

When the assumed value of ε did not correspond to the true value, ε_0 , the experimental data fell onto two distinct curves according to whether $\alpha - \varepsilon > 0$. When $\varepsilon = \varepsilon_0$, however, all the values were disposed about a single straight line.

Although the slope of the latter will give the principal moment of inertia in yaw, C_0 , it was thought desirable to determine C_0 directly by an independent method, as described in Sections 2.4 and 3.4.

2.3 Measurement of the moment of inertia in pitch

The test rig is shown in Fig.7. To provide an axis parallel to the aircraft pitching axis, knife edge blocks were attached to the underwing jacking points and were supported in Vee blocks mounted on heavy jacks. A steel channel, supported on a second pair of heavy duty jacks, spanned the front fuselage and was joined by tension springs to a second, shorter, steel channel passing beneath the cockpit. A standard jack head on this lower channel engaged with the forward jacking socket under the fuselage. In order to reduce constraints, the crossed knife-edges of the roll rig (Fig.4) were again used between the springs and the lower channel member.

The rig was set up so that the aircraft datum was horizontal in the equilibrium position, both longitudinally and laterally, by adjusting the heights of the appropriate jacks.

The equation of motion of the system is (see Appendix B and Fig.6),

$$-B_1 \ddot{\phi} = \phi [\lambda x^2 - Th_1 (1 - h_1/\ell) + Wh_2] \quad (7)$$

whence

$$B_1 = (P/2\pi)^2 [\lambda x^2 - Th_1 (1 - h_1/\ell) + Wh_2] \quad (8)$$

where B_1 is the moment of inertia of the aircraft and rig, P the period of oscillations, λ the spring rate, x the spring moment arm about the knife-edges, h_1 and h_2 the distances of the free end of the suspension and the c.g. of the combination below the pitching axis, l the distance between the fixed and free ends of the suspension. W the total moving weight, T the total initial spring tension and ϕ the displacement angle. P was determined using a calibrated stop watch to measure the time for 50 oscillations. The spring rate was measured as described in Section 2.2, while T was calculated from the weight of the aircraft and rig and the geometry of the system; h_1 and h_2 were derived from measurements taken on the rig, the previously determined position of the aircraft c.g. and the computed position of the rig c.g. W comprised the sum of the weights of the aircraft, the lower crossbeam and knife-edge assemblies of Fig.4 and $1/3$ of the weight of the tension springs.

The moment of inertia of the test rig, an axis transfer term, and the inertia of the air moving with the aircraft must be subtracted from the results for B_1 to give the structural moment of inertia of the aircraft about its centre of gravity, B_0 .

The similarity of equations (8) and (4) may be noted.

2.4 Moment of inertia in yaw

As stated in Section 1, a three wire torsional pendulum technique was adopted. The test rig is shown in Figs.8 and 15 and consisted of a rigid gantry, built from heavy steel sections, large enough to span the aircraft. On the top of the gantry a horizontal 'A' frame was mounted, hinged to the gantry at the base of the A while the apex could be moved vertically by a screwjack. Two suspension wires were attached to the base of the 'A' and the third at a point near the apex. The latter could be moved longitudinally and locked in the desired position.

The lower ends of the two rear cables were attached to the ends of the arms of a Y beam fabricated from heavy steel sections. The third cable was attached to a point on the upright of the Y which could be moved longitudinally and locked.

Although steel wire cables were originally used for the suspension members it was suspected that twist in the cables could produce unwanted torque. They were therefore replaced by steel tubes attached to the A frame and Y beam by universal joints which had adequate freedom to rotate about two axes at right angles to the tubes. The tubes were attached to the universal joints through thrust ball races and were free to rotate through 360° about their axes.

At its forward end the Y beam was attached to the aircraft by a fork and bolt to an eyebolt at the aircraft forward slinging point on the upper fuselage, just aft of the cockpit. The two rear ends of the Y beam were joined by links to angle brackets bolted to each wing upper surface above the undercarriage legs. These links were free to rotate about lateral axes where they were attached to the Y beam and aircraft so as to accommodate longitudinal dimensional differences between the aircraft and beam resulting from manufacturing tolerances and distortion of aircraft and beam. The system was designed so that, in the undistorted state, the Y beam would be parallel to the fuselage datum line.

By arranging the suspension tubes to be of equal length, vertical, and at equal radii from the c.g. of the aircraft and Y beam combination, pitching and rolling motions were suppressed. At pitch attitudes other than zero the lower end of the front suspension tube was not at the same height above the combined c.g. as the lower ends of the two rear tubes. When the system was disturbed, this caused asymmetric loading in the rear tubes, and resulting in small residual lateral and longitudinal forces. However, the maximum values of these were calculated to be 0.002 lb and 0.1 lb respectively and were not considered to be significant.

Because the c.g. of the combination was below the plane containing the lower ends of the suspension, changing the aircraft attitude by raising or lowering the apex of the A frame also changed the radii of the tubes about the c.g. and it was therefore necessary to move the forward suspension. While it was possible to compute the required movement for each incidence, this movement itself gave rise to a small incidence change. To avoid a process of iteration, small differences between the radii of the front and rear suspensions were accepted provided that the suspension tubes were all vertical; a theodolite was used to confirm this.

The equation of motion of the system is (see Appendix C).

$$-C_1 \ddot{\beta} = W\beta \left[\frac{(x_2 r_1^2 + r_1 r_2^2)}{(x_2 + r_1)} \ell \right] \quad (9)$$

where C_1 is the yawing moment of inertia of the system, ℓ the length of the suspension, r_1 and r_2 the radial distances from the c.g. of the front and rear suspension tubes respectively, x_2 is the longitudinal horizontal distance of the rear suspension from the c.g., W the effective weight of the moving system and β the angular displacement. If P is the period of oscillation, this may be solved to give

$$C_1 = (P/2\pi)^2 \left[\frac{(x_2 r_1^2 + r_1 r_2^2)}{(x_2 + r_1)} \right] W/\ell \quad (10)$$

If r_1 and r_2 are equal this reduces to the standard equation for a multifilar torsional pendulum.

From the result thus obtained must be subtracted the moment of inertia of the moving part of the rig, the virtual inertia of the air moving with the aircraft, and the appropriate axis transfer terms.

The process was repeated for various angles of pitch attitudes and the results plotted as a function of incidence to obtain the principal moment of inertia C_0 and the inclination of the principal axis ϵ_0 .

2.5 Aerodynamic or virtual inertia

To obtain the structural moment of inertia, the moment of inertia of the air moving with the aircraft must be subtracted from the experimentally derived values.

From consideration of aircraft geometry it was concluded that the greatest value of the virtual inertia would be in the pitching case, and to obtain a value for this a one sixteenth scale flat plate model of the correct planform and c.g. position was allowed to oscillate in pitch in an altitude test cell. By comparing the periods of oscillation at densities equivalent to sea level and 100 000 ft (relative density 0.014) the aerodynamic inertia was deduced. It was found to be equivalent to 784 slug-ft² full scale, about an axis through the aircraft c.g.

The available information on the prediction of virtual inertia^{5,6} is related to aircraft having high aspect ratio wings with moderate taper and no sweep. However, the taper factor used in Refs. 5 and 6 was the ratio of the pitching inertia of a lamina of the desired plan form about its centroid to that of a rectangular lamina of the same span, area, and aspect ratio.

Using the same method with a taper factor appropriate to the HP115 plate model planform, the virtual inertia was calculated to be equivalent to 807 slug-ft² full scale about an axis through the c.g. It was therefore concluded that the method was acceptable where ground proximity was not likely to be significant. In order to be able to compare the test results with estimated values, the method was used to calculate the aerodynamic inertia about the three experimental axes. It was accepted that ground effect would probably introduce significant errors and that the calculations would establish orders of magnitude rather than precise values for the aerodynamic inertias.

3 RESULTS

3.1 Aircraft c.g. position

Measurements made previously, prior to the initial flight test programme⁷, had shown that the mid c.g. position (15 in aft of datum) could be achieved with 21 lb ballast in the forward position, and the flight tests were carried out in this condition. The weight, c.g. position, and moments of inertia were determined, therefore, with this ballast, and with a dummy pilot weighing 182 lb strapped in the cockpit.

Measurements were taken as described in Section 2.1 over a range of pitch attitude of the fuselage datum from -7° to 15° with fuel tanks full and empty. The results are plotted in Fig.9 and the values obtained for the c.g. co-ordinates, \hat{x} and \hat{z} were subsequently corrected for the undercarriage oleo extension. (The HP115 has a non-retracting undercarriage.) This correction lowered the c.g. by approximately 0.2 in but made negligible difference to the longitudinal position. The corrected values are given in Table 1 and are referred to axes parallel and normal to the fuselage datum line, with their origin at the datum point, as defined in Section 2.1. The firm's estimates⁸ for the weights and c.g. positions, with pilot, were modified to take account of the 21 lb of ballast in the nose, and also of the 10 lb of modifications and equipment added after the estimates were made. These modified estimates are also given in Table 1. Comparison of the results show that the measured c.g. positions were between 1.44 and 2.04 in (according to fuel load) forward of the estimated positions. The measured vertical positions of the c.g. were between 0.11 in and 0.45 in above the estimated positions. The measured weight with no fuel was 34 lb greater than the estimate, and that with full fuel, was 22 lb greater than the estimate. These differences are discussed in Section 4.

3.2 Moment of inertia in roll

Measurements of oscillation period and rig dimensions were taken as described in Section 2.2 over a range of pitch attitude, of the fuselage datum line, from $1^{\circ} 30'$ nose down to 10° nose up.

During the tests it was observed that a yawing motion was taking place about a vertical axis through the aft end of the rolling cradle. The amplitude of yaw increased with pitch attitude and was ascribed to the low lateral stiffness of the upper member of the cradle. The only restraint on the yawing motion was that provided by the screwjack between the forward ends of the two cradle members, and this restraint, became less effective as the jack extension increased.

The amplitude of the yawing motion was considerably reduced, but not eliminated, by joining the upper and lower cradle members at their forward ends. This bracing had to be repositioned at each change of pitch attitude. To account for the residual motion, the system was treated as having two degrees of freedom and a correction to the observed frequency deduced. This correction was then used to obtain a revised value for the roll moment of inertia. The aerodynamic inertia was calculated to be 151 slug-ft² about the experimental roll axis at a pitch attitude of 4°. The variation with pitch attitude was negligible.

The results are given in Table 2 and show the moment of inertia in roll for the aircraft about a horizontal axis through the aircraft c.g. at various angles of pitch attitude. Corrections for the yawing motion are included and are seen to be small. The results are plotted against pitch attitude in Fig.10, from which the principal moment of inertia and principal axis inclination were determined.

To obtain a more precise value for the inclination of the principal inertia axis, ϵ_0 , several values of ϵ were selected and used in the relation

$$A = A_0 + (C_0 - A_0) \cdot \sin^2 (\epsilon - \alpha) \quad (6)$$

as described in Section 2.2, and a series of graphs plotted of A as a function of $\sin^2 (\epsilon - \alpha)$, as in Figs.11 and 12, until for a particular value of ϵ the values of A were disposed about a single straight line. In this case, $\epsilon = \epsilon_0$. The values for the principal structural moments of inertia derived from Fig.10 were then corrected to give values appropriate to the aircraft weights measured in the determination of the c.g. position - Section 3.1. These corrected values are quoted in Table 1 together with estimates of the possible experimental errors and are repeated below for convenience.

Aircraft weight	lb	3906	5070
Principal axis inclination	deg	4.0°	3.9°
Moment of inertia	slug-ft ²	1195	1357
Experimental error	slug-ft ²	66	85
Aerodynamic inertia error	slug-ft ²	15	15

From the slopes of the curves shown in Fig.11 and 12, C_0 was derived, and it was here that the corrections for the yawing motion were significant.

Table 2 shows that the yaw corrections were greatest at the ends of the attitude range, i.e. at the larger values of $\sin^2 (\epsilon - \alpha)$. Thus if the corrections had been neglected in Figs. 11 and 12 the values of A_0 would not have been significantly different but the slope would have been increased to give higher values of C_0 . The values of C_0 derived from Figs. 11 and 12 were 17700 slug-ft², tanks empty, and 17806 slug-ft², tanks full.

These compare reasonably well with the results derived independently for C_0 of 17064 slug-ft² and 17368 slug-ft² (see Section 3.4) when it is considered that the former values were determined from the slope of a graph.

To establish orders of magnitude, it may be noted that the corrections to roll inertia due to yawing motion of the rig were of the order of 10 slug-ft² for a ratio of roll to yaw angular amplitudes of approximately 1000:1.

The results are discussed further in Section 4.

3.3 Moment of inertia in pitch

Measurements were taken as described in Section 2.3 but in addition the effective stiffness of the steel channels, to which the tension springs were attached, was also determined. The combined spring rate for the springs and two steel channels was found to be approximately 10% less than for the tension springs alone. If the channel members had been assumed to be rigid, the pitching moments of inertia would have been in error by nearly 15%.

The aerodynamic inertia about the experimental pitching axis was calculated to be 613 slug-ft² using the method of Ref. 5.

The values for the structural moment of inertia are given in Table 3. The corrections required by differences in aircraft weights from those measured in the determination of the c.g. position were found to be negligible, and the same values for the moments of inertia are therefore quoted in Table 1 and are repeated below.

Aircraft weight	lb	3910	5065
Moment of inertia	slug-ft ²	15519	15529
Experimental error	slug-ft ²	338	350
Moment of inertia error	slug-ft ²	61	61

These results are discussed further in Section 4.

3.4 Moment of inertia in yaw

While the links attaching the Y beam to the aircraft were vertically below the rear suspension tubes, the forward end of the Y beam was attached to the aircraft some 8 ft ahead of the front suspension tube. As a result the Y beam was distorted in the vertical plane, thus increasing the effective distance of the c.g. of the aircraft-beam combination below the suspension lower ends. In addition the aircraft itself was distorted in the vertical plane, but since it was suspended from the Y beam at points vertically above the undercarriage legs it was assumed that the aircraft distortion was the same as when resting on its undercarriage and thus that the vertical co-ordinate of the aircraft c.g. was the same as that determined in Section 3.1.

The deflected shape of the Y beam was determined by theodolite and it was found that the c.g. of the aircraft beam combination was approximately 0.25 in below the position it would have occupied with a rigid Y beam. This correction was included in the subsequent analysis.

Measurements were taken as described in Section 2.4 at various angles of pitch attitude with tanks full and empty. Care was taken in displacing the system from the equilibrium position to ensure that only yawing motion was excited. As a check, a plumb bob was suspended from a point vertically below the c.g. of the combination and when significant motion of the bob occurred the results were discarded.

The moment of inertia of the suspension system, comprising the suspension tubes, universal joints, attachment links and Y beam was determined experimentally in a similar fashion and found to be 535 slug-ft². The computed value was 558 slug-ft² and the discrepancy can be accounted for in the simplifying assumptions made in the computation, together with departures from nominal specification of the plate and steel sections from which the beam was fabricated.

The aerodynamic inertia was calculated to be 303 slug-ft² using the method of Ref.5.

The results are summarized in Table 4.

The lateral deflection of the upper end of the tower from which the aircraft was suspended was measured with the rig in motion. This was found to be less than ±0.001 in in a height of 20 ft, and it was concluded that no correction for this was necessary.

To obtain the principal moment of inertia, the values of the structural inertia obtained were plotted as a function of pitch attitude in Fig.13.

While it should be possible to determine the value of ϵ_0 from the relation

$$C = C_0 - (C_0 - A_0) \sin^2 (\epsilon_0 - \alpha) \quad (11)$$

using the same technique as for the roll inertia, the range of α available gave only a small percentage variation in C (approximately 3% compared with 15% variation in the roll case) and it did not appear likely that ϵ_0 would be obtained with the same precision as from the roll case.

The value for the principal structural moments of inertia and the inclination of the principal axis were determined from Fig.13 and are given below, together with estimates of the experimental error.

Aircraft weight	lb	3920	5058
Inclination of principal axis	deg	3.9°	3.5°
Moment of inertia C_0	slug-ft ²	17064	17368
Experimental error	slug-ft ²	188	185
Aerodynamic inertia error	slug-ft ²	30	30

The corrections due to differences between the weights of the aircraft in the test rig and the weights measured during the determination of the c.g. position were found to be negligible and the results as above are therefore quoted in Table 1.

4 DISCUSSION OF ESTIMATED AND EXPERIMENTAL VALUES

4.1 Aircraft weight and c.g. position

There was some variation in the measured weights of the aircraft between each set of tests and this may have been due to differences in residual fuel in the tanks, to the tanks not being completely filled, or to errors in weighbridge readings. In Table 1 the values for the moments of inertia have been adjusted to correspond with the weights with tanks empty and tanks full, as measured during the determination of the position of the centre of gravity. These latter weights were the minimum and maximum measured throughout the whole series of tests, and the difference between them is equivalent to the nominal capacity of the fuel tanks.

Table 1 contains the experimental results (adjusted for weight as explained above) after deduction of the estimated aerodynamic inertia. Table 1 also gives the pre-flight estimates for the aircraft for the same ballast

conditions adjusted to allow for the effects of equipment and modifications known to have been added after the estimates were made. These additions increased the weight by 10 lb, moved the c.g. forward by 0.47 in with no fuel and by 0.37 in with full fuel. There was no significant increase in the roll moment of inertia but the pitch and yaw inertias were both increased by 72 slug-ft².

Comparing the estimated and experimental values in Table 1, the measured weight of the aircraft was 34 lb greater than the estimate with tanks empty and 22 lb greater with tanks full. These are extremely small differences, being less than 1%, and may be compared with the estimated possible error in measurement of ± 10 lb.

The vertical position of the centre of gravity was higher than the estimated position by 0.11 in with tanks empty and by 0.45 in with tanks full. These differences may be compared with the estimated possible error in the measurements, which was ± 0.3 in in each case. The measured longitudinal position of the c.g. was forward of the estimated position by 2.04 in with no fuel and by 1.44 in with full fuel while the estimated experimental error was only ± 0.06 in.

The change in c.g. position due to adding fuel to the experimental values with no fuel was therefore computed and the horizontal movement was found to be 0.63 in while the measured change was 0.77 in. However the difference between these two figures, 0.14 in, is close to the sum of the experimental errors which were estimated to be ± 0.06 in for both tanks full and tanks empty cases.

No comparison was possible with the firms estimate for the longitudinal change since the distance between the aircraft e.g. with no fuel and the c.g. of the fuel was not the same as in the experimental result.

The computed vertical change of c.g. position was 0.48 in while the measured change was 0.07 in and the firms estimate was 0.41 in. The experimental error in vertical c.g. position was estimated to be ± 0.3 in for both tanks full and tanks empty cases so that the measured vertical positions of the c.g. are compatible with these errors.

Although the differences between the estimated and measured longitudinal c.g. positions seem numerically large, they could be accounted for by relatively small changes in the weight distribution. For example, transferring 15 lb from the rear of the fuselage to the nose, or adding approximately 30 lb at the fuselage nose, would each bring the estimated and measured c.g. positions into coincidence. It is doubtful if the weight estimates could be guaranteed to this order of accuracy in any case.

4.2 Moments of inertia of the fuel

The assumptions made by the firm in computing the fuel moments of inertia were not known, although it was believed that the fuel was treated as a solid body. Independent estimates were therefore made, first assuming that the fuel behaved as a solid body, and then assuming that the fuel in each tank did not rotate about the centroid of the tank as the tank rotated about the aircraft c.g.

These calculated values, and the firms estimates, were in slug-ft².

Case	Assumption	Fuel moment of inertia slug-ft ²		
		Roll	Pitch	Yaw
1	Firms estimate	212	24	216
2	Solid body	234	20	218
3	Irrotational liquid	202	2	184
4	Mean of (2) and (3)	218	11	201

The mean values, Case 4, are used in the subsequent sections, and these are not significantly different from the estimates made by the manufacturer.

4.3 Moment of inertia in roll

The experimental values, after subtraction of the computed aerodynamic inertia, were less than the estimated values by 24 slug-ft² (2%) with no fuel and by 74 slug-ft² (5.2%) with full fuel. The total estimated errors (i.e. including an arbitrary 10% error in aerodynamic inertia) were ±81 slug-ft² and ±100 slug-ft² respectively. The change in moment of inertia between tanks empty and tanks full was found to be 162 slug-ft², or 56 slug-ft² less than calculated figure given as Case 4 in Section 4.2. However, reference to Table 6 shows that the possible error in determining the vertical position of the aircraft c.g. could result in a discrepancy of this order.

As the measured weights were slightly greater than the estimated values, it was expected that the moments of inertia would also be greater than the estimates. It is possible that the aerodynamic inertia was overestimated, since the method used made no allowance for ground effect. This could have been significant, since in the test conditions the motion of the wing was normal to the ground, which was about one quarter of the mean chord below the aircraft wing. If the aerodynamic inertia was overestimated, then the structural moments of inertia derived from the experimental data would be too low.

If ground effect caused a reduction of 30% in the aerodynamic inertia compared with the free air condition, then the experimental values of the moment of inertia would be slightly greater than the manufacturers estimate with no fuel, and slightly less with full fuel.

4.4 Moment of inertia in pitch

The experimental values, after subtraction of the computed aerodynamic inertia, were lower than the estimates by 178 slug-ft² (1.1%) with no fuel and by 192 slug-ft² (1.2%) with full fuel. The total estimated errors, including an arbitrary 10% error in aerodynamic inertia, were ±400 slug-ft² and ±411 slug-ft² respectively. The change in moment of inertia due to fuel was found to be 10 slug-ft² while the estimated change, Case 4 of the table in Section 4.2, was 11 slug-ft². The firms estimate for the fuel contribution was 24 slug-ft².

As in the roll case, it was expected that the moments of inertia would be slightly greater than the manufacturers estimates because of weight differences and a similar argument that the aerodynamic inertia was overestimated due to neglecting ground effect can be advanced. If a 30% reduction in aerodynamic inertia due to ground effect is assumed, then the differences between the experimental results and the pre-flight estimates would be negligible.

4.5 Moment of inertia in yaw

The experimental values for the structural moments of inertia were in this case greater than the manufacturers estimates by 278 slug-ft² (1.7%) with no fuel and by 366 slug-ft² (2.1%) with full fuel. The corresponding total estimated errors, again assuming an arbitrary 10% error in aerodynamic inertia, were ±218 slug-ft² and ±215 slug-ft².

The change due to fuel was found to be 304 slug-ft², while the computed value was only 201 slug-ft². Reference to Table 6 shows that this discrepancy could be accounted for by the possible errors in measuring the period of oscillation.

The effects of ground proximity on the aerodynamic inertia was probably much less in the yaw case than in the other two since the aircraft motion was parallel to the ground, which could therefore be expected to have less influence on the volume of air moving with the aircraft.

4.6 $A_o + B - C_o$

For a solid body, the sum of the moments of inertia about two orthogonal axes through its centre of gravity must be greater than the moment of inertia about a third axis perpendicular to the first two. For aircraft, whose vertical

dimensions are much less than their longitudinal and lateral dimensions, the sum of the moments of inertia in roll and pitch is usually only slightly greater than the moment of inertia in yaw. From the firms estimates, $A_0 + B - C_0 = 130 \text{ slug-ft}^2$ with tanks empty and 150 slug-ft^2 with tanks full. From the test results, after subtraction of the aerodynamic inertia to give the results in Table 1, $A_0 + B - C_0 = -350 \text{ slug-ft}^2$ with no fuel and -482 slug-ft^2 with full fuel. The experimental errors in this summation are 592 slug-ft^2 (no fuel) and 620 slug-ft^2 (full fuel) both assuming no error in aerodynamic inertia. If a 10% error in the latter about each axis is assumed, then the errors become 698 slug-ft^2 and 726 slug-ft^2 . Thus although $A_0 + B - C_0$ is negative in both tanks empty and tanks full cases, the possible experimental errors are sufficient to make the sum positive even if no account is taken of errors in aerodynamic inertia.

4.7 Inclination of principal inertia axis

The inclination of the principal axis was determined from both the roll and yaw tests. From the roll tests the values obtained were 4° and 3.9° with tanks empty and full respectively, while from the yaw results the corresponding values were 3.9° and 3.5° . In the roll tests the range of pitch attitude available was from $-1^\circ 30'$ to $+10^\circ$, giving a variation in measured moment of inertia of 14%. In yaw the range of attitude available was from 0° to 8° but the moment of inertia variation was only 3% of C_0 . Since ϵ_0 was determined graphically, the values of ϵ_0 obtained from the roll tests were considered to be the more reliable, and are quoted in Table 1.

They differ from the estimates by 1.1° and it is worth noting that apparent differences between flight and wind tunnel values in the derivatives l_v and n_v were considerably reduced when the measured values for ϵ_0 were substituted for estimated values in the analysis of flight test results.

5 MOMENTS OF INERTIA FOR FLIGHT TESTS ANALYSIS

The moments of inertia for use in the analysis of flight test results should comprise the moments of inertia of the aircraft in vacuo and the aerodynamic inertia appropriate to the test altitude.

However, because of doubts in applying the method for calculating virtual inertia to the experimental conditions, as discussed in Section 4, it did not appear that subtracting the sea level aerodynamic inertia from the experimental moments of inertia and then adding the aerodynamic inertia for the test attitude would significantly increase the accuracy of results derived from the flight tests.

In support of this, it is suggested in Section 4 that the calculated aerodynamic inertia in pitch and roll may have been as much as 30% greater than that actually present in the experimental conditions. This change is approximately the same as the reduction in virtual inertia at 10000 ft (the maximum test altitude) from the sea level value, that is, 26%.

The moments of inertia used for flight test analysis were therefore taken as the experimental values before the subtraction of the calculated aerodynamic inertia.

These were, for fuel tanks empty, 1346 slug-ft² in roll, 16132 slug-ft² in pitch, and 17367 slug-ft² in yaw. The corresponding figures for full fuel were 1508 slug-ft², 16142 slug-ft² and 17671 slug-ft².

The sum $A_0 + B - C_0$ is 111 slug-ft² for no fuel and -21 slug-ft² for full fuel. However, as discussed in Section 4, it is possible that with full fuel, the measured moments of inertia were too low by 56 slug-ft² in roll and too high by 103 slug-ft² in yaw. If allowance is made for these changes, then for full fuel, $A_0 + B - C_0 = 138$ slug-ft².

The values for this summation using the firms estimated values are 130 slug-ft² with no fuel and 150 slug-ft² with full fuel.

6 CONCLUSIONS

Values derived from the experimental results for the weights, c.g. positions, principal moments of inertia and the inclination of the principal axes, together with the corresponding estimated values are given in Table 1. The moments of inertia used in analysis of flight test results are given in Table 5.

Comparison of the results in Table 1 shows that the aircraft weight was underestimated by 34 lb (0.9%) with no fuel and by 22 lb (0.4%) with full fuel. The estimated c.g. positions were too far aft by between 1.44 in and 2.04 in, according to the fuel state, but comparatively small changes in the weight distribution could account for this.

The measured changes in c.g. position due to adding fuel were consistent with calculated changes within the estimated limits of experimental error.

The experimental values of the moments of inertia in roll, after subtraction of calculated values of the aerodynamic inertia, were less than the estimated values by 2% with no fuel and by 5.2% with full fuel. These differences were both less than the experimental errors. In pitch, the experimental values after subtraction of estimated aerodynamic inertia, were lower than the

estimates by 1.1% with no fuel and by 1.2% with full fuel. These differences were also both less than the estimated experimental errors.

In yaw, the results derived from the experimental values by subtracting the calculated aerodynamic inertia were larger than the estimates by 1.7% with no fuel and by 2.1% with full fuel. These differences were slightly greater than the combined experimental and aerodynamic inertia errors of 1.3% in both tanks full and tanks empty cases.

The difference between the experimental moments of inertia with tanks full and tanks empty about each axis is compatible with the calculated moment of inertia of the fuel and the estimated experimental error about that axis.

The inclination of the principal axis relative to the fuselage datum line was found to be 4° nose down with no fuel and 3.9° with full fuel, compared with the estimated value of 5.1° in both cases. The differences between these estimated and measured values were sufficient to cause appreciable changes in stability derivatives derived from flight test analysis.

The values for the moments of inertia in yaw obtained from the roll moment of inertia derivation differed from the values derived directly by less than 4%, suggesting that the yaw inertia could be obtained to this order of accuracy by the variable attitude roll inertia technique if weight and space considerations prevent the use of a separate yaw rig.

Flexibilities in the pitch and roll rigs were significant enough to be taken into account, although in the roll rig they could probably be neglected when it is not required to obtain yaw inertia from roll tests.

The method used for calculating aerodynamic inertia needs to be revised to allow for ground effect and to include current aircraft shapes. Some tests are about to start on a model of the Fairey Delta 2 with these objectives, and similar tests for a model of the HP115 are planned.

ACKNOWLEDGEMENTS

The work described here was carried out with the valuable assistance of Mr. P.J. Haynes.

The measurement of aerodynamic inertia using a flat plate model (Section 2.5) was devised and carried out by Mr. D.R. Dennis.

Appendix AEQUATION OF MOTION IN ROLL

Referring to Fig.5 and denoting quantities to right and left of the centre line by subscripts R and L

$$\theta_L \doteq \theta_R = \vartheta ; \quad \cos \theta \doteq 1 ; \quad \sin \theta \doteq \gamma h_1 / \ell$$

$$\delta T_R = - \delta T_L = \lambda y \gamma .$$

Taking moments about the knife edge

$$\begin{aligned} -L = & y(T+\delta T) \cos \theta - (\ell-h_1) (T+\delta T) \sin \theta - y(T-\delta T) \cos \theta \\ & - (\ell-h_1) (T-\delta T) \sin \theta - Wh_2 \sin \gamma . \end{aligned} \quad (A.1)$$

To first order of small quantities, this reduces to

$$-L = y(T+\lambda y \gamma) - 2T(\ell-h_1) \gamma h_1 / \ell - y(T-\lambda y \gamma) - Wh_2 \gamma . \quad (A.2)$$

Whence

$$-L = [2\lambda y^2 - 2Th_1(1-h_1/\ell) - Wh_2] \gamma \quad (A.3)$$

and if A_1 is the moment of inertia of the rolling system

$$A_1 \ddot{\gamma} = -L .$$

Whence

$$A_1 = (P/2\pi)^2 [2\lambda y^2 - 2Th_1(1-h_1/\ell) - Wh_2] \quad (A.4)$$

where P is the period of oscillation.

Appendix B

EQUATION OF MOTION IN PITCH

Referring to Fig.6, with the system at rest

$$T x_1 - Wx_2 = 0 \quad . \quad (B.1)$$

If it is now displaced through a small angle ϕ , taking moments about the knife edge.

$$M = x_1 (T - \delta T) \cos \theta + (\ell - h_1) (T - \delta T) \sin \theta - W(x_2 + h_2 \phi) \quad . \quad (B.2)$$

To first order of small quantities.

$$\cos \theta \doteq 1, \quad \sin \theta = h_1 \phi / \ell, \quad \delta T = \lambda x_1 \phi$$

and we have

$$M = x_1 (T - \lambda x_1 \phi) + (T - \lambda x_1 \phi) (\ell - h_1) h_1 \phi / \ell - W(x_2 + h_2 \phi) \quad . \quad (B.3)$$

Substituting from (B.1) and neglecting the term in ϕ^2

$$M = [-\lambda x_1^2 + Th_1(1 - h_1/\ell) - Wh_2] \phi \quad . \quad (B.4)$$

If B_1 is the moment of inertia of the system

$$B_1 \ddot{\phi} = -M \quad .$$

Whence

$$B_1 = (P/2\pi)^2 [\lambda x_1^2 - Th_1(1 - h_1/\ell) + Wh_2] \quad (B.5)$$

where P is the period of oscillation.

Appendix C

EQUATION OF MOTION IN YAW

T_1, T_2, T_3 are the tensions in three vertical suspension tubes of length ℓ at radii r_1, r_2, r_3 from the centre of gravity of the suspended body of weight W . If the body is displaced through a small angle β about a vertical axis through its c.g. then the suspension tubes will make angles $r\beta/\ell$ to the vertical. The tangential components of the tension in the plane of rotation are $T\beta r/\ell$ and the total moment about the c.g. is

$$N = \Sigma T\beta r^2/\ell \quad . \quad (C.1)$$

Assuming a symmetric system where $r_2 = r_3$ and the projection of r_2 along r_1 is x_2 and that the variation of T with β can be neglected.

$$T_1 = Wx_2/(r_1 + x_2) \quad (C.2)$$

$$T_2 = T_3 = Wr_1/2(r_1 + x_2) \quad (C.3)$$

and

$$N = W\beta(x_2 r_1^2 + r_1 r_2^2)/(r_1 + x_2) \ell \quad . \quad (C.4)$$

If C is the moment of inertia of the system oscillating with period P

$$C = (P/2\pi)^2 W(x_2 r_1^2 + r_1 r_2^2)/(r_1 + x_2) \ell \quad . \quad (C.5)$$

Appendix DERROR ANALYSIS

The determination of the c.g. position and of the six moments of inertia involved taking a number of measurements of distance, weights, times, and spring rates. The possible error for each measurement was assessed from the scatter of repeated measurements of nominally identical values, or by comparing measured dimensions with nominal values from constructional drawings. Where no comparison was possible errors of $1/32$ " were assumed for distances and $0^{\circ} 5'$ for angles. The errors in timing were estimated from the scatter in repeated measurements of the total time for a large number of oscillations (50 cycles in roll and pitch, 20 cycles in yaw).

An arbitrary error of 10% was assumed for the aerodynamic inertia but to facilitate examination of the effects of the latter, Table 5 gives the total of the experimental errors and then the sum of the experimental and aerodynamic inertia errors. Certain of the experimental errors are random in that the error with no fuel may not be of the same sign as the error with full fuel, while others are systematic because the measurement was the same whether the tanks were full or empty, and the error in the parameter would therefore cause the consequential error to have the same sign in both cases. Examples of random errors are the oscillation period and aircraft weight, while the principal systematic errors were the spring rates and moment arms, the test rig weights, c.g. positions, and moments of inertia.

The systematic errors are denoted by an asterisk in Table 5.

Table 1

SUMMARY OF ESTIMATED AND EXPERIMENTAL VALUES

Fuel state	Units	Experimental results		Manufacturers estimates		Possible error	
		Tanks empty	Tanks full	Tanks empty	Tanks full	Tanks empty	Tanks full
Aircraft weight	lb	3906	5070	3872	5048	±10	±10
c.g. aft of datum	in	14.54	15.31	16.58	16.75	±0.06	±0.06
c.g. above datum	in	21.76	21.69	21.65	21.24	±0.30	±0.30
Principal moment of inertia - roll	slug-ft ²	1195	1357	1219	1431	±81	±100
Moment of inertia - pitch	slug-ft ²	15519	15529	15697	15721	±400	±411
Principal moment of inertia - yaw	slug-ft ²	17064	17368	16786	17002	±218	±215
Inclination of principal axis	deg.	4.0°	3.9°	5.1°	5.1°	±0.1°	±0.1°

Table 2 - MOMENT OF INERTIA IN ROLL

Aircraft weight	Pitch attitude	Moment of inertia of rig and aircraft about knife edges	Moment of inertia of rig about knife edges	Correction for yawing motion	Axis transfer for aircraft	Aerodynamic inertia	Total deductions	Moment of inertia of aircraft about horizontal axis through c.g.
lb	deg. min.	slug-ft ²	slug-ft ²	slug-ft ²	slug-ft ²	slug-ft ²	slug-ft ²	slug-ft ²
3907	-1° 30'	2315	99	6	710	151	966	1349
	0	2285	99	1	760	151	1011	1274
	2°	2288	99	0	825	151	1075	1213
	3°	2306	100	0	860	151	1111	1195
	4°	2339	101	0	890	151	1142	1197
	5°	2376	101	0	922	151	1174	1202
	5° 59'	2430	103	0	958	151	1212	1218
	8°	2569	106	8	1024	151	1289	1280
	9°	2655	107	10	1060	151	1328	1327
10° 1'	2740	108	12	1093	151	1364	1376	
5057	-1° 30'	2681	99	6	925	151	1181	1500
	0°	2671	99	1	985	151	1236	1435
	2°	2695	99	0	1068	151	1318	1377
	3°	2720	100	0	1110	151	1361	1359
	4°	2757	101	0	1150	151	1402	1355
	5°	2811	101	0	1192	151	1444	1367
	6°	2870	103	0	1237	151	1491	1379
	8°	3019	106	8	1323	151	1588	1431
	10°	3218	108	12	1401	151	1672	1546

Table 5MOMENTS OF INERTIA FOR FLIGHT TEST ANALYSIS

CONDITIONS: 21 lb ballast in nose position

182 lb pilot

Aircraft batteries in rear compartment.

Weight	lb	3906	5070
c.g. aft of datum	in	14.54	15.31
c.g. above datum	in	21.76	21.69
Moment of inertia in roll	slug-ft ²	1346	1508
Moment of inertia in pitch	slug-ft ²	16132	16142
Moment of inertia in yaw	slug-ft ²	17367	17671
Inclination of principal axis		4.0°	3.9°

Table 6

TYPICAL MEASUREMENTS AND POSSIBLE ERRORS

Quantity	Axis	Roll				Pitch				Yaw			
	Units	Nominal value	Possible error	Inertia error in slug-ft ²		Nominal value	Possible error	Inertia error in slug-ft ²		Nominal value	Possible error	Inertia error in slug-ft ²	
				Tanks empty	Tanks full			Tanks empty	Tanks full			Tanks empty	Tanks full
Oscillation period - tanks empty	sec	1.733	±0.002	±6.8		0.7585	±0.002	±110.0		6.378	±0.010	±58.4	
Oscillation period - tanks full	sec	1.986	±0.002		±6.6	0.7706	±0.002		±110.3	5.793	±0.010		±62.4
Weight of aircraft - tanks empty	lb	3907	±10.0	±2.2		3910	±10	±6.2		3920	±10	±41.8	
Weight of aircraft - tanks full	lb	5057	±10		±1.2	5065	±10		±6.0	5058	±10		±28.6
Weight of test equipment	lb	822	±5	±1.1	±0.6	148	±5	±52.0	±51.7	551	±5	±16.4	±9.6
Aircraft c.g. aft of datum, tanks empty	in	14.54	±0.06	±1.0		14.54	±0.06	±5.4		14.55	±0.06	±1.8	
Aircraft c.g. aft of datum, tanks full	in	15.31	±0.06		±0.7	15.30	±0.06		±6.7	15.30	±0.06		±1.8
Aircraft c.g. above datum, tanks empty	in	21.76	±0.30	±23.8		21.76	±0.30	±7.2		21.76	±0.30	±0.7	
Aircraft c.g. above datum, tanks full	in	21.69	±0.30		±34.0	21.69	±0.30		±8.8	21.69	±0.30		±1.8
Test equipment c.g. aft of datum	in									0.94	±0.85	±2.0	±3.4
Test equipment c.g. below datum	in	11.32	±0.65	±2.9	±3.7	13.01	±0.13	±0.2	±0.2	44.95	±0.10	±0.5	±0.5
Spring moment arm	in	56.72	±0.03	±3.3	±4.9	216.1	±0.25	±43.0	±44.1				
Spring effective length	in	55.88	±0.06	±0.7	±0.4	62.0	±0.15	0	0				
Pitch attitude	deg	4° 0'	±0° 5'	±1.9	±2.7					4° 19'	±0° 5'	±1.7	±4.0
Spring rate	lb/in	77.72	±0.39	±15.7	±21.2	354.4	±1.8	±99.8	±103.7				
Datum forward of rotation axis	in					66.62	±0.16	±14.2	±18.0	12.85	±0.07	±2.4	±1.9
Datum above rotation axis	in	11.94	±0.03	±2.8	±3.3								
Spring attachment above axis	in	14.50	±0.03	±2.1	±4.5	-22.01	±0.13	±0.2	±0.2				
Test equipment moment of inertia	slug-ft ²	102	±1.5	±1.5	±1.5	(Included in rig weight error)				532	±7.0	±7.0	±7.0
Front suspension forward of datum	in									67.88	±0.06	±5.4	±13.3
Rear suspension aft of datum	in									66.10	±0.20	±37.0	±36.3
Rear suspension - spanwise position	in									56.75	±0.06	±5.8	±4.4
Suspension length	in									133.0	±0.06	±6.9	±9.9
Experimental errors	slug-ft ²			±65.8	±85.3			±338.2	±349.7			±187.8	±184.9
Aerodynamic inertia	slug-ft ²	151		±15.1	±15.1	613		±61.3	61.3	303		±30.3	±30.3
Total error	slug-ft ²			±80.9	±100.4			±399.5	±411.0			±218.1	±215.2

° Systematic errors (see Appendix D).

SYMBOLS

<u>Symbols</u>	<u>Unit</u>	<u>Definition</u>
A, A_1	slug-ft ²	roll moments of inertia
A_0	slug-ft ²	roll moment of inertia about principal axis
B, B_1	slug-ft ²	pitch moments of inertia
C, C_1	slug-ft ²	yaw moments of inertia
C_0	slug-ft ²	yaw moment of inertia about principal axis
d_1	ft	horizontal distance from main wheels to datum
d_2	ft	horizontal distance from main wheels to nose wheel
h_1	ft	vertical distance from pitch or roll axis to moving spring attachment
h_2	ft	vertical distance of c.g. of aircraft and rig from pitch or roll axis
ℓ	ft	distance between fixed and moving spring attachments; suspension length
L, M, N	ft lb	rolling, pitching and yawing moments
P	sec	period of oscillation
R_N	lb	weight of aircraft carried by nose wheel
R_M	lb	weight of aircraft carried by main wheels
r_1, r_2	ft	radii of front and rear yaw suspensions from c.g.
T	lb	tension in spring or suspension
W	lb	weight
\hat{x}	ft	longitudinal distance of aircraft c.g. from datum
x	ft	spring arm about pitch axis
x_2	ft	yaw rig longitudinal distance from rear suspension to c.g.
y	ft	spring arm about roll axis
\hat{z}	ft	vertical distance of aircraft c.g. from datum
α	radian	pitch attitude
β	radian	angular displacement in yaw
γ	radian	angular displacement in roll
ϕ	radian	angular displacement in pitch
θ	radian	angular displacement of suspension from vertical
ϵ_0	radian	inclination of principal axis
λ	lb/ft	spring rate

REFERENCES

<u>No.</u>	<u>Author</u>	<u>Title, etc.</u>
1	W.J.G. Pinsker	The lateral motions of aircraft and in particular of inertially slender configurations. A.R.C. R & M 3334, September 1961
2	D.H. Perry	Measurements of the moments of inertia of the AVRO 707B aircraft. A.R.C.C.P. 647, August 1961
3	D. Hope	Measurement of the moment of inertia of the Buccaneer S Mk.1. Hawker Siddeley Report YMT 2623, January 1964
4	R.W. Boucher D.A. Rich H.L. Crane C.E. Matheny	A method for measuring the product of inertia and the inclination of the principal longitudinal axis of inertia of an airplane. NACA Technical Note 3084, April 1954
5	F.S. Malvestuto L.J. Gale	Formulas for additional mass corrections to the moments of inertia of airplanes. NACA Technical Note 1187, February 1947
6	W. Gracey	The additional mass effect of plates as determined by experiment. NACA Report 707,
7	P.L. Bisgood C.O. O'Leary	Interim report on low speed flight tests of a slender wing research aircraft (HP115). A.R.C. C.P. 838, November 1963
8	Handley Page Ltd.	HP115 inertia summary. HP Reference WDS 115/11, 115/13-115/18, March 1961

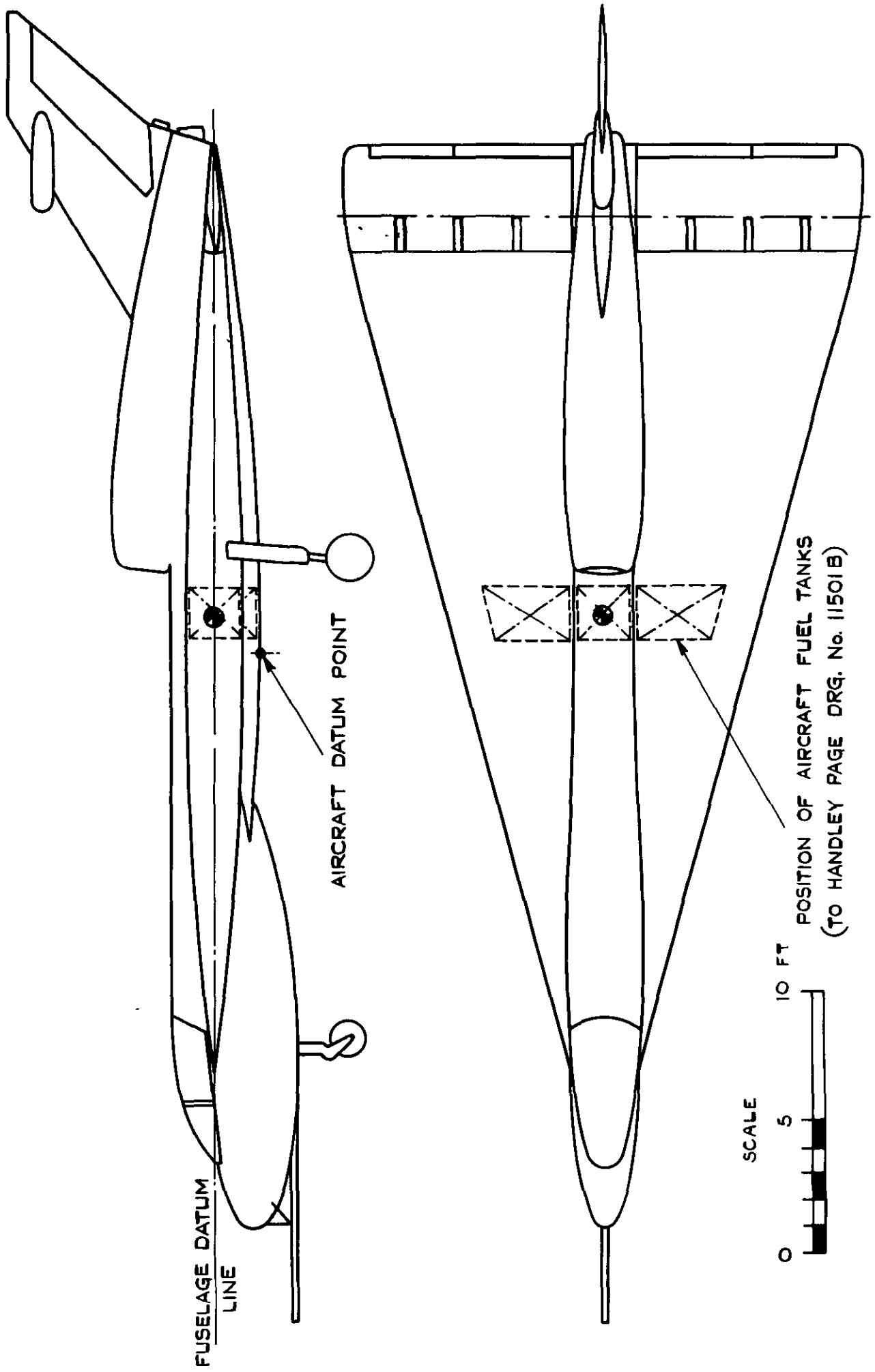
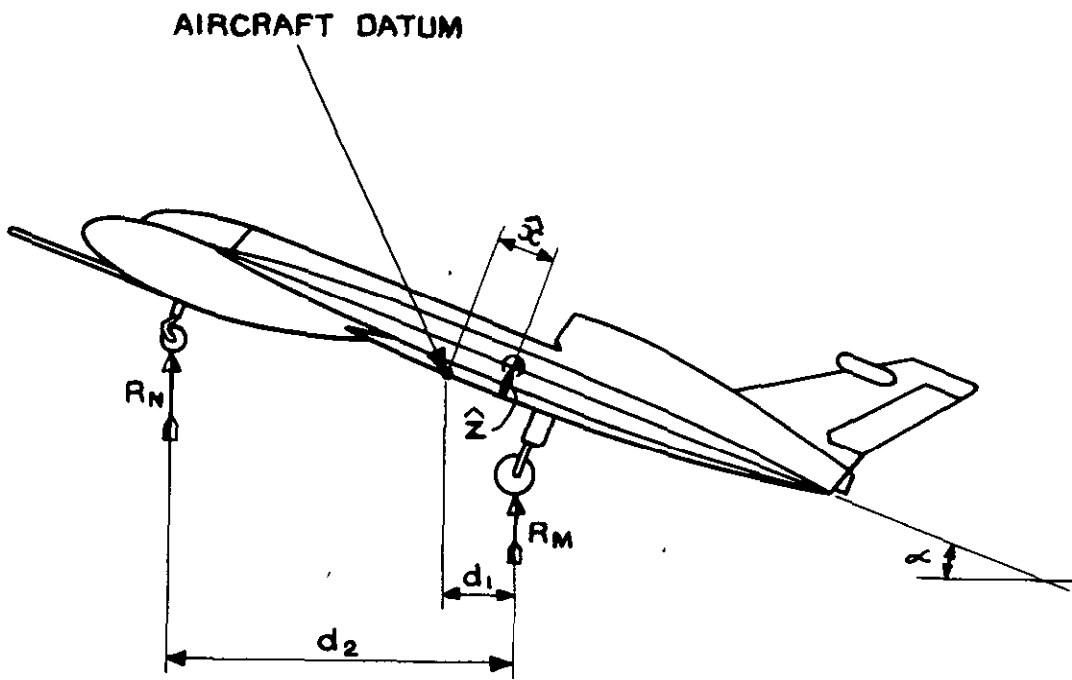
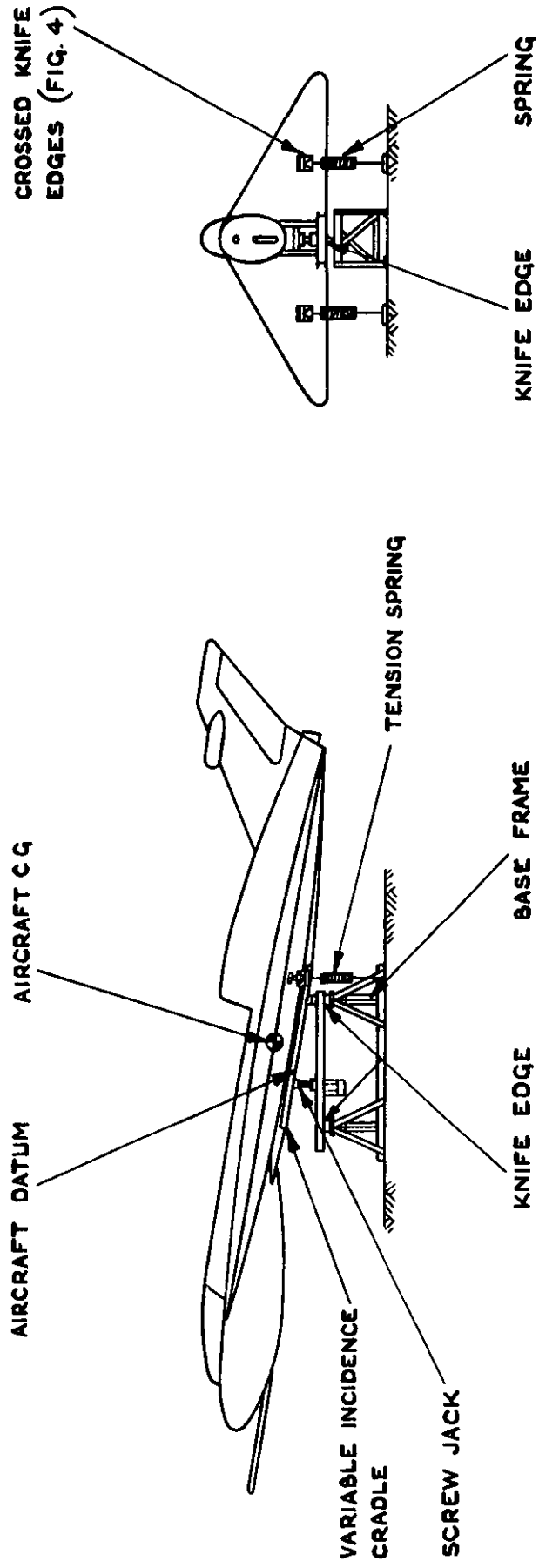

FIG. I. GENERAL ARRANGEMENT OF HANDLEY - PAGE H.P. 115.



$$(R_N + R_M) (\hat{x} \cos.\alpha + \hat{z} \sin.\alpha) + R_N (d_2 - d_1) - R_M d_1 = 0$$

FIG. 2 DETERMINATION OF AIRCRAFT C.G.



NOTE: UNDERCARRIAGE OMITTED FOR CLARITY

FIG. 3 AIRCRAFT ON ROLLING MOMENT OF INERTIA RIG.

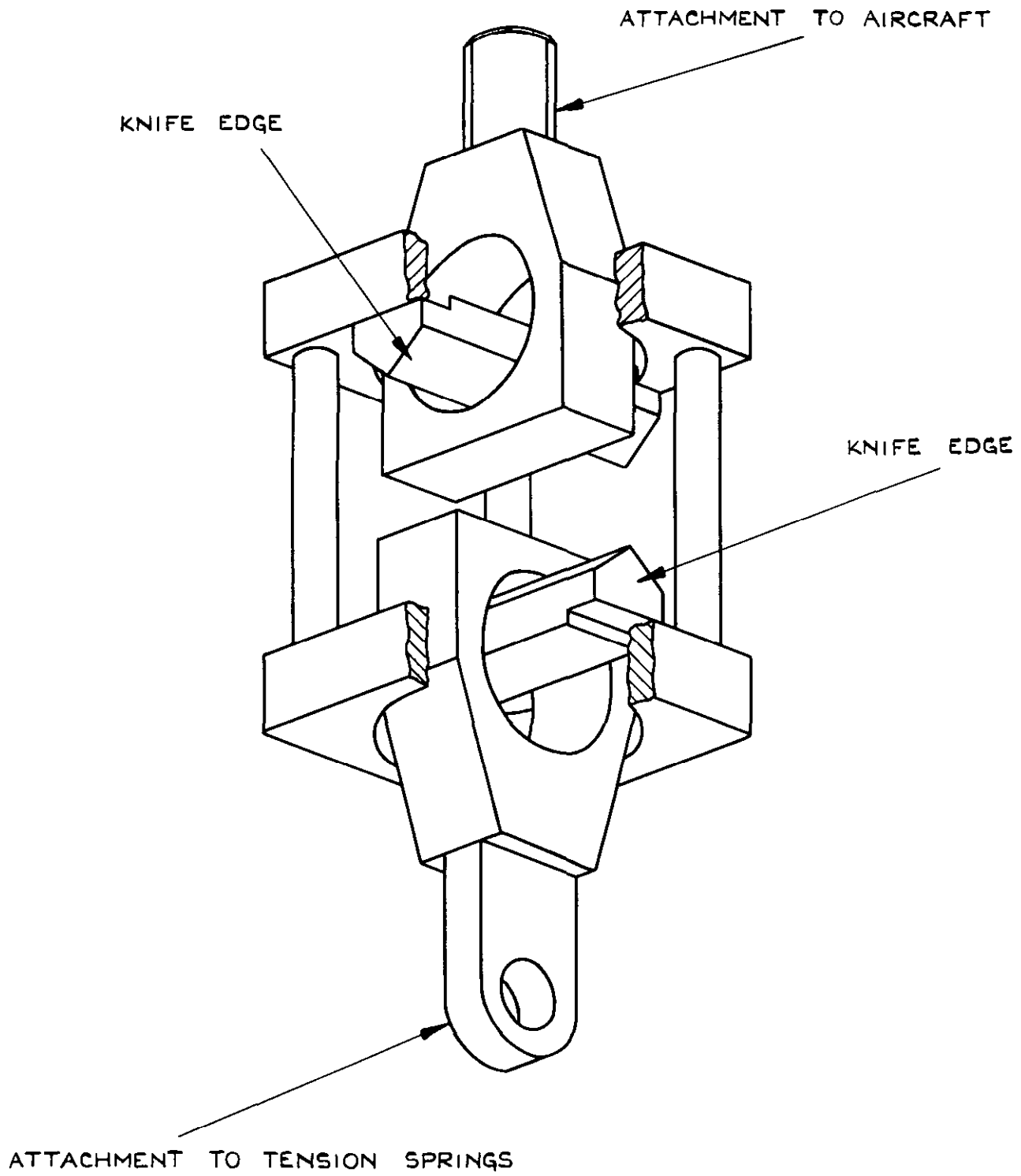
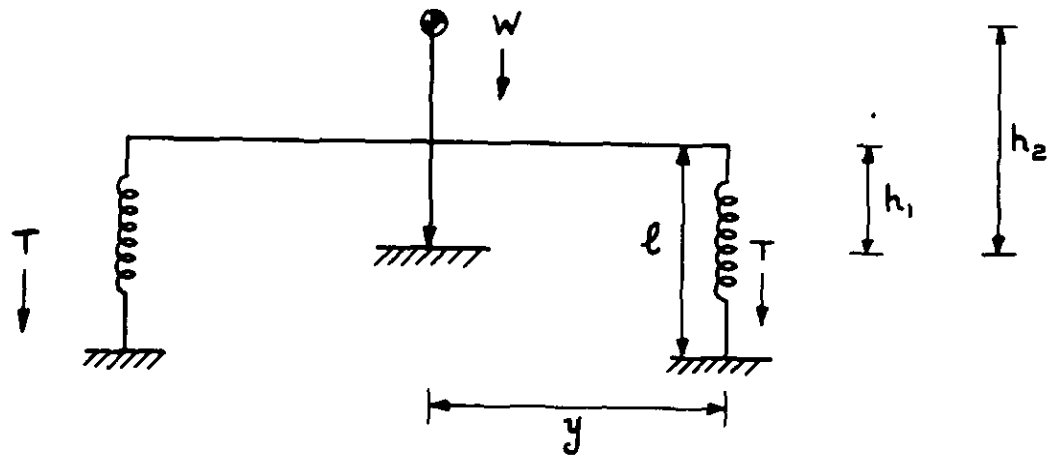
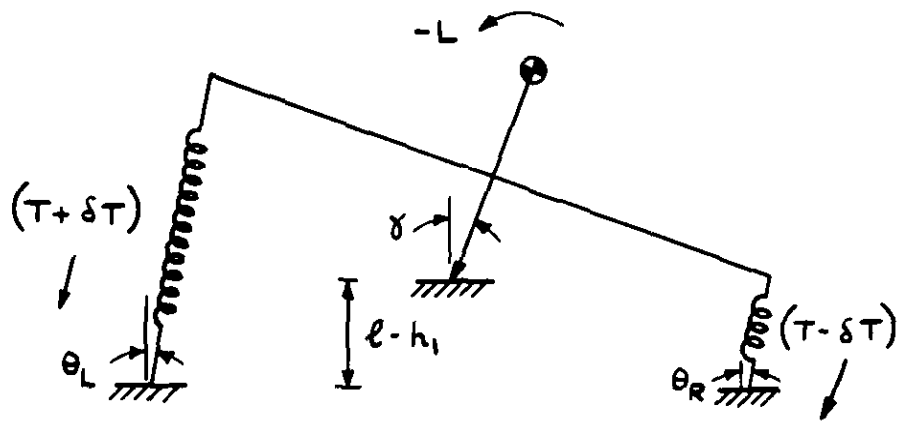

FIG.4 DIAGRAM OF CROSSED KNIFE EDGES



(a) SYSTEM IN EQUILIBRIUM



(b) SYSTEM DISPLACED

FIG.5 ROLL INERTIA RIG IN DIAGRAMMATIC FORM

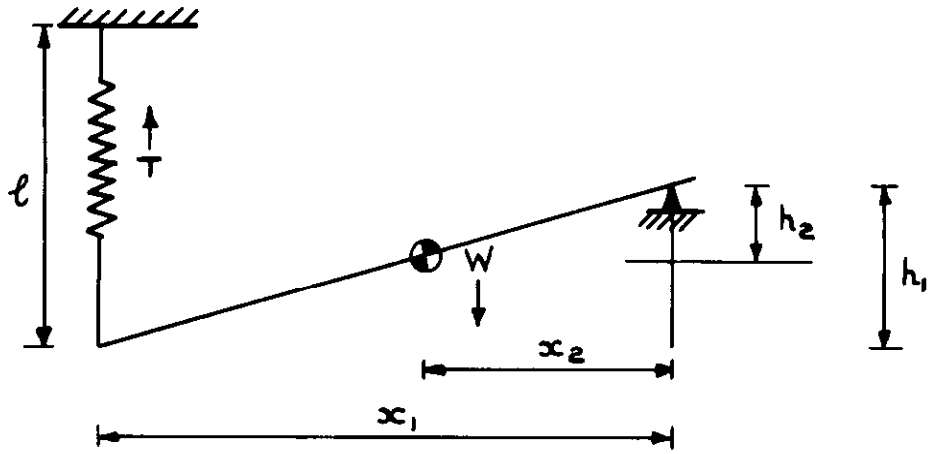

(a) SYSTEM IN EQUILIBRIUM

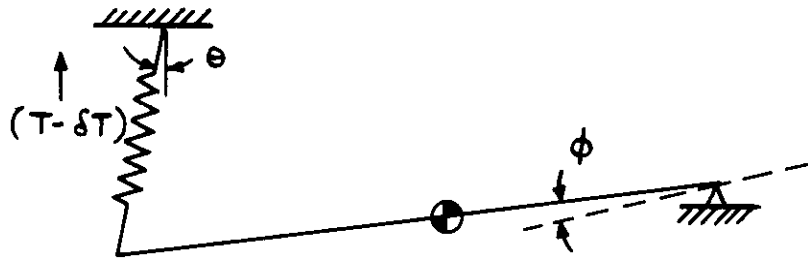

(b) SYSTEM DISPLACED

FIG. 6 PITCH INERTIA RIG IN DIAGRAMMATIC FORM

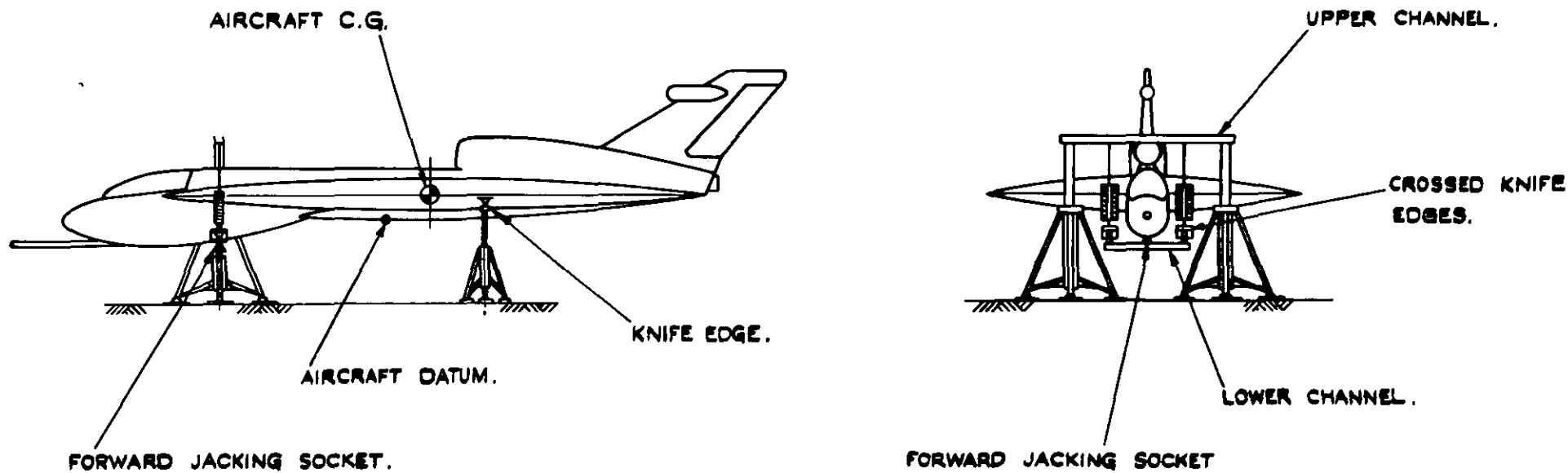

N.B. UNDERCARRIAGE AND FORWARD PORT JACK OMITTED FOR CLARITY.

FIG. 7 AIRCRAFT ON PITCHING MOMENT OF INERTIA RIG.

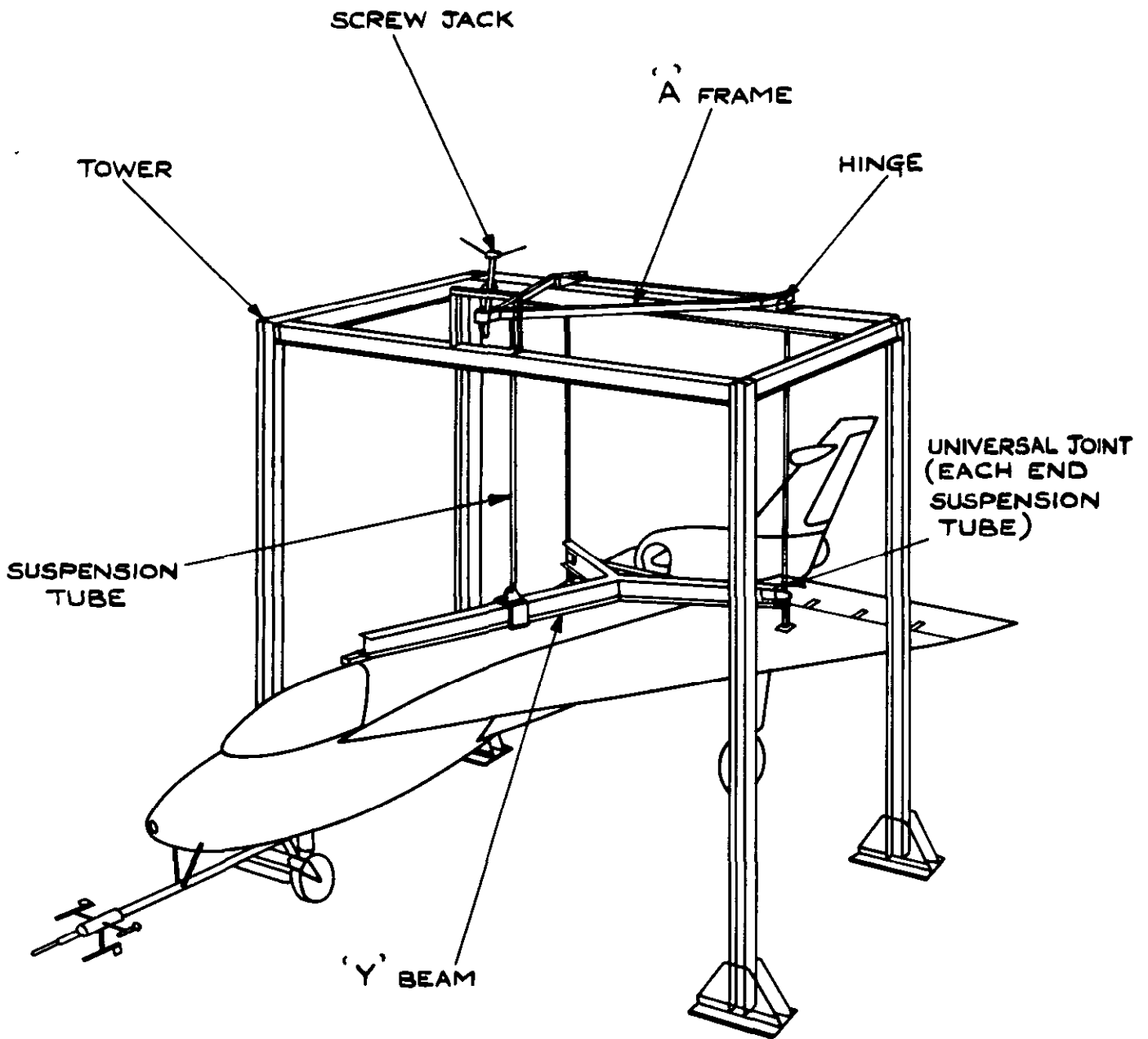

FIG.8 AIRCRAFT ON YAWING MOMENT OF INERTIA RIG

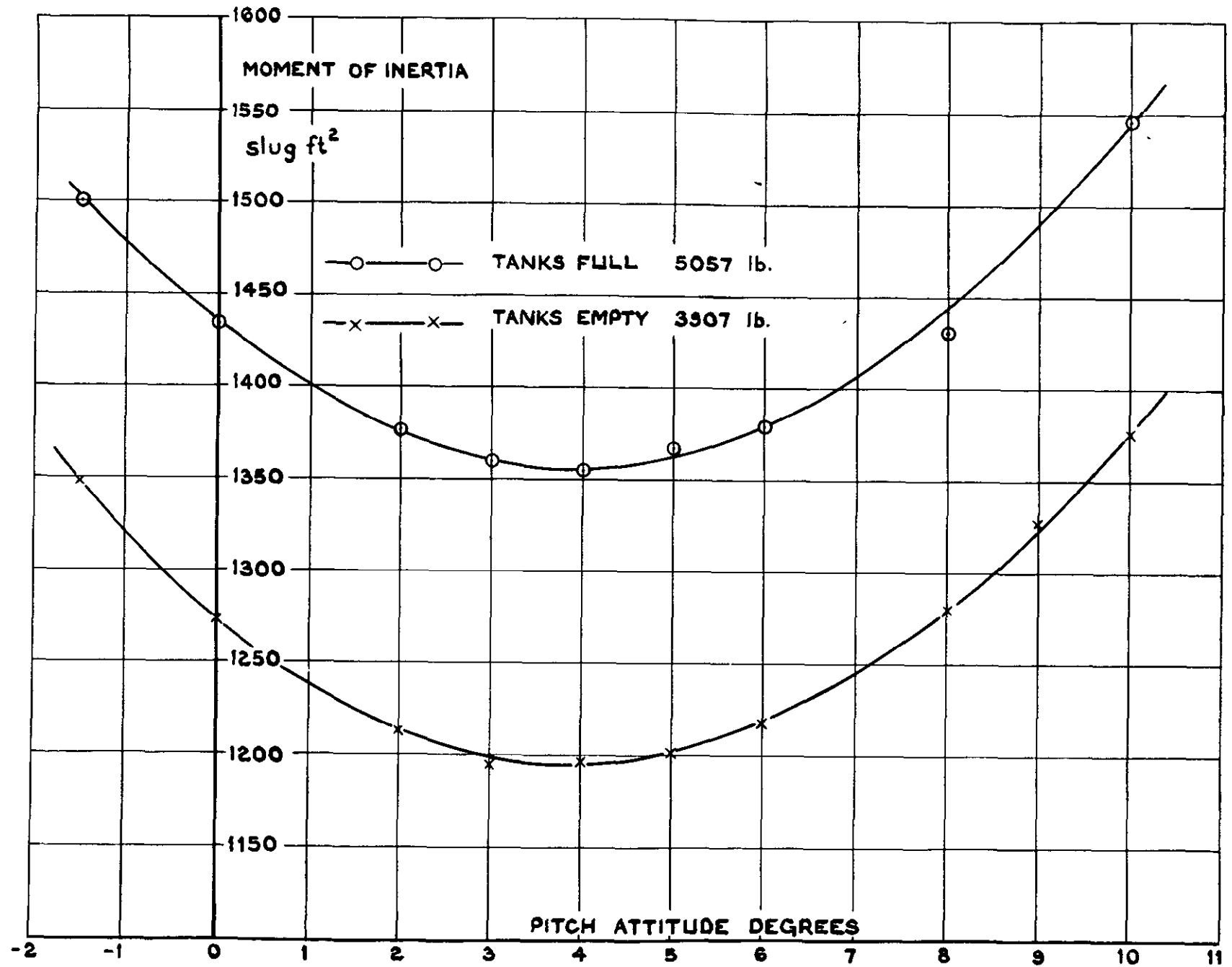

FIG. 10 VARIATION OF ROLL INERTIA WITH PITCH ATTITUDE

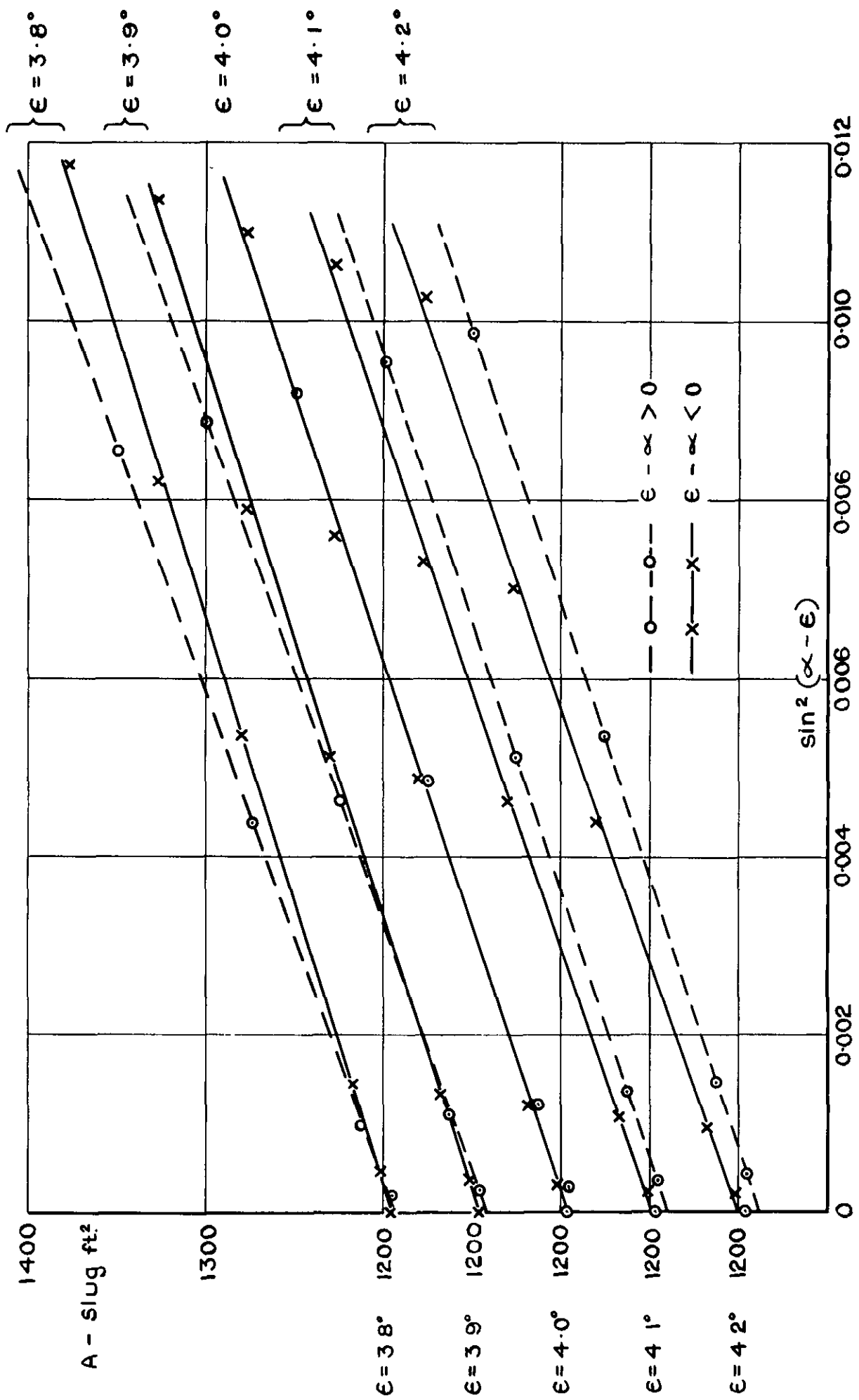

FIG. 11 DETERMINATION OF ϵ_0 FROM ROLL INERTIA MEASUREMENTS - TANKS EMPTY

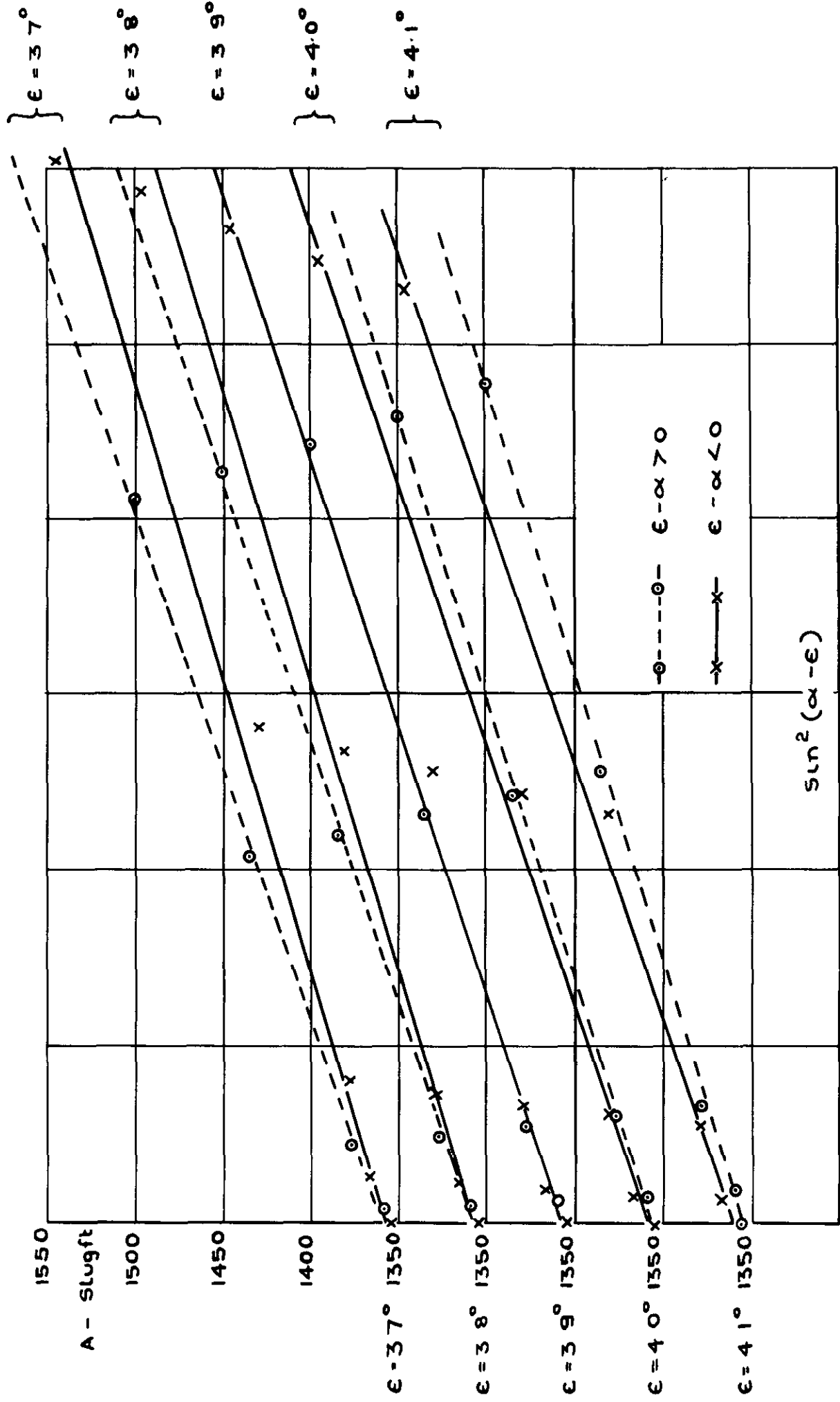

FIG.12. DETERMINATION OF ϵ_0 FROM ROLL INERTIA MEASUREMENTS-TANKS FULL.

C
SLUG ft²

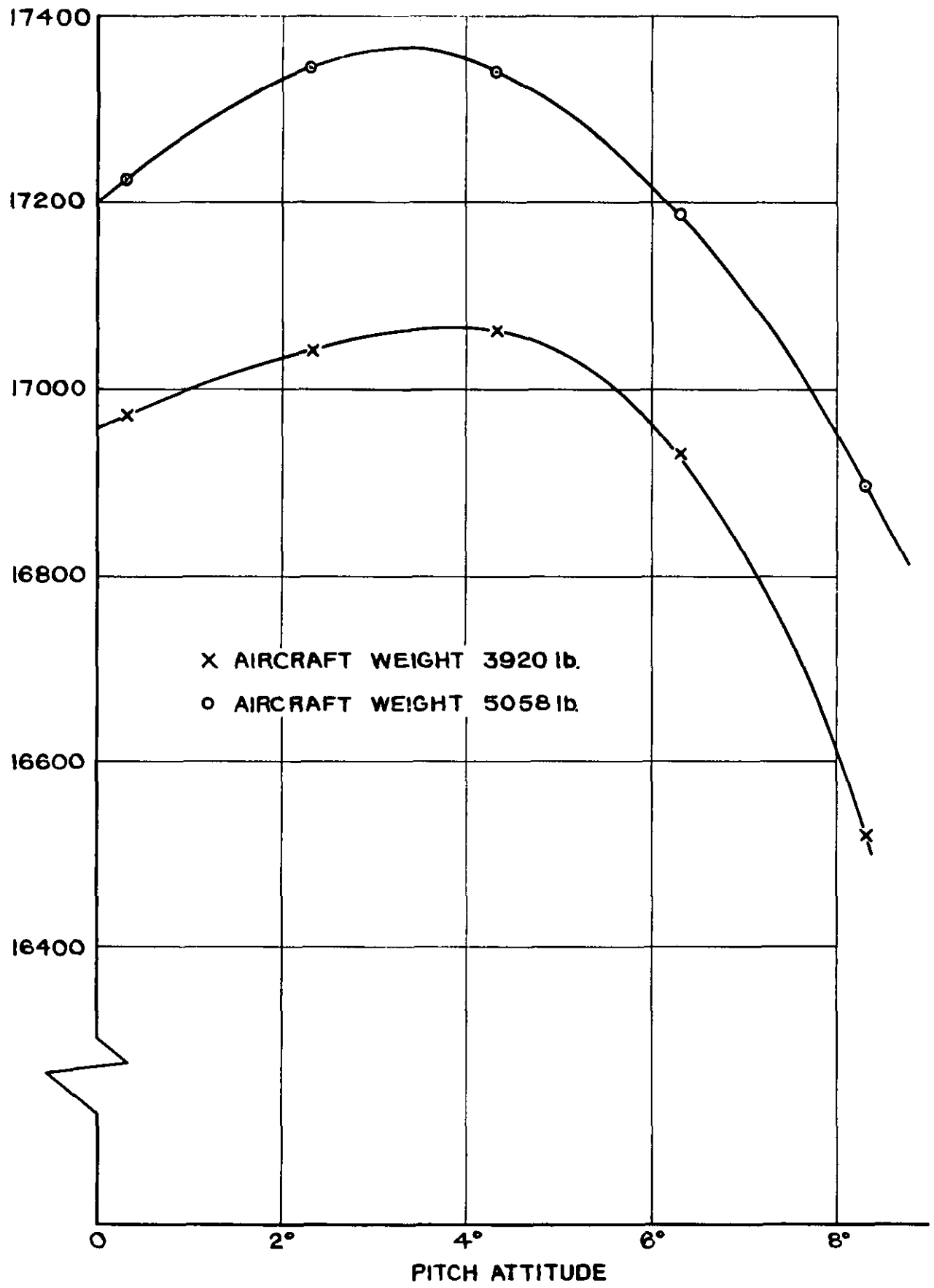

FIG. 13 VARIATION OF YAW MOMENT OF INERTIA WITH PITCH ATTITUDE

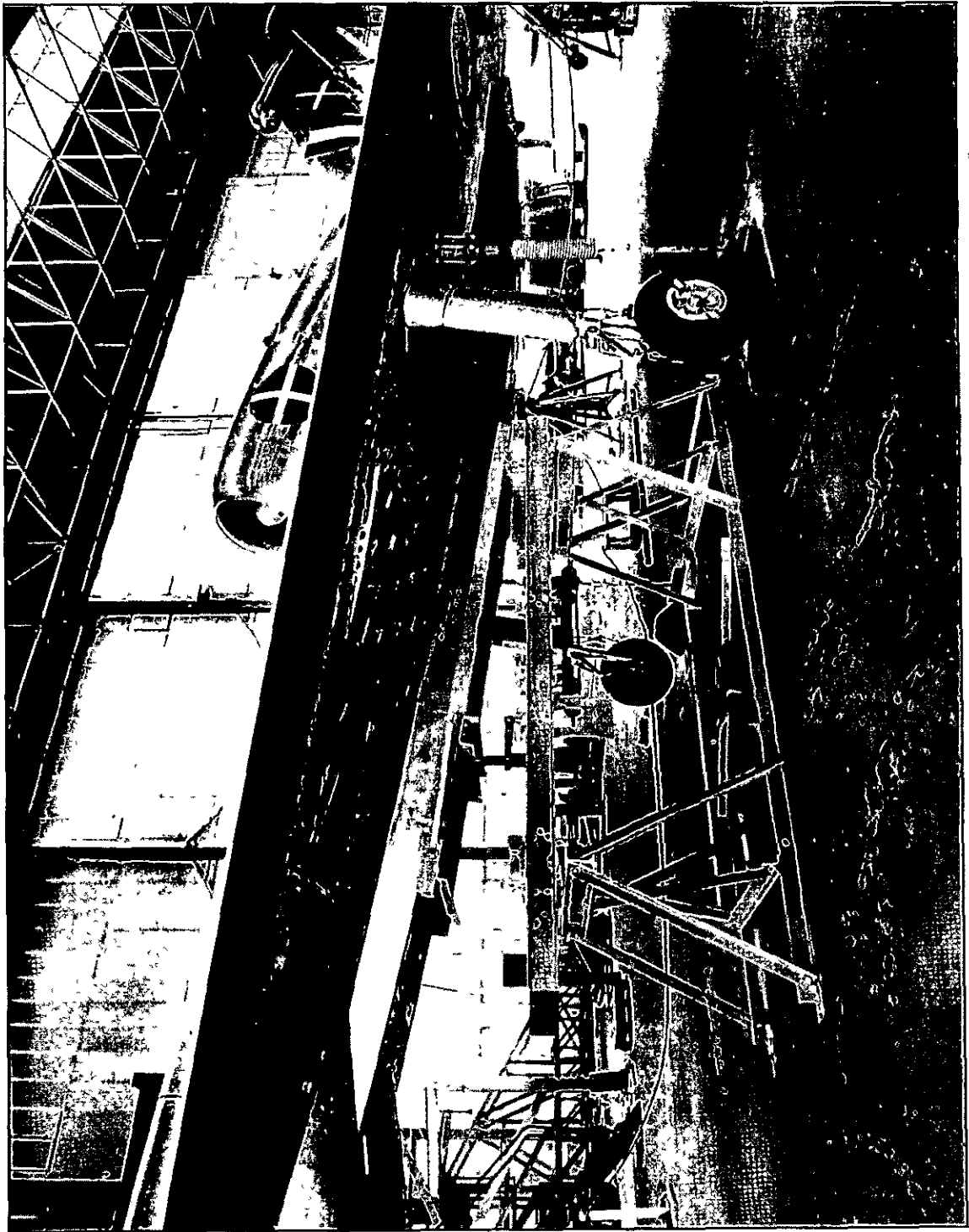

Fig.14. Aircraft on roll rig

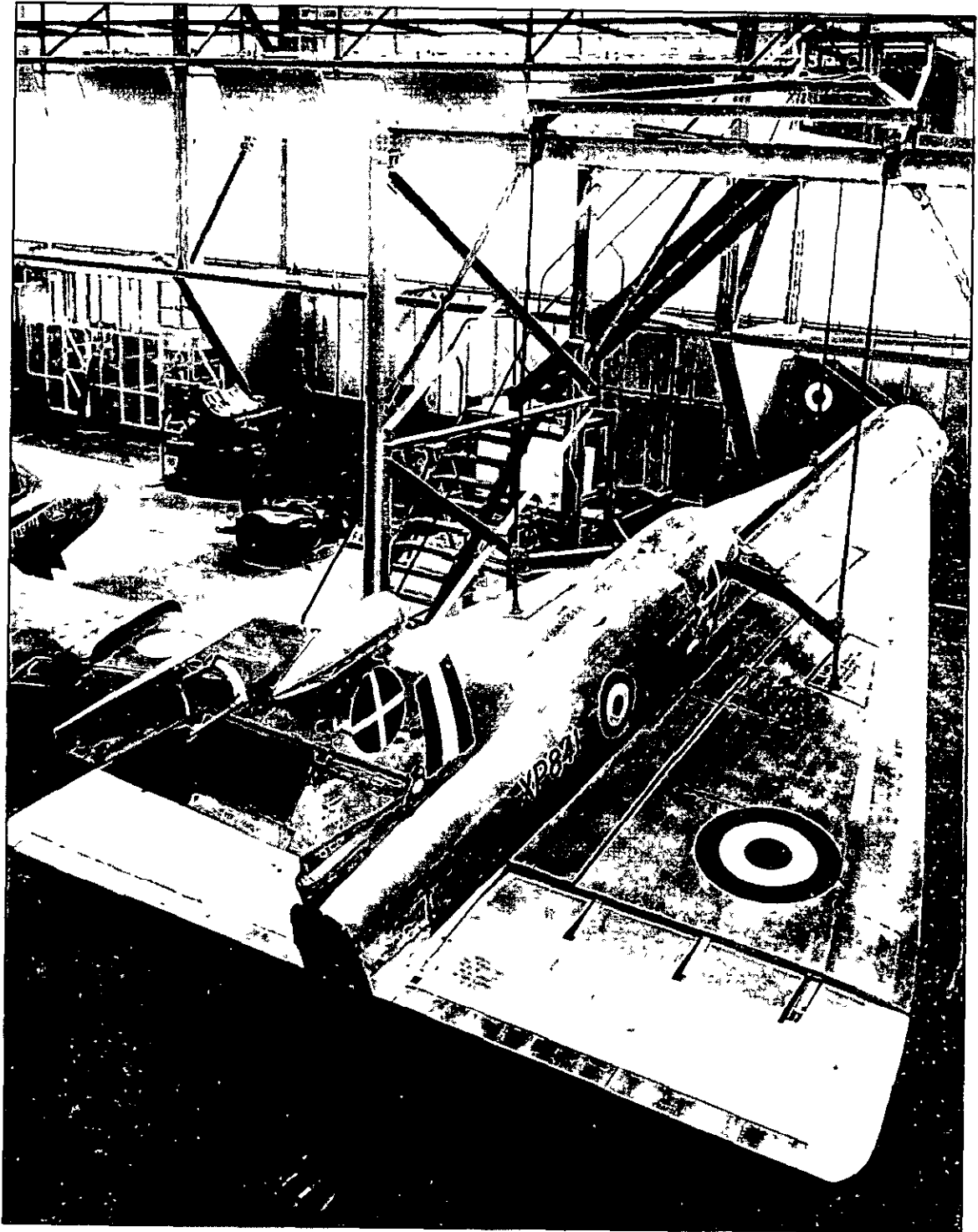

Fig.15. HP115 on yaw rig

*Printed in England for Her Majesty's Stationery Office by
the Royal Aircraft Establishment, Farnborough. Dd.125875.K.4.*

A.R.C. C.P. No.907
September 1965

531.231 +
533.6.013.152/154

Fennell, L.J.

MEASUREMENT OF THE MOMENTS OF INERTIA OF THE HANDLEY PAGE HP115 AIRCRAFT

Measurement of the moments of inertia in pitch, roll, and yaw, and of the inclination of the principal inertia axis have been made on the HP115 slender wing research aircraft. In pitch and roll a spring constrained oscillatory technique was used, while in yaw the aircraft was suspended as a torsional pendulum. The inclination of the principal inertia axis was found by varying the attitude of the aircraft on the rolling and yaw rigs. Measurements were made with fuel tanks full and empty.

An estimate of the accuracies of the techniques used showed that the inertias could be measured to within $\pm 2\%$, $\pm 5\%$ and $\pm 1\%$ for the pitch, roll, and yaw axes respectively. The inclination of the principal axes could be determined to within $\pm 0.1^\circ$.

A.R.C. C.P. No.907
September 1965

531.231 +
533.6.013.152/154

Fennell, L.J.

MEASUREMENT OF THE MOMENTS OF INERTIA OF THE HANDLEY PAGE HP115 AIRCRAFT

Measurement of the moments of inertia in pitch, roll, and yaw, and of the inclination of the principal inertia axis have been made on the HP115 slender wing research aircraft. In pitch and roll a spring constrained oscillatory technique was used, while in yaw the aircraft was suspended as a torsional pendulum. The inclination of the principal inertia axis was found by varying the attitude of the aircraft on the rolling and yaw rigs. Measurements were made with fuel tanks full and empty.

An estimate of the accuracies of the techniques used showed that the inertias could be measured to within $\pm 2\%$, $\pm 5\%$ and $\pm 1\%$ for the pitch, roll, and yaw axes respectively. The inclination of the principal axes could be determined to within $\pm 0.1^\circ$.

A.R.C. C.P. No.907
September 1965

531.231 +
533.6.013.152/154

Fennell, L.J.

MEASUREMENT OF THE MOMENTS OF INERTIA OF THE HANDLEY PAGE HP115 AIRCRAFT

Measurement of the moments of inertia in pitch, roll, and yaw, and of the inclination of the principal inertia axis have been made on the HP115 slender wing research aircraft. In pitch and roll a spring constrained oscillatory technique was used, while in yaw the aircraft was suspended as a torsional pendulum. The inclination of the principal inertia axis was found by varying the attitude of the aircraft on the rolling and yaw rigs. Measurements were made with fuel tanks full and empty.

An estimate of the accuracies of the techniques used showed that the inertias could be measured to within $\pm 2\%$, $\pm 5\%$ and $\pm 1\%$ for the pitch, roll, and yaw axes respectively. The inclination of the principal axes could be determined to within $\pm 0.1^\circ$.

After allowing for the virtual inertia of the surrounding air mass, the experimental values were less than the manufacturers estimates in pitch and roll but greater in yaw. The largest discrepancy was approximately 5%. The measured inclination of the principal axis was considerably less than the estimate, 3.95° instead of 5.1° .

After allowing for the virtual inertia of the surrounding air mass, the experimental values were less than the manufacturers estimates in pitch and roll but greater in yaw. The largest discrepancy was approximately 5%. The measured inclination of the principal axis was considerably less than the estimate, 3.95° instead of 5.1° .

After allowing for the virtual inertia of the surrounding air mass, the experimental values were less than the manufacturers estimates in pitch and roll but greater in yaw. The largest discrepancy was approximately 5%. The measured inclination of the principal axis was considerably less than the estimate, 3.95° instead of 5.1° .

C.P. No. 907

© Crown Copyright 1967

Published by
HER MAJESTY'S STATIONERY OFFICE

To be purchased from
49 High Holborn, London w c 1
423 Oxford Street, London w.1
13A Castle Street, Edinburgh 2
109 St Mary Street, Cardiff
Brazennose Street, Manchester 2
50 Fairfax Street, Bristol 1
35 Smallbrook, Ringway, Birmingham 5
80 Chichester Street, Belfast 1
or through any bookseller

C.P. No. 907

S.O. CODE No. 23-9017-7