

C.P. No. 570

LIBRARY
ROYAL AIRCRAFT ESTABLISHMENT
BEDFORD.

C.P. No. 570



MINISTRY OF AVIATION

AERONAUTICAL RESEARCH COUNCIL

CURRENT PAPERS

The Analysis of Complex Vibrations with Spada

by

S. L. Entres

LONDON: HER MAJESTY'S STATIONERY OFFICE

1961

PRICE 6s. 6d NET

U.D.C. No. 534.15 : 681.3.024 : 5.001.58 : 623.451-519

C.P. No. 570
June, 1960

THE ANALYSIS OF COMPLEX VIBRATIONS WITH SPADA

by

S. L. Intres

SUMMARY

This Note is concerned with a machine, known as SPADA, which has been designed for the purpose of analysing recorded G.W. vibrations. The theory underlying concepts such as frequency and amplitude distribution may be found scattered in the appropriate text-books or the relevant technical literature, but the absence of a comprehensive account dealing with the application of some of these theories to the analysis of recorded vibrations has led to widely diverging approaches. In describing the functioning of SPADA it is necessary to state in applied form some elementary concepts relevant to the analysis; particularly the spectral density, the probability distribution of amplitude and the sampling error are discussed. SPADA will be used both as a research instrument and as a facility available for the analysis of vibrations recorded by the G.W. industry and other establishments. Its use, however, is not restricted to vibration analysis. SPADA will, within its limitations, analyse any parameter which can be recorded on magnetic tape.

LIST OF CONTENTS

	<u>Page</u>
1 INTRODUCTION	3
2 THE PURPOSE OF SPADA	3
3 BASIC PERFORMANCE CHARACTERISTICS OF SPADA	4
4 THE ANALYSIS OF THE SPECTRAL DENSITY	4
5 THE ANALYSIS OF THE AMPLITUDE DISTRIBUTION	9
6 SUPPORTING DESIGN FEATURES	12
7 PROPOSED WORKING PROGRAMME	13
8 ACKNOWLEDGEMENT	13
LIST OF REFERENCES	13

APPENDICES 1 - 6	14 - 29
ILLUSTRATIONS - Figs. 1-16	-
DETACHABLE ABSTRACT CARDS	-

LIST OF ILLUSTRATIONS

	<u>Fig.</u>
Front view of SPADA	1
Tape loop splicer	2
Duplicator	3
The physical meaning of a noise sample	4
Normalised tape speed time function	5
Principle of spectral density analysis	6
Specimen of analysed spectral density	7
Overall frequency response of SPADA	8
Squared frequency response of filters	9
Amplitude distributions of some elementary time functions	10
Principle of amplitude distribution analysis	11
Specimen of analysed amplitude distribution	12
Percentage overestimate of standard error of spectral density	13
Recommended filter bandwidth for analysis	14
Maximum permissible standard error	15
Elementary wave forms	16

1 INTRODUCTION

An empirical vibration-time function is completely defined by its oscillogramme $y(t)$. For most theoretical and experimental purposes however, the graphical form is unsuitable, and a mathematical description of $y(t)$ is required. There are various numerical methods by which this can be achieved, the most relevant being the Fourier integral. If, however, $y(t)$ is a complicated function having many maxima and minima, and particularly when a large number of such functions must be dealt with, the need for data reduction equipment arises. This situation has existed for some time in the field of environmental vibrations, and different types of analysers have been devised or improvised by various workers.

A vibration analyser had previously been developed at R.A.E. This machine has now outlived its usefulness as a research tool for two reasons. Increased knowledge of environmental vibrations and of their simulation demands a more advanced approach to vibration analysis, and also, the machine is now wearing out, having been in use daily since the time of its introduction five years ago.

Two years ago, a new vibration analyser was designed at R.A.E. which has been manufactured by Rivlin Instruments, Camberley and which has recently been delivered. This machine is known as SPADA which is short for Spectral density and Amplitude Distribution Analyser.

This Note gives some of the background relevant to the analysis of samples of recorded environmental vibrations, and describes the way in which the various forms of analysis are accomplished by SPADA.

2 THE PURPOSE OF SPADA

Although our imperfect knowledge of environmental vibrations justifies the demand for more and better vibration data, the relatively few vibration recordings that are made already tax the resources available for analysis. An analysis of a vibration recording lasting 30 seconds, using the previous R.A.E. vibration analyser, took 1 or 2 man-days to yield the equivalent sine wave spectrum of the vibration. This estimate includes, of course, all ancillary work such as editing and duplicating of the tape, calibration, determining the recording frequency response, analysis proper (which takes only a few minutes), developing the paper, and finally presenting the data as a corrected spectrum. Although SPADA will not reduce greatly the overall time of vibration analysis, it will however give more data for a given amount of time spent. Moreover, SPADA will describe an empirical vibration-time function in mathematical forms which can be used directly for theoretical studies, for the design of test gear and for the formulation of various types of test specification.

There are two vibration characteristics which are of prime interest in this context. One is the spectral density of a vibration time function and the other is the probability distribution of the vibration amplitude. The former characteristic tells us how the quadratic content of vibration is distributed over the frequency range, and the latter, with the help of the former, will indicate important structural features of the vibration such as periodic elements, non-stationary properties and other patterns.

SPADA plots directly the spectral density and the amplitude distribution of signals recorded on magnetic tape. The degree of frequency resolution and the signal sampling time are controllable within such limits as are needed to cover a wide field of research on vibration and acoustic noise.

3 BASIC PERFORMANCE CHARACTERISTICS OF SPADA

A front view of SPADA is shown in Fig.1. The machine accepts loops of magnetic tape 24.0 cm long which are cut and spliced on a special device (Fig.2). The signal to be analysed is amplitude modulated upon such a loop by the Tape Duplicator (Fig.3), normally at a tape speed of 16 cm/s. Standard $\frac{1}{4}$ in. wide tape of instrument quality is used.

The method of analysing the spectral density and the amplitude distribution is described in paragraphs 4.3 and 5.2 respectively. Both the spectral density and the amplitude distribution are plotted with ink on 10 in. wide paper by an x - y servo controlled recorder. The spectral density is plotted on co-ordinates which are approximately logarithmic, and the amplitude distribution is plotted on linear co-ordinates.

The performance ranges of SPADA are as follows:-

(i) Standard frequency range of analysis

10 c/s to 10 Kc/s. The frequency range may be extended beyond the above limits by duplicating the signal on the tape loop at the appropriate tape speed.

(ii) Frequency resolution

The analysing filters may be adjusted to the following values of relative effective bandwidth: $\delta_{\text{eff}} = 25\%$, 12.5%, 6% and 3%. Information about filters will be found in paragraph 4.4.

(iii) Standard amplitude range

Three times RMS amplitude in each the positive and negative direction of amplitude. The effective amplitude range may, if necessary, be further extended with a proportional increase of the noise to signal ratio.

(iv) Amplitude resolution

A maximum of 16 points per RMS amplitude in the amplitude distribution plot, giving a total of 96 points over the standard amplitude range of six times the RMS amplitude.

(v) Integration time (sampling time)

Continuously variable from approximately 0.1 sec to 15 sec true time. Integration is performed between two fixed limits t_1 and t_2 which may be adjusted independently. The sampling error is discussed in paragraph 4.2.

4 THE ANALYSIS OF THE SPECTRAL DENSITY

4.1 The concept of a spectral density and its moving average

If $y(t) \int_{t_1}^{t_2} dt$ denotes a vibration time function recorded over a period

$t_2 - t_1$, then from what is known as the "Fourier Integral Energy Identity", follows the equality (see Appendix 1)

$$\frac{1}{t_2 - t_1} \int_{t_1}^{t_2} y^2(t) dt = \int_0^{\infty} \sigma^2(f) df \quad .$$

Where $\sigma^2(f_i)df$ is the mean taken over the period $t_2 - t_1$ of the squared amplitude of the frequency components of $y(t)$ $\int_{t_1}^{t_2}$ in the small frequency

interval $f_i, f_i + df$. $\sigma^2(f)$ has, thus, the character of a density the dimension of which is (dimension of y)²/c.p.s. A simple dimensional analysis will reveal that the spectral density is proportional to the power density of the vibration if y stands for the velocity of the vibration. It is, however, no longer true to speak of $\sigma^2(f)$ as a power spectrum if, as it is more often the case, y denotes the acceleration of the vibration.

Given $\sigma^2(f)$, the mean square amplitude $(y_{\text{RMS}})^2 \int_{t_1}^{t_2}$ in any band

$\Delta f = f_2 - f_1$ may be obtained by summing the right hand side of the above equality from f_1 to f_2

$$(y_{\text{RMS}})^2 \int_{t_1}^{t_2} \int_{f_1}^{f_2} = \int_{f_1}^{f_2} \sigma^2(f) df \quad .$$

$\sigma^2(f)$ will have an average value $\overline{\sigma^2} \int_{f_1}^{f_2}$ in the band $f_2 - f_1$ which must satisfy

the equality

$$\overline{\sigma^2} \int_{f_1}^{f_2} (f_2 - f_1) = (y_{\text{RMS}})^2 \int_{t_1}^{t_2} \int_{f_1}^{f_2} \quad .$$

This average value $\overline{\sigma^2} \int_{f_1}^{f_2}$ of the spectral density in the band $f_2 - f_1$ may be

easily determined by, say, passing the vibration $y(t) \int_{t_1}^{t_2}$ through a filter of known bandwidth Δf , and measuring the mean square output $(y_{\text{RMS}})^2 \int_{t_1}^{t_2} \int_{f_1}^{f_2}$. Then

$$\overline{\sigma^2} \Big|_{f_1}^{f_2} = \frac{(y_{RMS})^2 \Big|_{t_1}^{t_2} \Big|_{f_1}^{f_2}}{\Delta f} .$$

If this process is repeated at frequency intervals Δf through the entire frequency range, a moving average plot $\overline{\sigma^2(f)}_{\Delta f}$ of the spectral density may be obtained. SPADA analyses essentially by this method the spectral density. The curve $\overline{\sigma^2(f)}_{\Delta f}$ has, thus, the character of a double average, being a mean over the time period $t_2 - t_1$ as well as a mean over a frequency band of width Δf .

The desired resolution with respect to time may be effected by the choice of the time interval $t_2 - t_1$, and the desired resolution of frequency detail may be obtained by the choice of bandwidth Δf . This aspect will be dealt with in the next paragraph 4.2 where the sampling error is discussed.

4.2 The sampling error

When inferring the population value of a statistic from data taken from a sample, an error, the so-called sampling error, is inevitable. This sampling error is also committed when estimating the population value of the spectral density of a vibration from measurements on a sample of vibration lasting $t_2 - t_1$ seconds. (This sampling error should not be confused with the error that is due to any inaccuracies of the equipment contained in SPADA. The latter type of error is additional to the sampling error.) A measure for the sampling error is the standard deviation of the sampling distribution of the statistic under consideration, which is termed the standard error of the statistic. The standard error is thus a measure of the variability obtained when measuring a statistic (in our case the spectral density) on a number of samples taken from the same population. The sampling error depends on the sample size and decreases with increasing sample size.

For the case of a vibration time function which has the characteristic of random noise it can be shown (see Appendix 2) that the standard error, when determining the spectral density of a vibration from a sample of size n , is

$$S_e \approx \frac{56.5}{\sqrt{n}} \quad \%$$

which is a sufficiently close approximation within the relevant range of vibration analysis.

The sample size n is defined here as

$$n = T \Delta f$$

where $T = t_2 - t_1 =$ duration of vibration, or sample length

$\Delta f =$ bandwidth being investigated by the analysing filter or sample

The taking of a sample of a vibration time function may thus be conceived in simplified form as cutting out a block from the spectral density-time function whose rectangular base is defined by two quantities, frequency bandwidth of analysing filter and time over which the squared amplitude is integrated, (see Fig.4).

It is sound practice to analyse vibrations with a sampling error which is equal or less than the error inherent in the vibration measuring, transmitting and recording process. Therefore, that combination of T and Δf should be chosen for analysis which ensures this condition. It is suggested that for general analysis work the standard error of the spectral density should not be greater than

$$S_e \leq 40 f^{-1/3} \% .$$

There is generally less freedom in choosing Δf than in choosing T. If, for example, Δf is made too small then the analyser is forced to look into irrelevant frequency details which missile equipment is unlikely to see, apart from the fact that the sample length T will have to be correspondingly increased, which may reduce the number of vibration samples that can be transmitted through one telemetry channel.

It is, therefore, recommended that, unless dictated otherwise, the relative bandwidth of analysis is adjusted to approximately

$$\delta = \frac{\Delta f}{f} \approx f^{-1/3}$$

which fixes the sample length T for all frequencies at a value of about two seconds.

4.3 The principle of deriving the spectral density with SPADA

Unless the bandwidth of the analysing filter is made infinitesimally small the spectral density $\sigma^2(f)$ itself cannot be obtained. A moving average $\sigma^2(f)$, however, can be measured, and as long as the conditions of the standard error discussed in paragraph 4.2 (and in Appendix 2) are fulfilled, $\overline{\sigma^2}(f)$ may be regarded from a practical point of view as synonymous with $\sigma^2(f)$. In the following the qualification "moving average" of the spectral density is therefore dropped for the sake of brevity.

The principle of spectral density analysis is simple. The vibration to be analysed is fed through a filter of known centre frequency and bandwidth Δf . The output of the filter is first squared, then integrated over a period T, and finally divided by both T and Δf . This process yields the spectral density in the frequency range Δf . It will be noted that only passive networks are needed. If this procedure is repeated for adjacent frequency bands Δf , or if the frequency range is slowly scanned, a plot of spectral density against frequency may be obtained.

Although SPADA conforms to this basic principle of spectral density analysis, it does not explore the frequency range in the original time scale. In SPADA the centre frequency of the analysing filter is kept constant and the tape loop bearing the signal to be analysed is replayed at a changing tape speed.

The tape speed-time function is so arranged that during one revolution of the tape the frequency being looked at is shifted by one quarter of the relative bandwidth of the analysing filter, and that any change of bandwidth will automatically adjust the speed function to its correct characteristic. This process of inverse scanning which has also been used on the previous R.A.E. vibration analyser achieves much the same end as if the filter centre frequency were swept through the desired frequency range and the tape loop replayed at a constant speed. This reversal of duties, however, reduces considerably the complexity and the volume of the necessary electronic gear. Particularly the analysing filter becomes a simple fixed parallel - T network, only narrow band amplification is needed and hum can be entirely avoided. The tape play back speed of SPADA falls monotonically from 160 to 16 cm/s (see Fig.5). This 10 : 1 speed ratio is equivalent to a frequency scan from f to $10f$. In order to cover the frequency range from 10 c/s to 10 Kc/s three filters are necessary which have their centre frequencies tuned to 100 c/s, 1 Kc/s and 10 Kc/s respectively.

Fig.6 shows in diagrammatic form the sequence of main events leading to the spectral density plot. (For key to Fig.6 see Appendix 5).

The vibration sample $y(t) \int_0^T$ is duplicated at the speed v on a loop L of

magnetic tape. This loop is transferred to SPADA and replayed at a speed V which decreases according to Fig.5 from $10v$ to v . The magnetic replay head

H_2 sees the time transformed signal $Y(t) \int_0^{Tv/V}$ which is fed into the filter

F of fixed centre frequency F_0 and relative bandwidth δ . The output of this

filter $Y(t) \int_{F_1}^{F_2} \int_0^{Tv/V}$ which contains only frequency components within the

band $F_2 - F_1$ is then squared by the squarer S_q and integrated. The integrator I receives the signal to start and to stop integration from a pulse p . Two holes punched into the tape loop, one at the beginning and the other at the end of the recorded vibration sample, permit some light from the bulb B to pass to the photocell Ph which generates the required pulse p . The integral

$$\int_0^{Tv/V} Y^2(t) \int_{F_1}^{F_2} dt$$

is multiplied first by the time transformed and inverse time base V/Tv in the multiplier M_1 , and then multiplied again by the inverse of the relative

bandwidth $1/\delta$ in the second multiplier M_2 which yields a voltage $C_1 \sigma^2 \int_{f_1}^{f_2}$

proportional to the average of the spectral density of $y(t) \int_0^T$ in the original

frequency band $f\delta = f_2 - f_1$, where $f = \frac{v F_0}{V}$.

For ease of presentation the spectral density is plotted by the recorder R on a log - log scale. The output of M_2 is, therefore, modified by the logarithmic shaper Lg. The logarithmic frequency function for the recorder is obtained from the shaper Sh. Both shapers, Lg and Sh, are servos using suitably distorted feedbacks. Both the multiplier M_1 and the shaper Sh receive a signal which is proportional to the play back tape speed V, and which is derived from the tape speed programming unit Pr, a servo which generates also the speed characteristic shown in Fig.5. Fig.7 shows a specimen record of an analysed spectral density.

4.4 Technical aspects of spectral density analysis

Some difficulties arise in practice which require departures from the principle of spectral density analysis as outlined in paragraph 4.2, and which are due to non-linearities and other shortcomings in the physical properties of practical equipment. Two problems are prominent. The first is connected with the fact that the frequency resolution of a magnetic tape head decreases when the wavelength of the signal on the tape decreases with signal frequency, and approaches the width of the gap of the magnet. To compensate for the resulting deficiency of the tape heads in frequency response, correcting networks have been interposed which make use of the voltage proportional to the play back tape speed V which is available from the programming unit Pr (of Fig.6). The overall frequency response of SPADA, with the deliberate lift in the third decade, is shown in Fig.8. The other problem is the filter whose response cannot be made to approximate a rectangular shape without causing coherence, a phenomenon which may lead to a significant interaction of the signal to be analysed with itself. In order to avoid coherence* at all costs, simple parallel - T networks have been used as filters. The three filters are built as plug-in units so that filter circuit changes may easily be made in the future. The squared frequency response of SPADA's present filters is shown in Fig.9. The deviation from the 'ideal' response is apparent from the superposed equivalent rectangle which possesses the same area but a wider bandwidth. This bandwidth may be considered as the effective bandwidth δ_{eff} of the filter, and is for SPADA's filters given by

$$\delta_{eff} = 1.5 \times \delta .$$

5 THE ANALYSIS OF THE AMPLITUDE DISTRIBUTION

5.1 The concept of a probability density of the amplitude

When dealing with an empirical vibration-time function $y(t) \int_{t_1}^{t_2}$, such

as a recorded sample of environmental vibration of duration $t_2 - t_1$, one may want to know for what fraction of the time the amplitude y has exceeded a certain magnitude y_1 . If, say, the time function is available in graphical form one may draw a line parallel to the time axis through y_1 and measure the

cumulative time $\sum_{t_1}^{t_2} t_i$ for which the amplitude remained above y_1 . This process

*Coherence is fully discussed in Ref.1.

may be repeated for $y_j = y_i + \Delta y$, yielding the corresponding cumulative time

$$\sum_{t_1}^{t_2} t_j. \text{ Subtracting } \sum_{t_1}^{t_2} t_i - \sum_{t_1}^{t_2} t_j \text{ we obtain the cumulative time } \sum_{t_1}^{t_2} \Delta t \text{ during}$$

which the amplitude remained in this interval Δy . Therefore $\frac{1}{t_2 - t_1} \sum_{t_1}^{t_2} \Delta t$

denotes the proportion of time $P(y, y + \Delta y)$ which the amplitude y has spent in the interval Δy . It will be noted that P depends both on y and on the size of the interval Δy . In order to remove the effect of Δy we take the average over this interval Δy and get

$$\frac{P(y, y + \Delta y)}{\Delta y} = \bar{p}_{\Delta y} = \frac{1}{(t_2 - t_1) \Delta y} \sum_{t_1}^{t_2} \Delta t = \frac{1}{t_2 - t_1} \sum_{t_1}^{t_2} \frac{\Delta t}{\Delta y}$$

which assumes the character of a density indicating the proportion of ampli-

tude dwell per amplitude interval, and having the dimension $\frac{\text{seconds}}{\text{dimension of amplitude}}$

If the oscillogramme is explored in this manner over the entire recorded amplitude range a histogram $\bar{p}(y)_{\Delta y}$ representing a moving average of the distribution of the amplitude y is obtained.

As Δy tends to zero the histogram goes over to the smooth curve of what is also known as the probability density of the amplitude (see Appendix 5),

$$p(y) = \lim_{\Delta y \rightarrow 0} \bar{p}(y)_{\Delta y} = \lim_{\Delta y \rightarrow 0} \frac{1}{t_2 - t_1} \sum_{t_1}^{t_2} \frac{\Delta t}{\Delta y} = \frac{1}{t_2 - t_1} \sum_{t_1}^{t_2} \frac{dt}{dy} \int_{y=-\infty}^{y=+\infty} .$$

Analogously to the analysis of the spectral density the process outlined before will not give the probability density $p(y)$ itself but a moving average $\bar{p}(y)_{\Delta y}$ instead, for the amplitude interval Δy cannot be made infinitesimally small in practice.

SPADA analyses a moving average of the amplitude distribution employing a principle which is essentially as described above. The signal to be analysed

however, is recorded on a tape loop (it is in fact the same loop from which the spectral density is derived), and played back into a circuit which sees sequentially the signal in adjacent amplitude intervals of size Δy . The desired resolution is achieved by assigning a suitable value to Δy .

The usefulness of the amplitude distribution lies in the fact that its shape is very sensitive to the character of the vibration-time function which is not easily revealed by the spectral density. Amplitude distributions of some elementary time functions worked out in Appendix 4 and plotted in Fig.10 will show this property.

5.2 The method of deriving the amplitude distribution with SPADA

The principle of amplitude distribution analysis adopted for SPADA is shown in schematic form in Fig.11. (For key to Fig.11 see Appendix 6.)

A vibration sample $y(t)$ $\int_{t_1}^{t_2}$ is recorded on a loop L of magnetic tape at

the speed $v = 16$ cm/s. The loop is transferred to SPADA, played back at the same speed, and the RMS value r of the replayed signal is measured by the RMS meter E. Having measured r , whose value is needed to calibrate the amplitude distribution plot, the loop is replayed continuously at the constant speed v . The two holes punched into the tape loop L, one at the beginning and the other at the end of the recorded vibration sample, permit light from the bulb B to pass to the photocell Ph, which generates pulses p . These pulses enter into the staircase generator St which produces a voltage y_i which is, starting from zero, increased in steps of Δy at every revolution of the tape loop L. This

voltage y_i is added to the replayed signal $y(t)$ $\int_{t_1}^{t_2}$ by the network A, and fed into the cathode ray tube G. The face of this tube is blackened except for a

fixed, small slot Δy through which $y_i + y(t)$ $\int_{t_1}^{t_2}$ may be seen by the photoeell

Ph₂. Ph₂ generates pulses whose durations Δt are proportional to the varying

times for which $y_i + y(t)$ $\int_{t_1}^{t_2}$ is visible in the slot Δy . The magnitude of each

pulse, however, depends on the velocity with which the light spot happens to travel across the slot. A secondary pulse generator P amplifies and clips the primary pulses, and renders them suitable for summation by the integrator I which is triggered by the pulse p to start and terminate integration. The integrated voltage is first multiplied by $1/\Delta y$ in the multiplier M_1 , then multiplied by the inverse vibration sample length $\frac{1}{t_2 - t_1}$ in the second multiplier

M_2 , and finally fed into the y-axis of the recorder R. In order to obtain the normalised presentation of the amplitude distribution the x-axis of the recorder receives a transformed amplitude z_i (in multiples of the RMS amplitude) which

ranges from -3 to $+3$. z_i is obtained by multiplying the y-shift voltage y_i , generated by the staircase generator St, with the inverse $1/r$ of the RMS value, the latter having been determined at the beginning of the analysis.

Normally only the positive half of the amplitude distribution is plotted from $z = 0$ to $z = +3$. The negative half, however, may be added if so desired. The amplitude distribution is plotted in normalised form on a doubly linear scale so that kurtosis and any skew with respect to a theoretical distribution may easily be determined.

Provision is also made to analyse the amplitude distribution between two frequency limits $f_2 - f_1$ by inserting one of the three filters used in the spectral density analysis between the tape head H_2 and the adding network A, and adjusting the playback tape speed accordingly by means of the tape speed programme unit Pr. Fig. 12 shows a specimen record of an analysed amplitude distribution.

5.3 Technical aspects of amplitude distribution analysis

The photo-electric method of extracting the time function $y(t)$ in the interval Δy has been preferred to an all-electronic solution on the grounds of expediency and basic simplicity. The slot on the tube face is inherently stable, and the signal cut-off is clean with the chosen configuration of slot width, cathode ray spot diameter and distance between tube face and photocell.

Another method, however, was considered involving a "slot" which is represented by a metal ribbon stretching across the inner side of the tube face and acting as a collector for the electron beam. This attractive solution, however, was no further pursued in view of the extra development time needed.

The width of the slot in SPADA's cathode ray tube is 6 mm which corresponds normally to an amplitude interval of

$$\Delta y = \frac{y_{RMS}}{16}$$

regardless of the shape of the amplitude distribution. This standard resolution of 96 readings over an amplitude range of $6 y_{RMS}$ may, of course, be altered if so desired.

6 SUPPORTING DESIGN FEATURES

A rapid check whether or not SPADA is functioning correctly is made by analysing a tape loop prepared for this purpose which contains a sample of "white noise", that is random noise with a frequency independent spectral density function. Both the spectral density and the amplitude distribution sector may thus be tested. In addition there is provided a built-in meter with a loose lead that can be plugged into various jacks mounted on the front panels. These jacks are connected to vital circuit points required to be in balance or to have certain potentials.

Interlocks are provided to the extent that SPADA will not start analysis unless the necessary operating sequence has been completed, and the servos have reached zero. On completion of analysis, which is indicated by a light, SPADA comes to rest. Pressing a reset button returns the machine to the "start analysis" condition.

7 PROPOSED WORKING PROGRAMME

SPADA is primarily a research instrument. Some problems which will be studied with its help are concerned with the detailed nature of vibration and acoustic environments. We do not know today whether we are justified in treating environmental flight vibrations as a random process. Quite likely, significant elements of non-randomness or even periodicity may play a rôle. It may also be that randomness is associated with certain frequency bands only. Other problems to be investigated are concerned with the distribution of vibration energy throughout a missile and with the non-stationary character of flight vibrations which both have a vital influence on any vibration test specification. SPADA will assist in determining the extent to which vibration simulation, and if necessary programming, with present type of test gear is successful.

In order to be able to draw general conclusions a large number of environmental records need be analysed. Among special studies such as mentioned before it is intended to use the machine for the routine analysis of environmental recordings made by both R.A.E. and various G.W. design authorities. The analysed data will, it is hoped, provide the basis for a refined and comprehensive survey of the vibration and acoustic environments occurring under different conditions of G.W. use. The success of this undertaking will, however, depend on the co-operation of G.W. contractors.

8 ACKNOWLEDGEMENT

The design and development of SPADA required close team work. Mr. D.E. Mullinger and Mr. A.W.G. Utting, both of R.A.E., have taken an active part in the design of SPADA, and have made innumerable and valuable contributions. Messrs. Rivlin Instruments of Camberley have engineered this unusual type of equipment.

LIST OF REFERENCES

<u>Ref. No.</u>	<u>Author</u>	<u>Title, etc.</u>
1	Mullinger, D.E.	The development of a random motion vibration system. Unpublished M.O.A. Report.
2	Goldman, S.	Frequency analysis, modulation and noise. McGraw Hill Book Co. Inc.
3	Hopian, D.	Fluctuations of random noise power. The Bell System Tech. Journal, Volume XXXVII.

APPENDIX 1

If $y(t)$ represents a vibration time function then the Fourier Integral Identity states that

$$\begin{aligned} y(t) &\equiv \int_0^{\infty} a(\omega) \cos \omega t \, d\omega + \int_0^{\infty} b(\omega) \sin \omega t \, d\omega \\ &= \int_0^{\infty} c(\omega) \cos [\omega t + \phi(\omega)] \, d\omega \end{aligned}$$

where $c(\omega) = \sqrt{a^2(\omega) + b^2(\omega)}$ is the frequency distribution of $y(t)$, and

$$a(\omega) = \frac{1}{\pi} \int_{-\infty}^{+\infty} y(t) \cos \omega t \, dt$$

$$b(\omega) = \frac{1}{\pi} \int_{-\infty}^{+\infty} y(t) \sin \omega t \, dt \quad .$$

From the Fourier Integral Energy Identity follows that

$$\int_{-\infty}^{+\infty} y^2(t) \, dt \equiv \pi \int_0^{\infty} c^2(\omega) \, d\omega = \text{total quadratic content of } y(t) \quad .$$

If $y(t) = 0$, except for $t_1 \leq t \leq t_2$, as is the case with a vibration sample of duration $t_2 - t_1$, then likewise

$$a(\omega) = \frac{1}{\pi} \int_{t_1}^{t_2} y(t) \cos \omega t \, dt$$

$$b(\omega) = \frac{1}{\pi} \int_{t_1}^{t_2} y(t) \sin \omega t \, dt$$

and the total quadratic content of $y(t)$ $\int_{t_1}^{t_2}$ becomes

$$\int_{t_1}^{t_2} y^2(t) dt = \pi \int_0^{\infty} c^2(w) dw .$$

Division by $t_2 - t_1$ leads to the mean square of $y(t)$ $\int_{t_1}^{t_2}$ taken over the entire period $t_2 - t_1$. Substituting $2\pi df$ for dw , we get

$$\frac{1}{t_2 - t_1} \int_{t_1}^{t_2} y^2(t) dt = \frac{2\pi^2}{t_2 - t_1} \int_0^{\infty} c^2(f) df = \int_0^{\infty} \sigma^2(f) df$$

where $\sigma^2(f)$ is the spectral density of $y(t)$ $\int_{t_1}^{t_2}$ in terms of mean square amplitude per unit bandwidth as a function of frequency f .

The relationship between the Fourier frequency distribution and the spectral density follows from the above equation

$$c(f) = \frac{1}{\pi} \sqrt{\frac{t_2 - t_1}{2}} \sigma(f) .$$

The spectral density of a signal $y(t)$ $\int_{t_1}^{t_2}$ may be measured directly with

a passive system consisting of filters followed by a squarer and an integrator. When attempting to determine directly the frequency distribution $c(w)$, however, an active system will be needed which generates pairs of orthogonal frequency components.

APPENDIX 2

The standard error of the mean square value of a white noise passing through a linear single degree of freedom system (or through a filter feedback network such as used in SPADA) of bandwidth $\Delta\omega$ is given by (see also Ref. 3)

$$S_e = 100 \sqrt{\frac{2}{N}} \times C \quad \% \quad (1)$$

where $N = T \Delta\omega =$ size of the noise sample

$T =$ time over which the squared output of the filter is integrated

$C =$ correction factor.

The square root in (1) has the familiar appearance of the standard error of the variance.

Putting

$$\Delta\omega = 2\pi f\delta$$

where $f =$ centre frequency of filter in c.p.s. of the recording time scale

$\delta =$ relative bandwidth of filter

we can write

$$N = 2\pi T f\delta = 2\pi n$$

where $n = T f\delta$, (2)

a dimensionless quantity, is the characteristic sample size.

With this notation, the standard error of the mean square value passing through the filter becomes

$$S_e = \frac{56.5}{\sqrt{n}} \times C \quad \% \quad (3)$$

and the correction factor C is defined by

$$C^2 = 1 - \frac{1}{2\pi n} \left[1 - e^{-2\pi n} - \frac{2\delta}{4-\delta} e^{-2\pi n} \sin^2 \pi n \sqrt{\frac{4}{\delta} - 1} \right] . \quad (4)$$

For small values of δ , such as used by SPADA, the term containing \sin^2 becomes small compared with unity, and (4) reduces to

$$C^2 \approx 1 - \frac{1}{2\pi n} \left(1 - e^{-2\pi n} \right) .$$

C is now a function of the characteristic sample size n alone, and tends to unity for large n. The percentage error when taking C as unity is

$$e = 100 \frac{1 - C}{C} \quad \%$$

and is plotted in Fig.13 against the characteristic sample size n. For values of $n > 8$ the percentage error by which the standard error of the mean square value is overestimated becomes less than 1%. The simplified expression for the standard error of the mean square value (from (3))

$$S_e \approx \frac{56.5}{\sqrt{n}} \quad \% \quad (5)$$

is, therefore, sufficiently accurate for general vibration work.

For a given T, the standard error S_e is determined by the bandwidth $f\delta$ of the filter. Since SPADA derives the mean square per unit frequency band (or spectral density) at frequency f by dividing through $f\delta$ the mean square value passed by the filter, the percentage standard error associated with the spectral density at the frequency f is also S_e , for reasons of proportionality.

The standard error of the spectral density at the frequency f is, using (2) and (5)

$$S_e \approx \frac{56.5}{\sqrt{n}} = \frac{56.5}{\sqrt{T f \delta}} \quad \% \quad (6)$$

By putting a limit on the tolerable standard error S_e the minimum sample size n_o of noise required for analysis becomes (from (6))

$$n_o = T f \delta = \left(\frac{56.5}{S_e} \right)^2 \quad (7)$$

The minimum permissible time duration of a sample of noise, consistent with the tolerable standard error, follows from (7)

$$T_o = \frac{n_o}{f_L \delta} \quad (8)$$

where f_L = lowest frequency which is of interest

δ = relative analysing bandwidth appropriate to the frequency range in question.

T_o may, of course, be shortened by making δ larger. This, however, is not advisable for general vibration analysis. The δ of the analysing filter should be comparable to the δ of the dynamic responses of the equipment which is exposed to the vibration. As a guide, the relationship

$$\delta \approx f^{-1/3} \quad (9)$$

is suggested (this is equivalent to $\Delta f \approx f^{2/3}$ as proposed in SP 32).

Analysing with a $\delta \gg f^{-1/3}$ will inevitably result in a loss of frequency detail, and making $\delta \ll f^{-1/3}$ forces the analyser to look for frequency details which are unlikely to be seen by the vibrated equipment (apart from unnecessarily increasing the analysis time).

(9) is shown in Fig. 14, and the δ -steps used by SPADA to approximate (9) are superposed. These steps correspond approximately to the mid-points of δ in each analysis band.

The standard error of analysis should not exceed the standard error associated with the process of sensing, transmitting, tape recording and playing back of noise data. The standard error of recorded vibrations tends to decrease with increasing frequency in the normal operating range. At 30 c/s its value is estimated to be of the order of 15% and at 1000 c/s about 5%.

It is, therefore, recommended that for general vibration analysis work the standard error of the spectral density is limited to

$$S_e \leq 40 f^{-1/3} \% \quad (10)$$

This function is shown in Fig. 15.

Using (7), (8), (9) and (10) we can find the minimum permissible time duration of a vibration recording (sample of vibration) which will not exceed the condition (10)

$$T_0 = \frac{56.5^2}{S_e^2 f \delta} = \frac{3190}{1600 f^{-2/3} f f^{-1/3}} \approx 2 \text{ seconds} \quad .$$

T_0 happens not to be dependent on frequency.

APPENDIX 3

An ideal magnetic recording head, when energised with a signal voltage

$$y(t) = y_0 \sin 2\pi ft$$

produces a time varying magnetic field of strength

$$\phi(t) = a y_0 \sin 2\pi ft$$

which is imprinted in the tape as a permanent magnetic field, varying with tape distance according to

$$\Phi(\ell) = b y_0 \sin \frac{2\pi \ell}{\lambda}$$

where $\ell = vt =$ distance by which the tape has travelled

$v =$ recording tape speed

$\lambda = \frac{v}{f} =$ wave length of f in terms of distance on tape.

If $\Phi(\ell)$ is played back at the tape speed V the play back frequency of the signal is changed to

$$F = \frac{V}{\lambda} = \frac{V}{v} f = \rho f \quad (11)$$

where $\rho =$ tape speed ratio.

On play back $\Phi(\ell)$ is transformed into $\Phi(t)$

$$\Phi(t) = b y_0 \sin 2\pi Ft \quad .$$

$\Phi(t)$ produces in the play back head an EMF which is proportional to $-\frac{d\Phi}{dt}$.
The voltage-time function generated by the magnetic head is

$$Y(t) = c F y_0 \cos 2\pi Ft \quad .$$

where c is a machine constant.

The amplitude of the replayed signal is, thus

$$Y_o = c F y_o \quad . \quad (12)$$

The record-playback frequency response follows, using (12),

$$R = \frac{Y_o}{y_o} = \frac{c F y_o}{y_o} = c F \quad .$$

Let $y(t)$ now be the recorded time function of a complex or a random (noise) signal voltage having a spectral density $\sigma^2(f)$. Consider a frequency band $f_2 - f_1$, which is so small that the spectral density within this band may be regarded as constant. If the playback tape speed is made ρ -times the recording tape speed, then this frequency band is, according to (11), widened on playback by the factor ρ , and its frequency limits are now

$$F_1 = \rho f_1$$

$$F_2 = \rho f_2$$

The mean square voltage of the replayed signal, is, of course, affected by the record-playback frequency response, and it is, within the limits $F_2 - F_1$,

$$\overline{Y^2} \int_{F_1}^{F_2} = \sigma^2 \int_{F_1}^{F_2} R^2(f) dF \quad .$$

The spectral density σ^2 , being a constant, may precede the integral sign. Inserting the frequency function proper for $R^2(f)$, we obtain

$$\overline{Y^2} \int_{F_1}^{F_2} = c^2 \sigma^2 \int_{F_1}^{F_2} F^2 dF = \frac{c^2 \sigma^2}{3} (F_2^3 - F_1^3)$$

If F_o denotes the centre frequency, and if F_2 and F_1 stand for the upper and lower limits of the effective bandwidth of the analysing filter, then

$$F_1 = F_o \left(1 - \frac{\delta}{2} \right)$$

$$F_2 = F_o \left(1 + \frac{\delta}{2} \right)$$

where δ = effective relative bandwidth of analysing filter, and we get

$$\overline{Y^2} \int_{F_1}^{F_2} = c^2 \sigma^2 F_o^3 \left[\delta + \frac{\delta^3}{12} \right] \quad .$$

Since F_0^3 is a constant and $\frac{\delta^3}{12}$ is very small, we can simplify

$$\frac{\overline{Y^2}}{F_1^2} \approx d \sigma^2 \delta \quad .$$

The mean square output of the analysing filter is proportional to the spectral density of the recorded noise signal. SPADA, by its design, corrects for the variation in actual bandwidth of the analysing filter which is associated with a constant relative bandwidth (or, if one likes, a constant Q). The setting of the relative bandwidth is a question of appropriate gain calibration.

APPENDIX 4

The amplitude of a vibration-time function $y(t)$ observed over the period $t_1 \leq t \leq t_2$ dwells in the interval $y, y + dy$ for a cumulative time $\sum dt$. The proportion of time for which the amplitude is confined within the band $y, y + dy$ is, therefore,

$$p(y) dy = \frac{1}{t_2 - t_1} \sum_{t_1}^{t_2} dt$$

where $p(y)$ is called the probability density of the amplitude, and is

$$p(y) = \frac{1}{(t_2 - t_1) dy} \sum_{t_1}^{t_2} dt = \frac{1}{t_2 - t_1} \sum_{t_1}^{t_2} \frac{dt}{dy} \Big|_{y=-\infty}^{y=+\infty} .$$

It is easy to see that the area under the curve $p(y)$ must be unity, for

$$\int_{-\infty}^{+\infty} p(y) dy = \frac{1}{t_2 - t_1} \int_{-\infty}^{+\infty} \left(\sum_{t_1}^{t_2} \frac{dt}{dy} \right) dy = 1$$

meaning that it is certain that the amplitude y is at all times between the limits $-\infty = y = +\infty$.

It is frequently more convenient to work with the normalised probability density of the amplitude

$$p(z) = \frac{1}{t_2 - t_1} \sum \frac{dt}{dz}$$

in which the instantaneous amplitude y is replaced by standard units z , that is, y is expressed in multiples z of the RMS value r of $y(t) \Big|_{t_1}^{t_2}$. Thus

$$y = r z$$

and

$$r = \frac{1}{t_2 - t_1} \int_{t_1}^{t_2} y^2(t) dt .$$

In the following the amplitude distributions of some elementary functions are derived (see also Fig.10).

(i) Sine wave

Function $y = \sin wt$

Inverse function $t = \frac{1}{w} \arcsin y$

$$\frac{dt}{dy} = \frac{1}{w\sqrt{1-y^2}} \cdot$$

Normalising the amplitude

$$y = rz; \quad dy = r dz$$

we get

$$\frac{dt}{dz} = \frac{1}{w\sqrt{\frac{1}{r^2} - z^2}} \cdot$$

If the range of observation is conveniently chosen, say,

$$t_2 - t_1 = T = \frac{2\pi}{w}, \text{ then}$$

$$\sum \frac{dt}{dz} = 2 \frac{dt}{dz}$$

because the sine wave crosses twice in this range through any interval $z, z + dz$ (or $y, y + dy$), where $-\frac{1}{r} \leq z \leq \frac{1}{r}$ (or $-1 \leq y \leq 1$).

Thus, the normalised amplitude distribution of a sine wave becomes

$$p = \frac{1}{T} \frac{2}{w\sqrt{\frac{1}{r^2} - z^2}} = \frac{1}{\pi\sqrt{\frac{1}{r^2} - z^2}} \cdot$$

Since the RMS of a sine wave of unit amplitude is

$$r = \frac{1}{\sqrt{2}}$$

we get

$$p(z) = \frac{1}{\pi\sqrt{2 - z^2}} \int_{z=-\sqrt{2}}^{z=+\sqrt{2}} \cdot$$

It is quickly verified that the area under this normalised probability density is unity

$$\int_{-\sqrt{2}}^{+\sqrt{2}} p(z) dz = \frac{1}{\pi} \int_{-\sqrt{2}}^{+\sqrt{2}} \frac{dz}{\sqrt{2-z^2}}$$

which becomes, since

$$\int \frac{dx}{\sqrt{a^2-x^2}} = \arcsin \frac{x}{a} + C$$

$$\int_{-\sqrt{2}}^{+\sqrt{2}} p(z) dz = \frac{1}{\pi} [\arcsin 1 - \arcsin (-1)] = 1$$

The total probability of the normalised amplitude z being between the limits $-\sqrt{2}$ and $+\sqrt{2}$ is unity (this corresponds to the amplitude y being between the limits -1 and $+1$).

(ii) Triangular wave or saw tooth

(The argument is restricted to such waves as have equal positive and negative maximum excursions and no direct component.)

From Fig.16(a) follows that the value of the function $y = f(t)$ is in the

<u>Range</u> I	$y = \frac{1}{a} t \Big _0^a$;	$\left \frac{dt}{dy} \right = a$
II	$y = 1 - \frac{1}{\frac{T}{2} - a} t \Big _{\frac{T}{2}}^{\frac{T}{2}}$;	$\left \frac{dt}{dy} \right = \frac{T}{2} - a$
III	$y = \frac{1}{b - \frac{T}{2}} t \Big _{\frac{T}{2}}^b$;	$\left \frac{dt}{dy} \right = b - \frac{T}{2}$
IV	$y = -1 + \frac{1}{\frac{T}{2} - b} t \Big _b^{\frac{T}{2}}$;	$\left \frac{dt}{dy} \right = \frac{T}{2} - b$

Normalising the amplitude

$$y = rz; \quad dy = r dz$$

<u>Range</u> I	$\left \frac{dt}{dz} \right = ra$
II	$\left \frac{dt}{dz} \right = r \left(\frac{T}{2} - a \right)$
III	$\left \frac{dt}{dz} \right = r \left(b - \frac{T}{2} \right)$

Range

$$\text{IV} \quad \left| \frac{dt}{dz} \right| = r (T - b) \quad .$$

From Fig. 16(a) follows that over the range $t_2 - t_1 = T$, and for the period of positive excursion:

$$\sum \frac{dt}{dz} = ra + r \left(\frac{T}{2} - a \right) = r \frac{T}{2} \quad .$$

Thus, the normalised probability density of the amplitude becomes

$$p = \frac{r \frac{T}{2}}{T} = \frac{r}{2} \int_{z=0}^{z=\frac{1}{r}} \quad .$$

Similarly, we have for the period of negative excursion

$$\sum \frac{dt}{dz} = r \left(b - \frac{T}{2} \right) + r(T - b) = r \frac{T}{2}$$

and

$$p = \frac{r}{2} \int_{z=-\frac{1}{r}}^{z=0} \quad .$$

The probability density of amplitude of the triangular wave does, therefore, not depend on z . The RMS of this wave having unit amplitude is simply derived from geometrical considerations. The RMS of the total wave must be equal to that of each triangle in the ranges I to IV. Taking that of Range I, we have

$$r = \sqrt{\frac{1}{a} \int_0^a f^2(t) dt} = \sqrt{\frac{1}{a^3} \int_0^a t^2 dt} = \frac{1}{\sqrt{3}} \quad .$$

Inserting this value into the expression for p

$$p = \frac{1}{2\sqrt{3}} = 0.289 \int_{z=-\sqrt{3}}^{z=+\sqrt{3}} \quad .$$

To verify that the area under this normalised probability density is unity we solve

$$\int_{-\sqrt{3}}^{+\sqrt{3}} p dz = \frac{1}{2\sqrt{3}} \int_{-\sqrt{3}}^{+\sqrt{3}} dz = \frac{1}{2\sqrt{3}} (\sqrt{3} + \sqrt{3}) = 1 \quad .$$

(iii) Square wave

From the square wave of Fig.16(b) follows that the value of the time function $y = g(t)$ is in the

$$\text{Range} \\ \text{I} \quad y = 1 \quad \left/ \begin{array}{l} T \\ 2 \\ 0 \end{array} \right.$$

$$\left| \frac{dt}{dy} \right| = \infty \text{ at } y = 1$$

$$\text{II} \quad y = -1 \quad \left/ \begin{array}{l} T \\ \frac{T}{2} \end{array} \right.$$

$$\left| \frac{dt}{dy} \right| = \infty \text{ at } y = -1$$

Normalising the amplitude, we have

$$y = rz; \quad dy = r dz$$

The RMS of the above square wave is $r = 1$, so that

Range

$$\text{I} \quad \left| \frac{dt}{dz} \right| = \infty \text{ at } z = 1$$

$$\text{II} \quad \left| \frac{dt}{dz} \right| = \infty \text{ at } z = -1$$

From Fig.16(b) follows further that over the range $t_2 - t_1 = T$, and for the period of positive excursion we have

$$\sum \frac{dt}{dz} = \left| \frac{dt}{dz} \right| = \infty$$

Similarly, for the period of negative excursion

$$\sum \frac{dt}{dz} = \left| \frac{dt}{dz} \right| = \infty$$

The probability density of amplitude of the square wave of Fig.16(b) is therefore

$$p = \frac{\infty}{T} = \infty \text{ at } z = -1 \text{ and } z = +1,$$

elsewhere $p = 0$.

(iv) Random noise

The probability density of the amplitude of random noise is not derived here as this subject is well treated in the relevant text-books (see also Ref.2).

The amplitude distribution of random noise is the familiar Normal Distribution which is, in our normalised notation,

$$p(z) = \frac{1}{\sqrt{2\pi}} e^{-\frac{z^2}{2}} \Big|_{z=-\infty}^{z=+\infty} .$$

It will be noted that in contrast to the former three distributions the probability density of the amplitude of theoretical random noise is not cut off at finite amplitudes.

APPENDIX 5

KEY TO FIGURE 6

B	light bulb
$C_{1,2}$	constants
F	filter
F_0	centre frequency of filter
F_1, F_2	limits of filter bandwidth
f	frequency in original time scale
f_1, f_2	limits of filter bandwidth in original time scale
H_1	recording tape head
H_2	playback tape head
I	integrator
L	tape loop
L_g	logarithmic shaper
$M_{1,2}$	multipliers
Ph	photocell
Pr	tape speed programming unit
p	pulse for integrator start and discharge, triggered by perforations punched in tape loop
R	servo controlled x - y recorder
Sh	shaper
Sq	squarer
t	real time
T	duration of signal sample in real time
v	recording tape speed (16 cm/s)
V	playback tape speed ($10v \rightarrow v$)
y	amplitude of signal to be analysed
Y	amplitude of time transformed signal
δ	relative bandwidth of filter
σ^2	spectral density of $y(t)$

APPENDIX 6

KEY TO FIGURE 11

A	Adding network
B	light bulb
C	cathode ray tube, face blackened except for slot Δy
E	RMS - meter
H_1	recording tape head
H_2	playback tape head
I	integrator
L	tape loop
$M_{1,2,3}$	multipliers
P	secondary pulse generator
$Ph_{1,2}$	photocells
Pr	tape speed programming unit
p	pulse for integrator start and discharge, triggered by perforations punched in tape loop
R	servo controlled x - y recorder
St	staircase generator
t	time
$t_{1,2}$	time limits of signal sample
v	recording tape speed
y	amplitude of signal to be analysed
y_i	magnitude of y - shift
z	amplitude of signal to be analysed in standard units
z_i	magnitude of z - shift

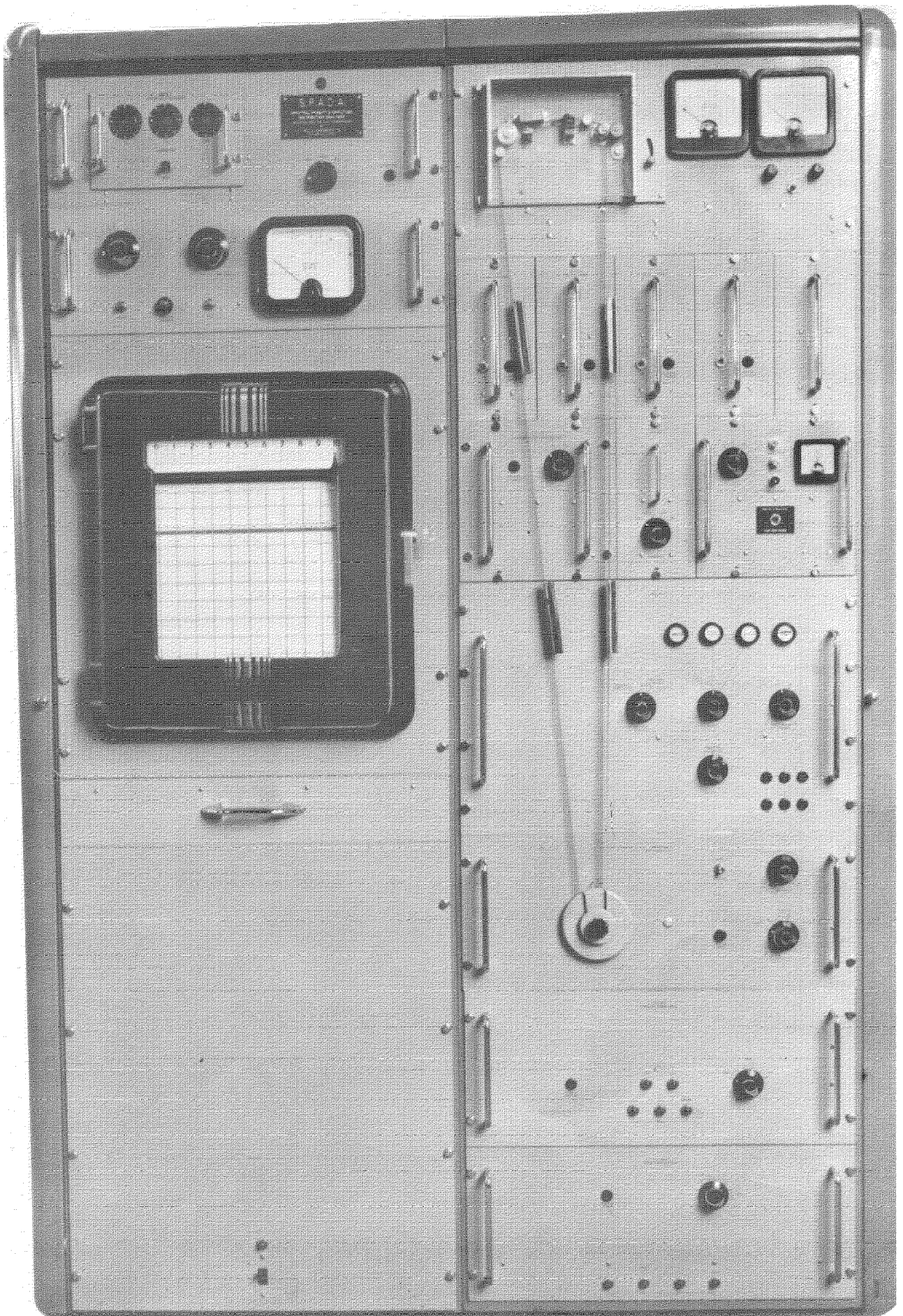

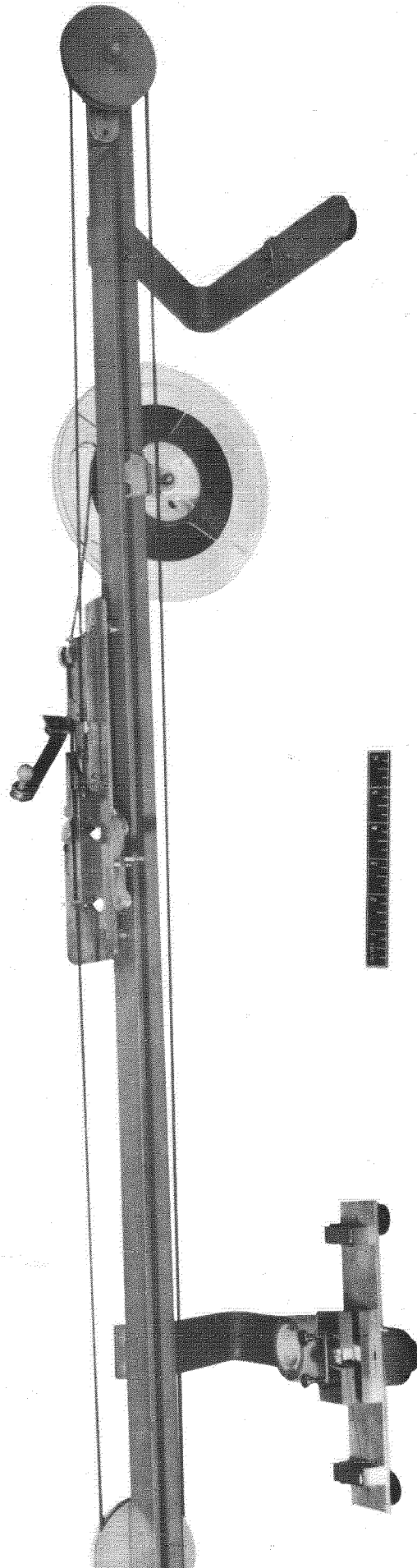

FIG.2. TAPE LOOP SPLICER

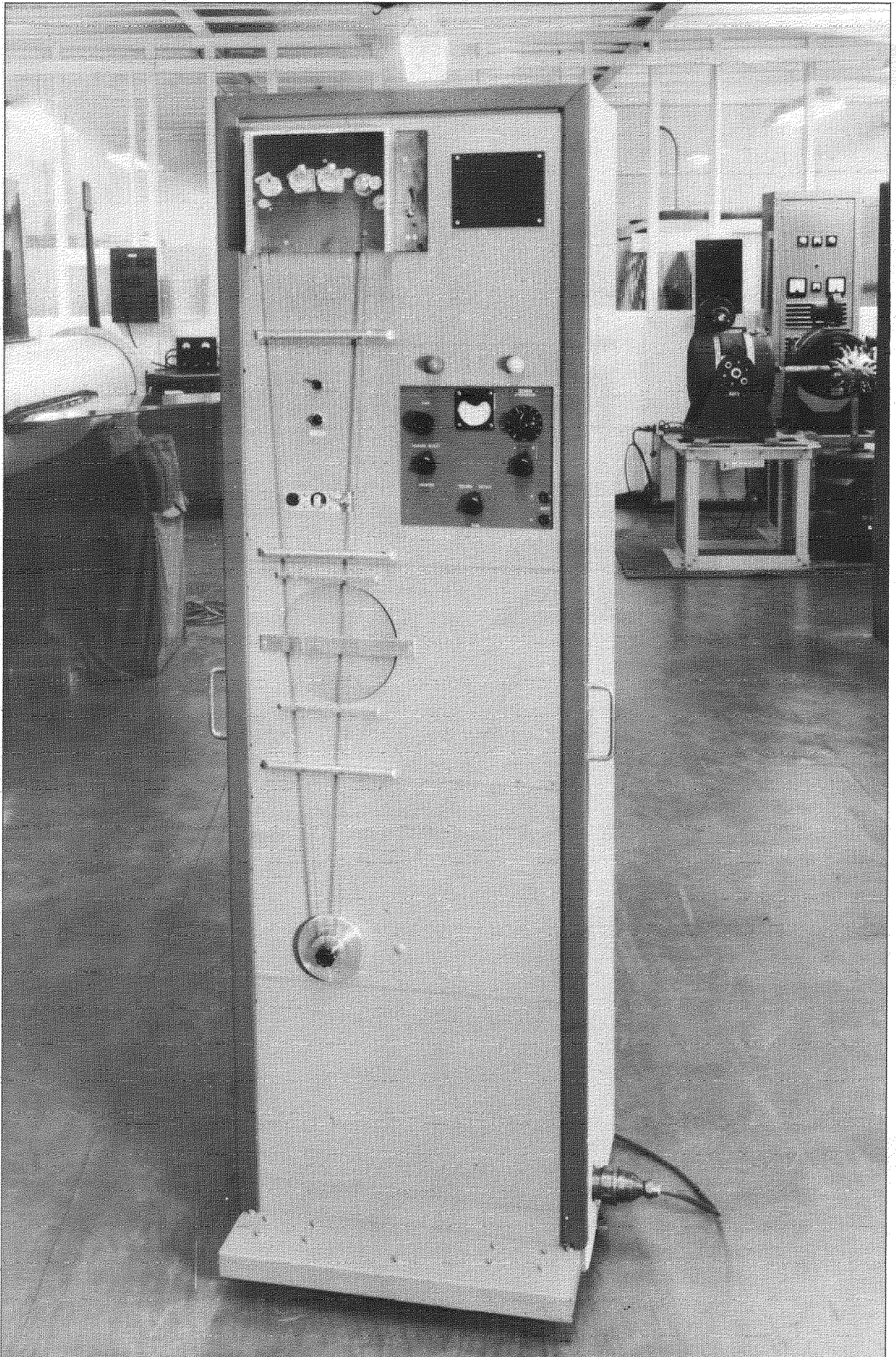

FIG.3. DUPLICATOR

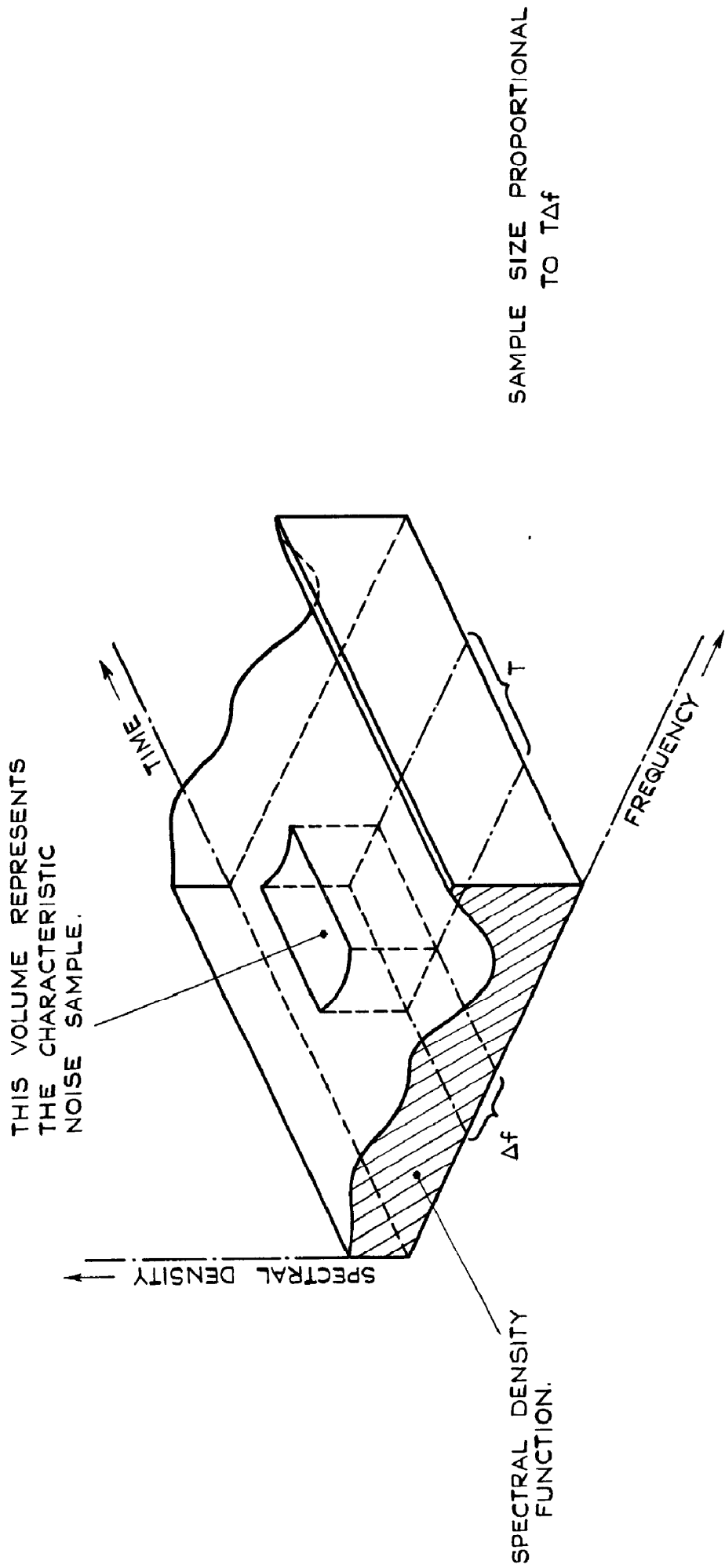

FIG. 4. THE PHYSICAL MEANING OF A NOISE SAMPLE.

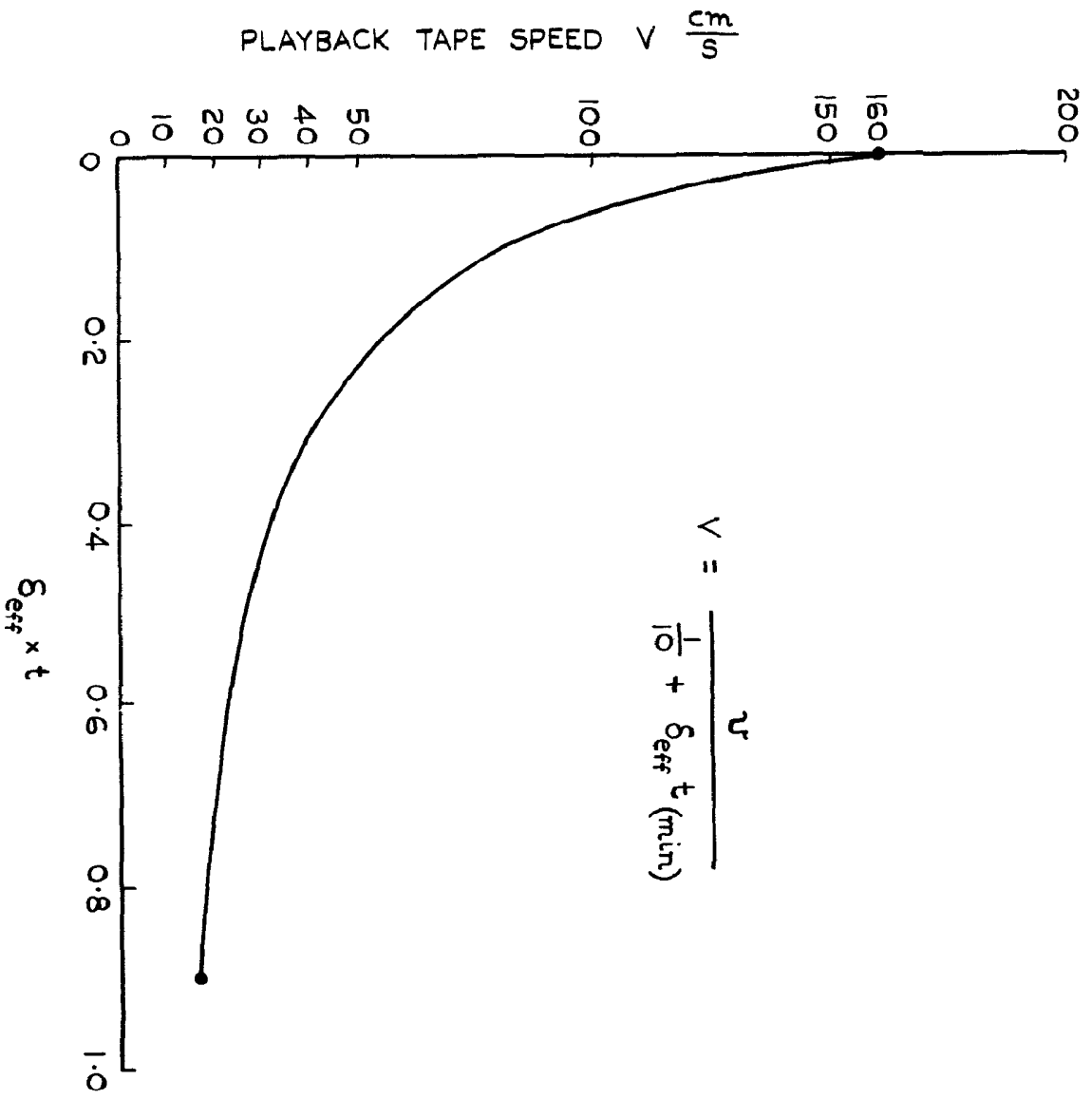
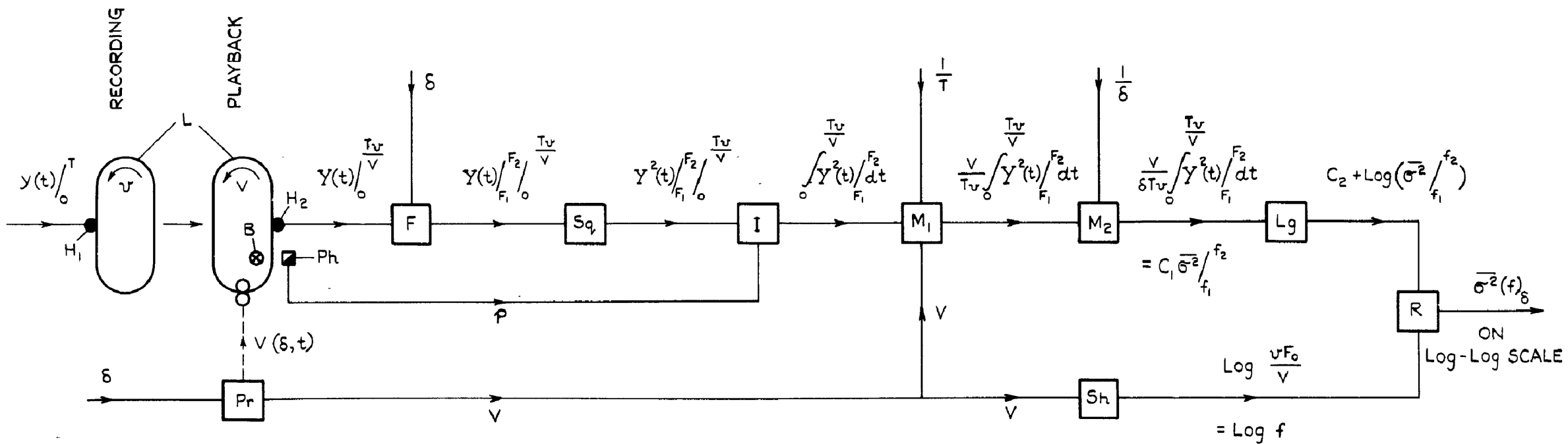

FIG. 5. NORMALISED TAPE SPEED
TIME FUNCTION.



FOR KEY TO THIS FIGURE
SEE APPENDIX 5.

FIG. 6. PRINCIPLE OF SPECTRAL DENSITY ANALYSIS.

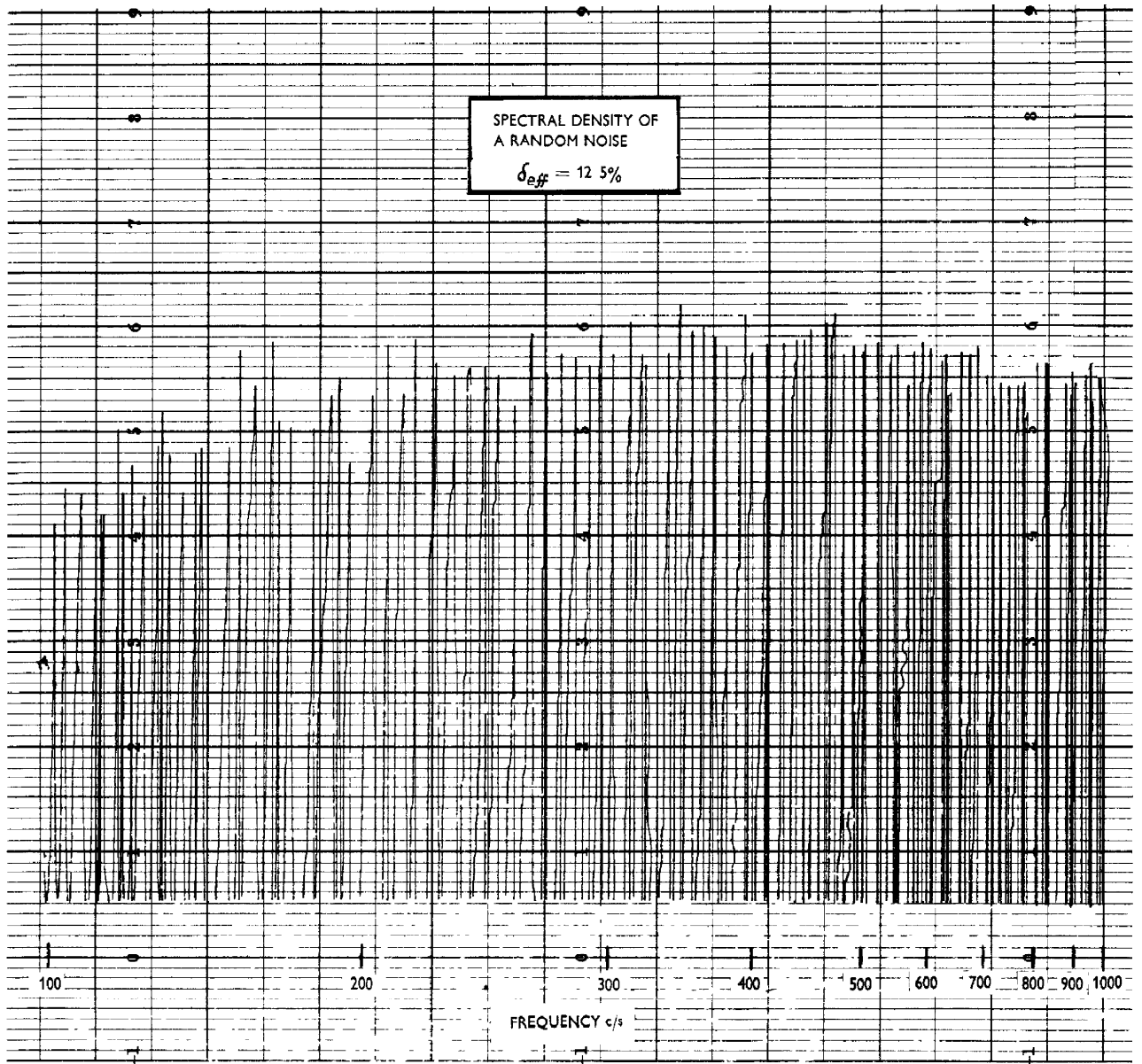

FIG.7. SPECIMEN OF ANALYSED SPECTRAL DENSITY

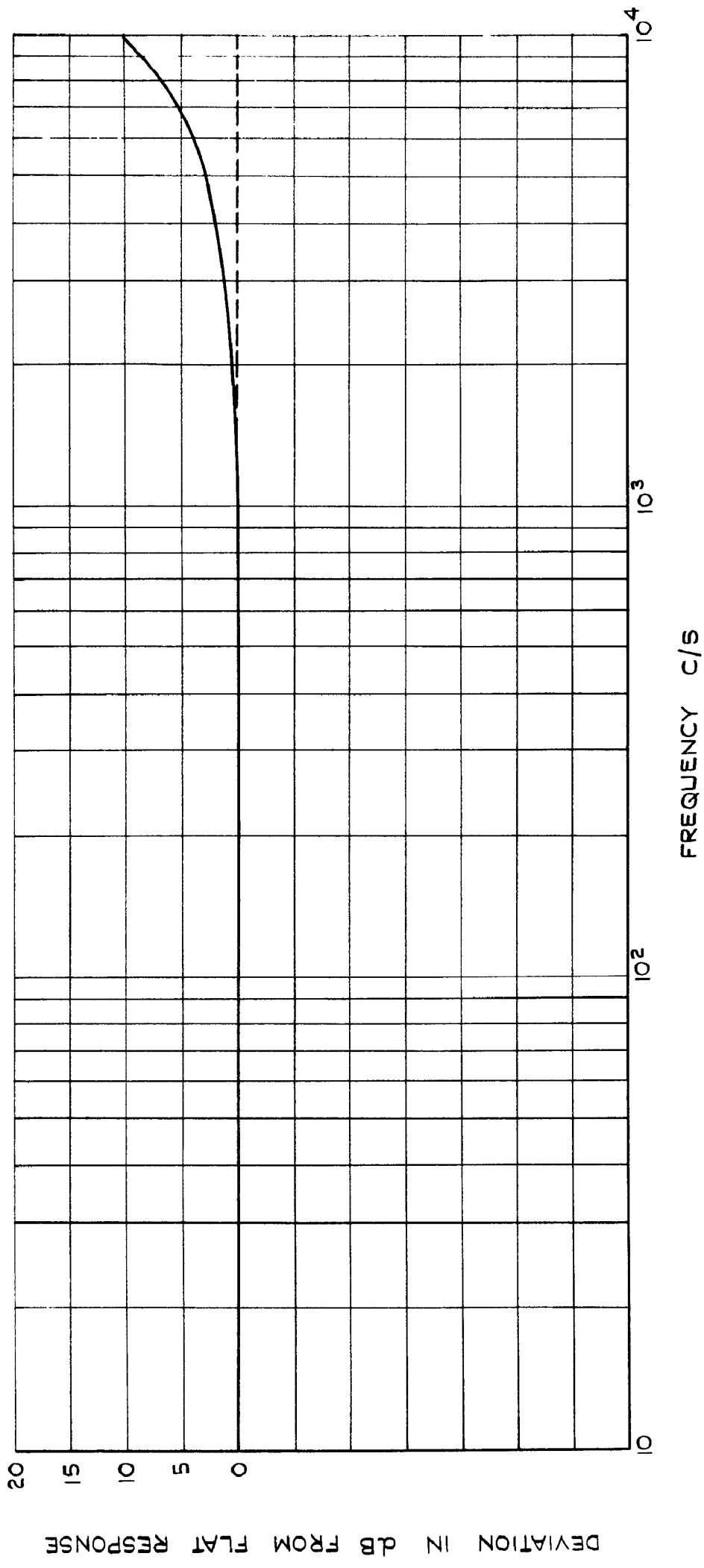

FIG. 8. OVERALL FREQUENCY RESPONSE OF SPADA.

SQUARED FILTER RESPONSE

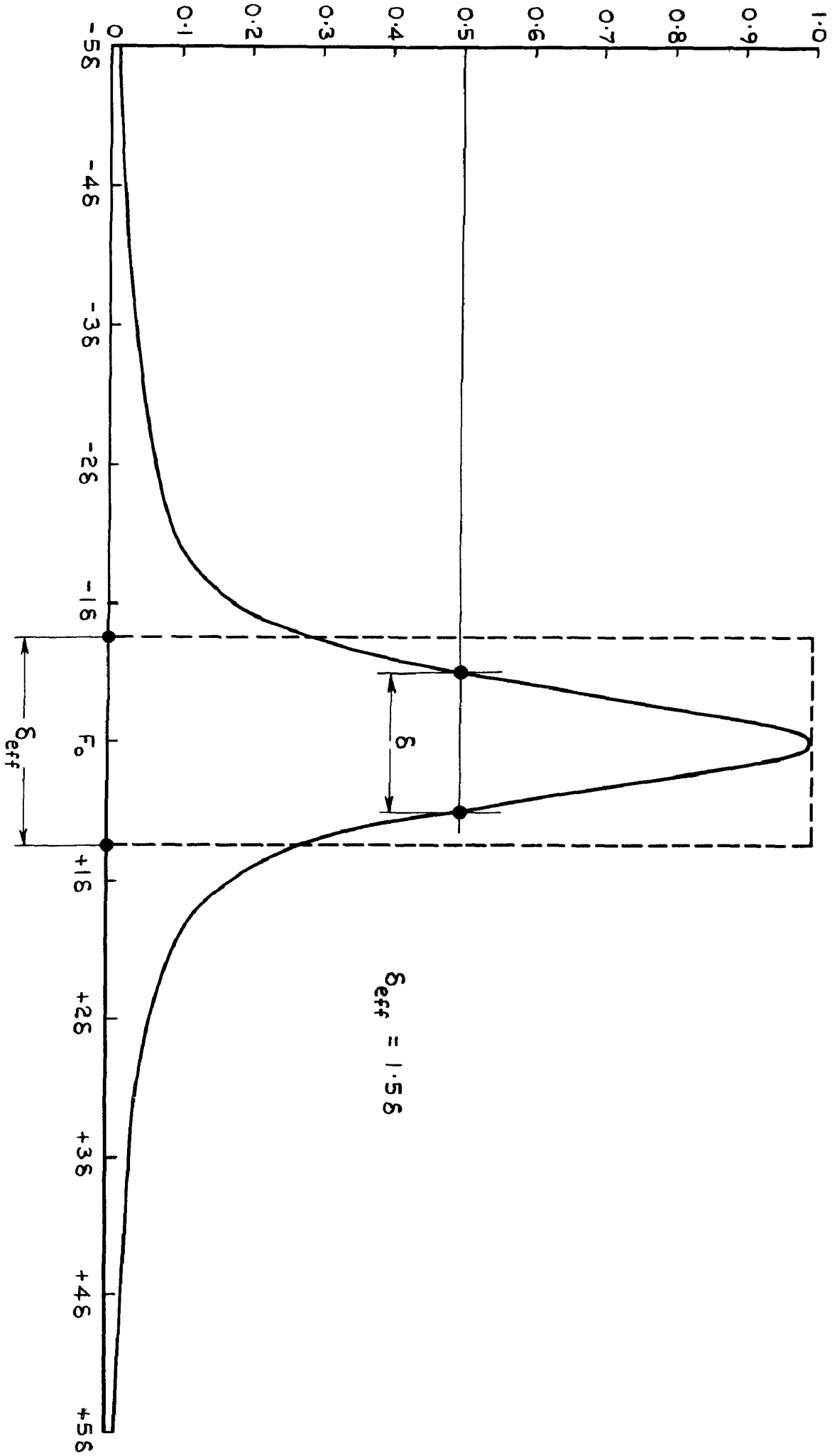

FIG. 9. SQUARED FREQUENCY RESPONSE OF FILTERS.

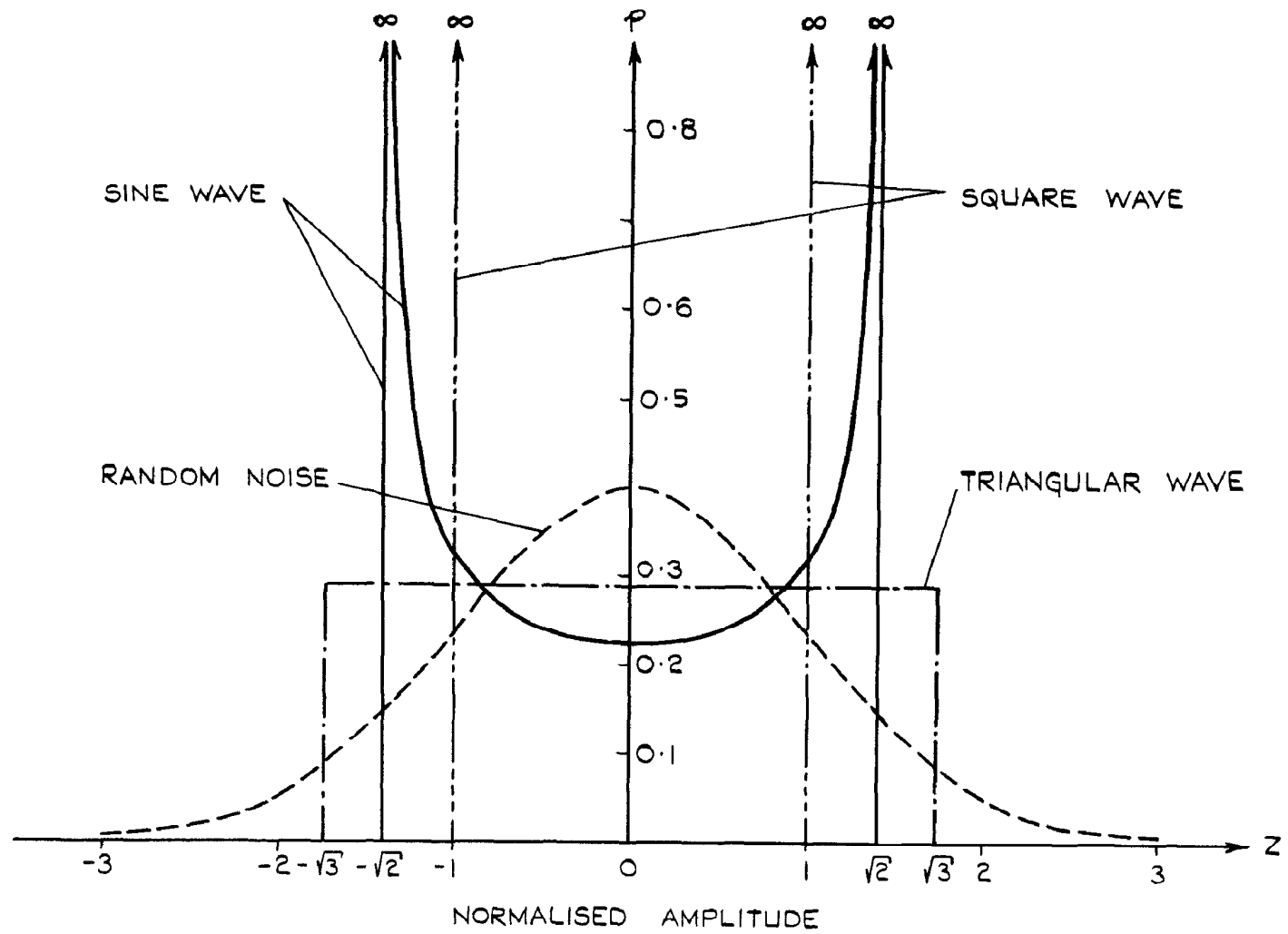
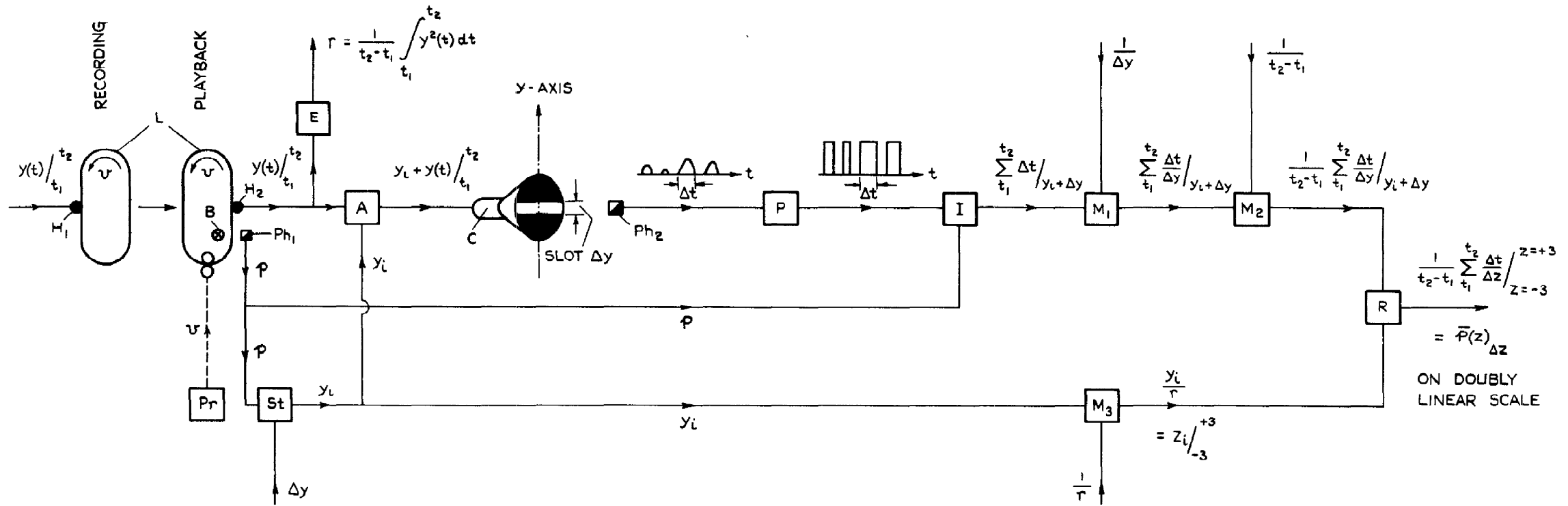

FIG. 10. AMPLITUDE DISTRIBUTIONS OF SOME ELEMENTARY TIME FUNCTIONS.



FOR KEY TO THIS FIGURE
SEE APPENDIX 6.

FIG. II. PRINCIPLE OF AMPLITUDE DISTRIBUTION ANALYSIS.

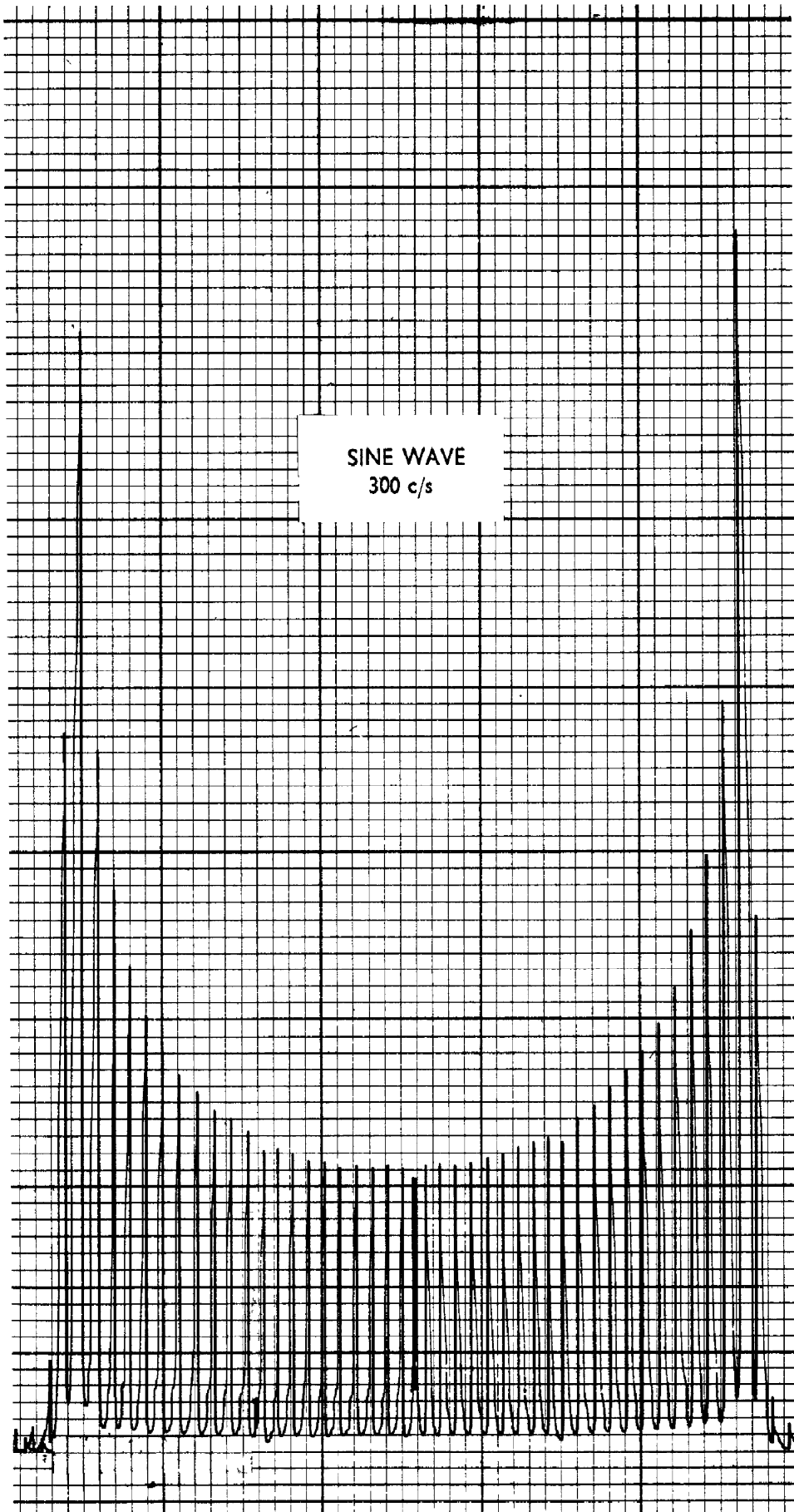

FIG.12. SPECIMEN OF ANALYSED AMPLITUDE DISTRIBUTION

----- δ - SETTINGS OF SPADA

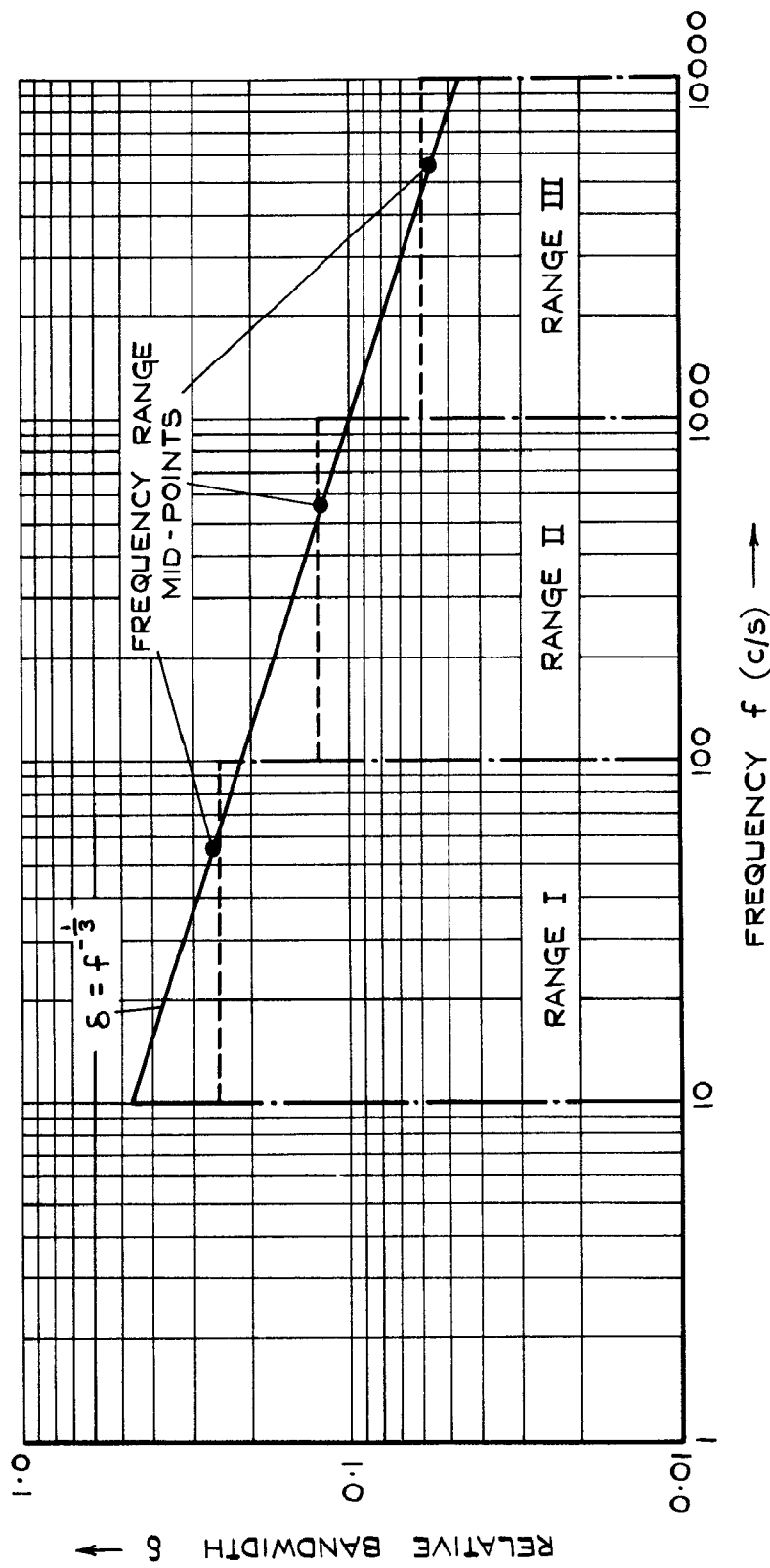

FIG. 14. RECOMMENDED FILTER BANDWIDTH FOR ANALYSIS.

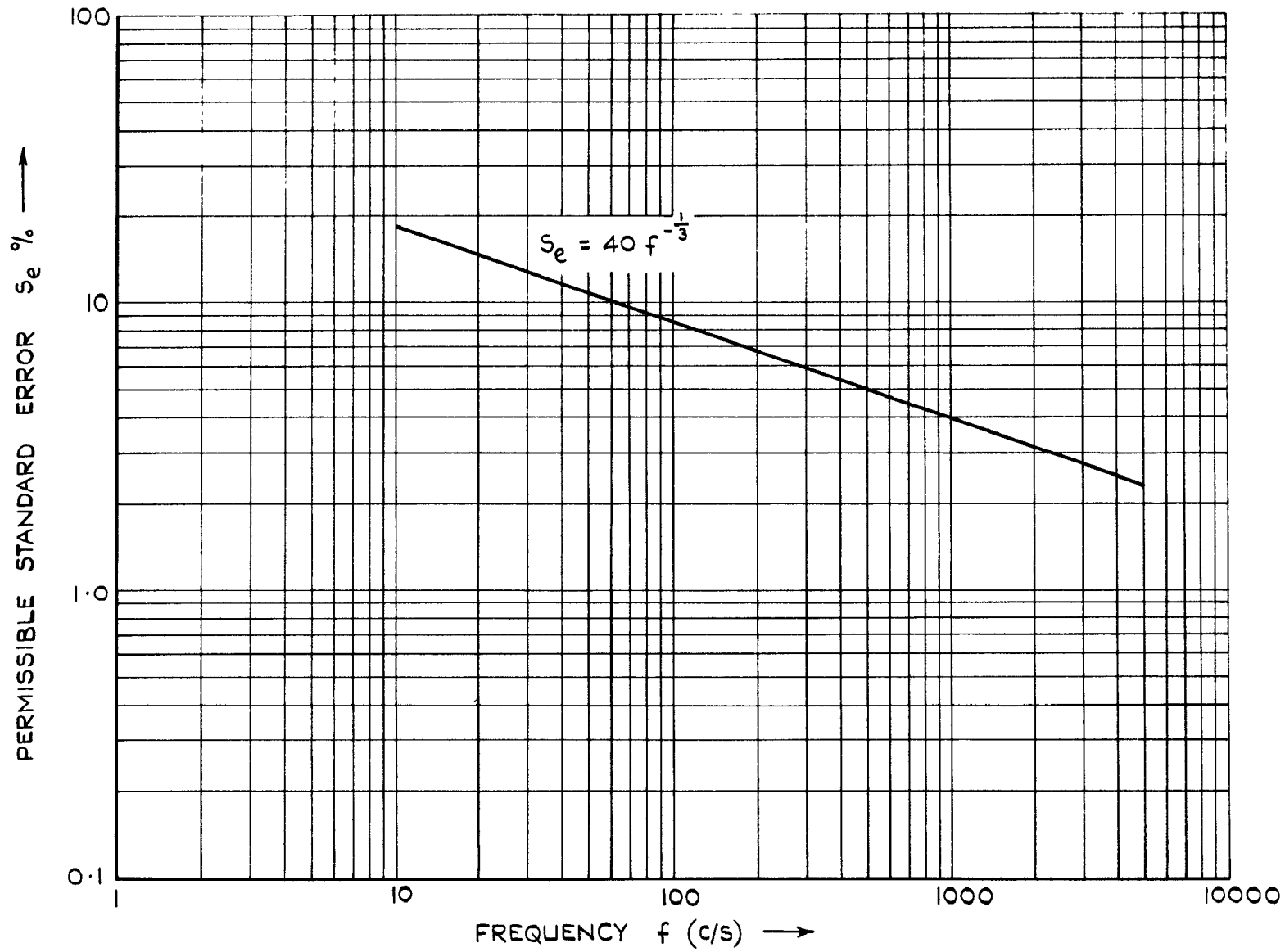

FIG. 15. MAXIMUM PERMISSIBLE STANDARD ERROR FOR ANALYSIS OF SPECTRAL DENSITY OF RECORDED VIBRATION.

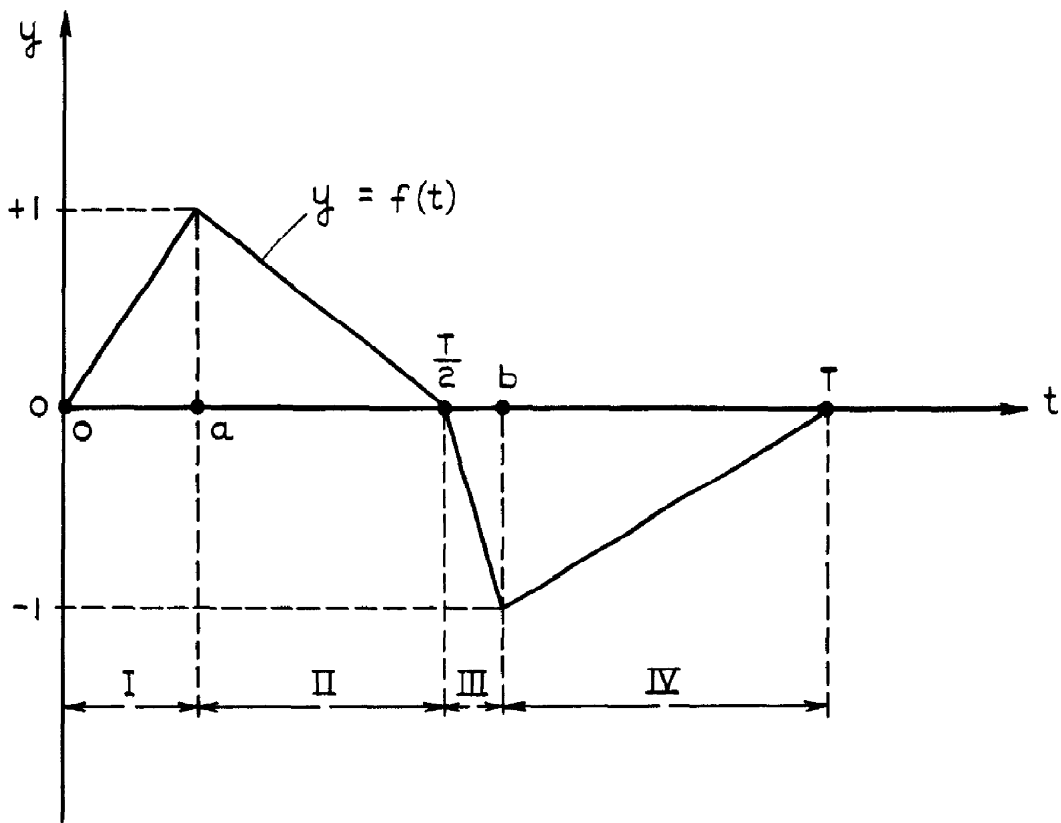

FIG. 16 (a) TRIANGULAR WAVE.

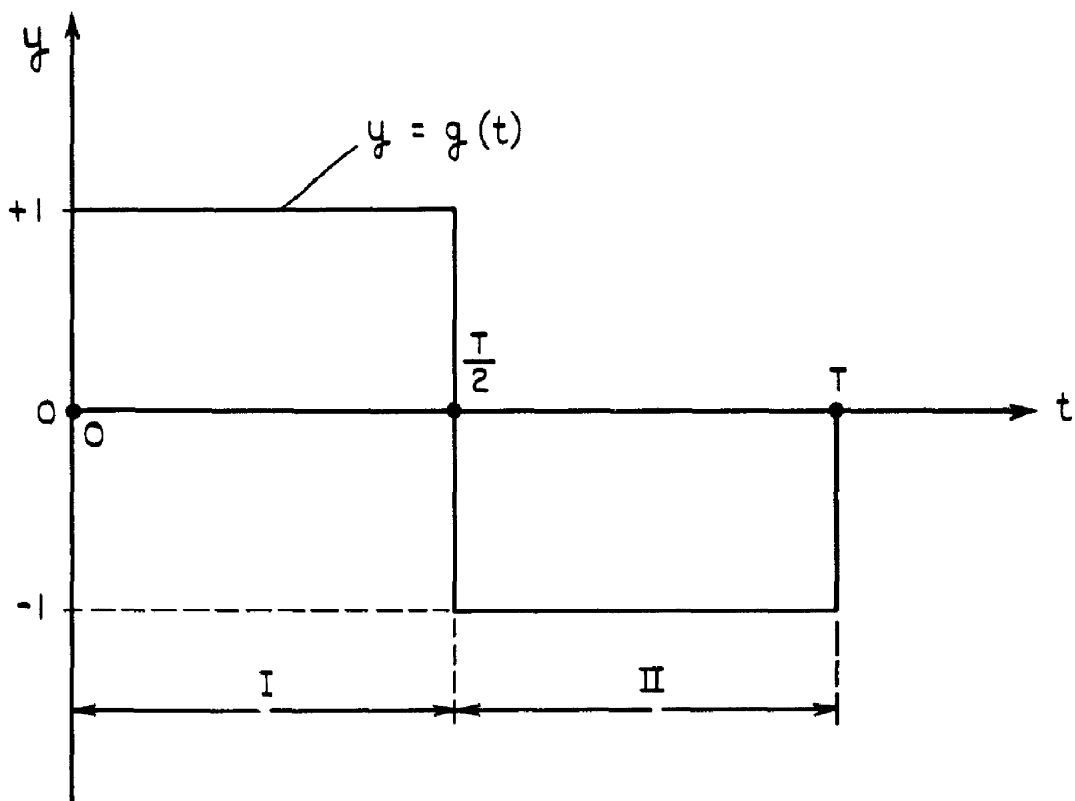

FIG. 16 (b) SQUARE WAVE.

A.R.C. C.P. No.570

THE ANALYSIS OF COMPLEX VIBRATIONS WITH SPADA.
Entres, S.L. June, 1960

534.15 :
681,3,02# :
5,001,58 :
623,451-519

This Note is concerned with a machine, known as SPADA, which has been designed for the purpose of analysing recorded G.W. vibrations. The theory underlying concepts such as frequency and amplitude distribution may be found scattered in the appropriate text-books or the relevant technical literature, but the absence of a comprehensive account dealing with the application of some of these theories to the analysis of recorded vibrations has led to widely diverging approaches. In describing the functioning of SPADA it is necessary to state in applied form some elementary concepts relevant to the analysis; particularly the spectral density, the probability distribution of amplitude and the sampling error are discussed. SPADA will be used both as a research instrument and as a facility available for the analysis of vibrations recorded by the G.W. industry and other establishments. Its use, however, is not restricted to vibration analysis. SPADA will, within its limitations, analyse any parameter which can be recorded on magnetic tape.

A.R.C. C.P. No.570

THE ANALYSIS OF COMPLEX VIBRATIONS WITH SPADA.
Entres, S.L. June, 1960.

534.15 :
681,3,02# :
5,001,58 :
623,451-519

This Note is concerned with a machine, known as SPADA, which has been designed for the purpose of analysing recorded G.W. vibrations. The theory underlying concepts such as frequency and amplitude distribution may be found scattered in the appropriate text-books or the relevant technical literature, but the absence of a comprehensive account dealing with the application of some of these theories to the analysis of recorded vibrations has led to widely diverging approaches. In describing the functioning of SPADA it is necessary to state in applied form some elementary concepts relevant to the analysis; particularly the spectral density, the probability distribution of amplitude and the sampling error are discussed. SPADA will be used both as a research instrument and as a facility available for the analysis of vibrations recorded by the G.W. industry and other establishments. Its use, however, is not restricted to vibration analysis. SPADA will, within its limitations, analyse any parameter which can be recorded on magnetic tape.

© *Crown Copyright 1961*

Published by

HER MAJESTY'S STATIONERY OFFICE

To be purchased from

York House, Kingsway, London W.C.2

423 Oxford Street, London W.1

13A Castle Street, Edinburgh 2

109 St. Mary Street, Cardiff

39 King Street, Manchester 2

50 Fairfax Street, Bristol 1

2 Edmund Street, Birmingham 3

80 Chichester Street, Belfast 1

or through any bookseller

Printed in England