

C.P. No. 421  
(19,928)  
A.R.C. Technical Report

C.P. No. 421  
(19,928)  
A.R.C. Technical Report



MINISTRY OF SUPPLY

AERONAUTICAL RESEARCH COUNCIL

CURRENT PAPERS

A Simple Method of Improving  
the Supersonic Velocity Distribution in a  
Transonic Tunnel having Slotted Walls

by

*C. N. Hall*

LONDON: HER MAJESTY'S STATIONERY OFFICE

1959

TWO SHILLINGS NET



ADDENDUM

Reference is made in paragraph 2 of Section 4.2 to a television camera. This is part of one of two closed circuit television systems used for viewing the model from the observation room.

---



U.D.C. No. 533.6.011.35: 533.6.071.1

Technical Note No. Aero 2517

July, 1957

ROYAL AIRCRAFT ESTABLISHMENT

A simple method of improving the supersonic velocity distribution  
in a transonic tunnel having slotted walls

by

C.N. Hall

---

SUMMARY

This note describes how the centre-line distribution of Mach number in the R.A.E. 8 ft x 6 ft Transonic Tunnel has been modified at supersonic speeds by means of curved lengths of perforated steel plate set behind a proportion of the suction slots in the walls of the working section. It was found that the slope and curvature of the perforated strips and the distance from the suction slots determined their effect on the distribution of Mach number. A form of plate was evolved which reduced the variation of Mach number about the mean from  $\pm 0.010$  to  $\pm 0.006$  at the maximum Mach number.

---

## LIST OF CONTENTS

	<u>Page</u>
1 Introduction	3
2 The working section of the 8 ft x 6 ft Transonic Tunnel	3
3 The calibration technique	3
4 Mach number distributions on the centre-line of the working section	3
4.1 The initial centre-line distributions	3
4.2 The use of perforated plates to improve the flow distributions	4
4.3 The improved centre-line distributions	5
5 The design of plates to achieve a required effect	5

## LIST OF ILLUSTRATIONS

	<u>Figure</u>
The centre-line static tube in the R.A.E. 8 ft x 6 ft Transonic Tunnel	1
Details of the working section, the mounting of a perforated plate and the sting support used in the R.A.E. 8 ft x 6 ft Transonic Tunnel	2
Centre-line distribution of maximum Mach number. Roof and floor diverged ( $\Gamma = + 0.45^\circ$ ) Plates A & B	3
Centre-line distributions of Mach number. Roof and floor diverged ( $\Gamma = + 0.45^\circ$ ) Plates C & D, E & F	4
Optimum centre-line distributions of Mach number before and after modification by means of perforated plates	5
Change in Mach number at the centre-line due to perforated plates of different shapes	6

## 1 Introduction

The R.A.E. 10 ft x 7 ft High Speed Tunnel was converted to transonic operation during 1955, and was officially reopened in April 1956 as the R.A.E. 8 ft x 6 ft Transonic Tunnel. Examination of the velocity distribution on the centre-line of the working section showed that at wind speeds above  $M = 1.10$  variations of Mach number within the test section increased to undesirable proportions. Many models to be tested in the tunnel will be of such a length that, at all but the highest Mach numbers, the wall reflections of disturbances due to the model will strike the model again further downstream. This will exclude an intermediate range of test Mach numbers, and efforts were therefore made to improve the velocity distributions so that tests made at higher speeds will be reliable.

This note describes a successful method of improving the velocity distributions by means of curved lengths of perforated steel plate set behind the suction slots of the working section. The method was evolved during a series of tests in May and June 1956.

## 2 The working section of the 8 ft x 6 ft Transonic Tunnel

The auxiliary suction which is required to achieve Mach numbers greater than  $M = 0.85$  is applied to the working section through 24 slots which provide an open area ratio of 11%. The slots start with zero width at -1 ft 2 in.\*, expanding to reach their full width at 6 ft 10 in., and run at constant width from here to 15 ft. The side walls of the working section are parallel, but the roof and floor can be adjusted over a small range of divergence angle (divergence angle =  $\Gamma$ , slope of roof or floor; maximum slope =  $\pm 0.45^\circ$ ). The supporting sting for models is mounted on two vertical lead screws set in a pairing that spans the tunnel from roof to floor (Figs. 1 and 2c).

## 3 The calibration technique

A tube 3.41 inches in diameter and  $27\frac{1}{2}$  foot long, with static pressure tappings along each side, was used to measure the velocity distributions along the centre-line of the working section. It was carried at its rear end by the support rig, and its forward end projected into the contraction where it was supported by cables (Fig. 1). The pressure tappings were at 1 foot intervals from -13 ft to -4 ft, at 6 inch intervals to -1 ft, at 3 inch intervals to +7 ft, and at 2 inch intervals to 11 ft 8 in. on the port side, and at 1 foot intervals along the starboard side.

The Mach number distributions were measured at a Reynolds number of 1.8 million/foot. The measured pressures were converted to Mach number by reference to the total head as measured by a static pressure tapping in the settling chamber; the largest difference between this observed value and the actual total head in the working section is -0.4% (at  $M = 1.0$ ), which corresponds to an error in Mach number of -0.004.

## 4 Mach number distributions on the centre-line of the working section

### 4.1 The initial centre-line distributions

With the roof and floor parallel the variation of Mach number in the test section was within  $\pm 0.003$  up to  $M = 1.10$  (Fig. 5 full lines),

---

\* Longitudinal position in the working section is measured downwind relative to a constructional datum (the start of the original 10 ft x 7 ft working section). The model C.G. position, at zero incidence, relevant to these tests was at 9 ft 1 in.

but when the suction quantity and roof and floor divergence were increased to obtain the highest test Mach numbers the rate of expansion of the flow became too great, causing undesirable pressure gradients in the test section. The deceleration aft of 11 ft was due to the support rig, and was not nearly so marked at a distance of 9 inches to one side of the centre-line. However, at subsonic speeds, this deceleration started at 10 ft 6 ins. and determined the rearward limit of the test section.

#### 4.2 The use of perforated plates to improve the flow distributions

It was thought that the distribution of suction along the slots, and hence the rate of development of the flow, could be modified by placing lengths of perforated sheet steel behind the slots. These were made up from 8 ft x 6 in. strips of 18 s.w.g. mild steel plate perforated with 0.069 inch diameter holes at the rate of 105 holes/sq.in., i.e. an open area ratio of 39%, and they were mounted to fit between the stiffening flanges of the beams that form the working section walls (Fig. 2b).

The perforated plates were first placed hard up against the tapered portion of twelve of the slots (Plates A, Fig. 3) the curve in the downwind end of the plates being intended to soften any disturbance shed by the ends of the plates. The plates succeeded in reducing the rate of expansion of the flow, but worsened the distribution in the test section at maximum Mach number. Putting the plates behind the parallel portion of the slots, with the curved ends upwind (Plates B, Fig. 3) reduced the general level of Mach number in the test section, but the distribution was still very uneven. The compression ending at 9 ft 9 ins. was found to be caused by the television camera which had been placed close behind a slot, at 8 ft, and it was therefore moved to 10 ft and drawn back 2 inches from the slot. The compression ending at 7 ft 2 ins., however, seemed to be connected with the curvature of the upwind ends of the plates.

Tests were then made with these plates set in various positions in relation to the slots (Plates C and D, Fig. 4a). Since Plates B were obviously too gross in their effects, the number of plates was reduced from twelve to eight, and they were moved out, away from the slots. This allows the air flowing out of the slots to expand into the 6 inch passage between the flanges before encountering the perforated plates so that the pressure drop across the plates is reduced, and, if the plates are moved out more than  $2\frac{1}{2}$  inches from the slots, lightening holes in the flanges start to be uncovered with the result that the air can by-pass the perforated plates. These tests established that both the slope and curvature of the perforated strips as well as their distance from the slots are major factors in determining the effect of the strips on the distribution of Mach number. This effect is transmitted to the centre-line at approximately the Mach angle,  $\tan^{-1}\sqrt{M^2 - 1}$ , and vanishes at test Mach numbers below  $M = 1.0$ . Curves have been added to Fig. 4a to show the rearward movement along the centre-line, with increasing Mach number, of disturbances originating at  $4\frac{1}{2}$  ft and at  $6\frac{1}{2}$  ft on the wall; the curves are based on the assumption that the disturbances will be propagated at the Mach angle, and a mean distance from wall to centre-line of  $5\frac{1}{2}$  ft has been used, i.e. the rearward movement of the disturbance is  $3\frac{1}{2}\sqrt{M^2 - 1}$  ft. It will be seen that the curved lead-in to the plates cause a local reduction in Mach number, the reduction lessening as the plates curve back to become parallel to the slots; in the case of Plates D the entry curvature is further from the slot and therefore much less powerful, but the continuing slope of the plates aft of 6 ft 6 ins. causes a slight reduction of Mach number right on to the rear of the test section.

These observations were used as outlined in Section 5 to devise Plates E and F (Fig. 4b). By curving away into an expansion aft of



7 ft 6 in., these plates maintained a steady velocity level in the test section from 10 ft to 11 ft at the maximum Mach number; the curvature of Plates F at 6 ft 3 in. was increased over that of Plates E in order to prevent the drop in Mach number at 9 ft that occurred previously.

The improvement in distribution at maximum Mach number was not obtained without penalty, and at a test Mach number of  $M = 1.10$ , with the roof and floor parallel, the perforated plates caused an unwanted expansion in the test section (Fig. 5). This was reduced by fully converging the roof and floor for tests at this Mach number. The distribution at  $M = 1.26$  could have been further improved to eliminate the slight compression at the downstream end of the test section, but this would have aggravated the expansion at  $M = 1.10$ , so the distribution resulting from the use of Plates F was accepted as a fair compromise, and this arrangement of plates was adopted permanently.

#### 4.3 The improved centre-line distributions

Fig. 5 compares the initial Mach number distributions with the improved distributions obtained by means of the final shape of perforated plates (Plates F, Fig. 4b). The maximum variation of Mach number on the centre-line of the test section has been reduced from  $\pm 0.010$  to  $\pm 0.006$ . If the test section is considered to extend from 8 ft to 11 ft the improvement is even more marked at the higher Mach numbers ( $\pm 0.012$  reduced to  $\pm 0.005$ ), but at subsonic speeds the increase of pressure caused by the support rig limits the rear of the test section to 10 ft 6 ins. For this reason the support rig has now been moved back 2 feet, the model C.G. position moving back 7 inches to 9 ft 8 in.; this change has extended the test section length by about 18 inches.

#### 5 The design of plates to achieve a required effect

The perforated steel plates were used in the first instance as a simple means of altering the distribution of suction along the working section. However, it was soon evident that other factors had important effects upon the velocity distribution within the test section, notably the local slope and curvature of the perforated plates, and the distance of the plates from the surface of the slotted walls. Although the interplay of these parameters was not at all clear in the early stages, alterations to the perforated plates became progressively more systematic as evidence was collected on the way in which they worked.

Fig. 6 shows the changes in Mach number at the centre-line caused by Plates C, D, E and F behind 8 of the 24 wall slots. The origins of longitudinal axes have been displaced by  $\frac{3}{2}\sqrt{M^2 - 1}$ , corresponding to the longitudinal distance between the origin of a disturbance at the wall, and the point at which the disturbance reaches the centre-line when it is propagated at the Mach angle. Thus, corresponding points on the wall and the centre-line are vertically in line in the diagram. Qualitatively, the changes in Mach number caused by the plates are as would be expected near a solid two-dimensional profile of the same shape in an unbounded supersonic flow, with the change from compression to expansion occurring at the point of inflection in the perforated plate. Quantitatively, the effect of a given plate can be increased by moving it nearer to the suction slot.

Bearing in mind the influence that these parameters have on the centre-line Mach number, it is possible to arrive at a design of plate which has the required effect on a Mach number distribution after only one or two attempts. In deciding upon the best form of plate for a particular slotted transonic

tunnel, the choice will in general be a compromise between the differing needs at different Mach numbers. In this connection, the importance of the higher transonic Mach numbers, as mentioned in Section 1, should be remembered.

---

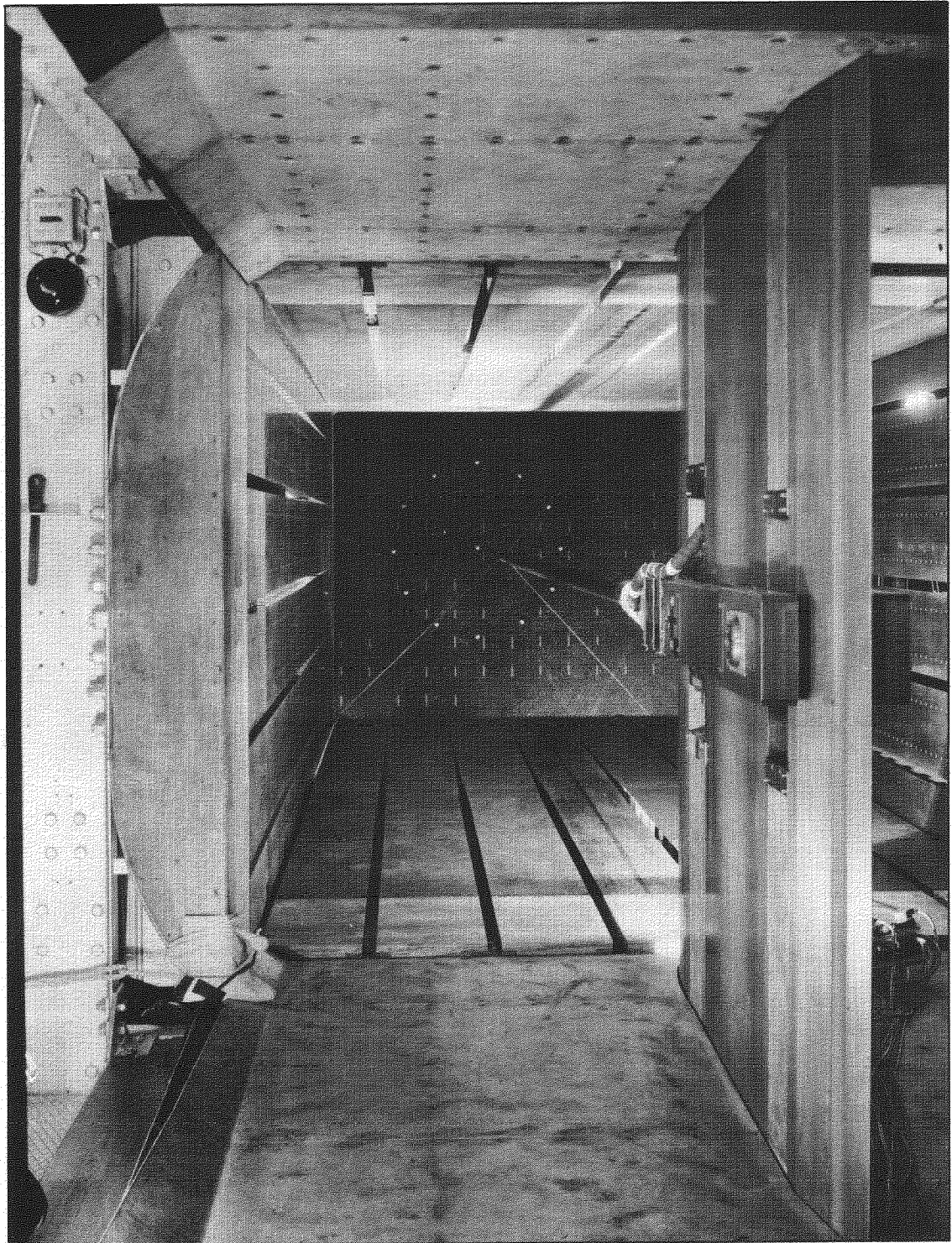
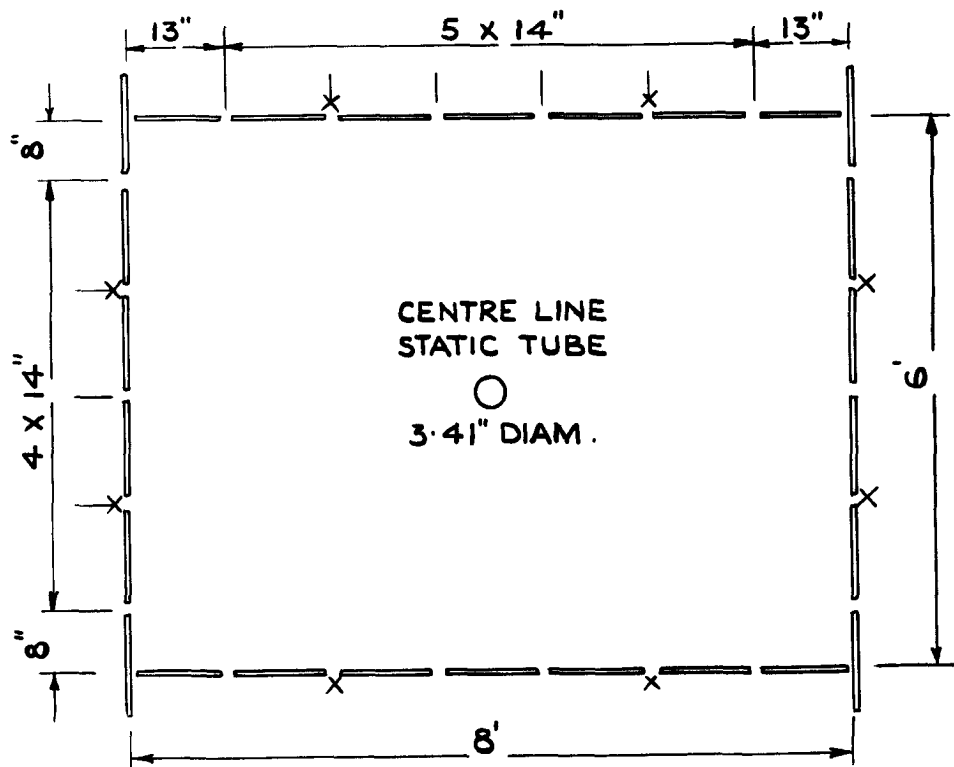
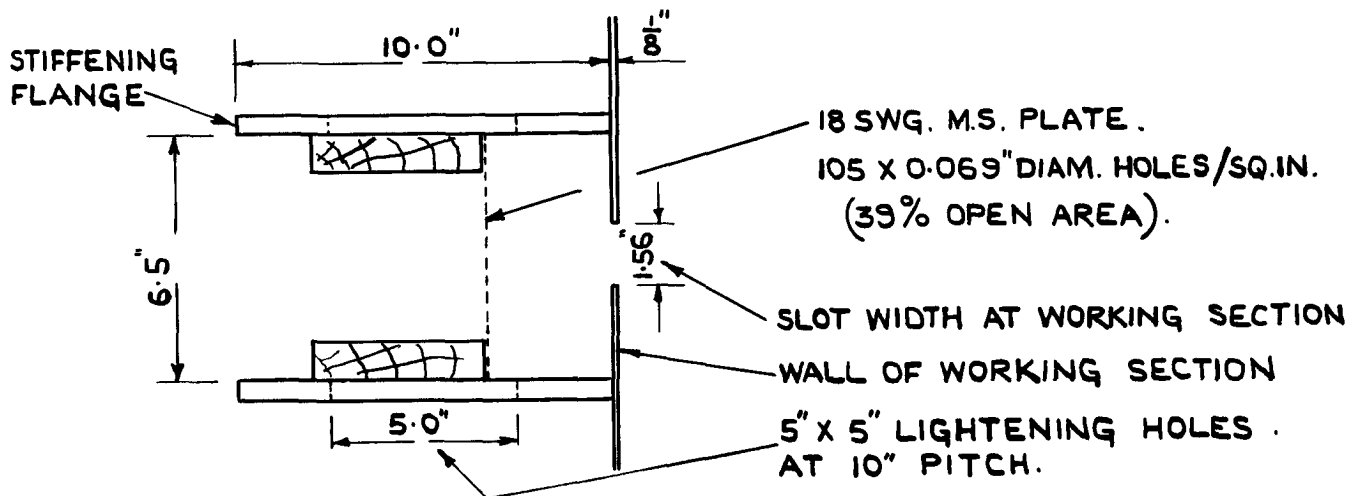

FIG.1. THE CENTRE-LINE STATIC TUBE IN THE R.A.E.  
8 FT. X 6 FT. TRANSONIC TUNNEL



OPEN AREA RATIO = 11%, X INDICATES SLOTS BEHIND WHICH THE 8 PERFORATED PLATES WERE SET.

(a). WORKING SECTION.



(b). DETAIL OF THE MOUNTING OF A PERFORATED PLATE.

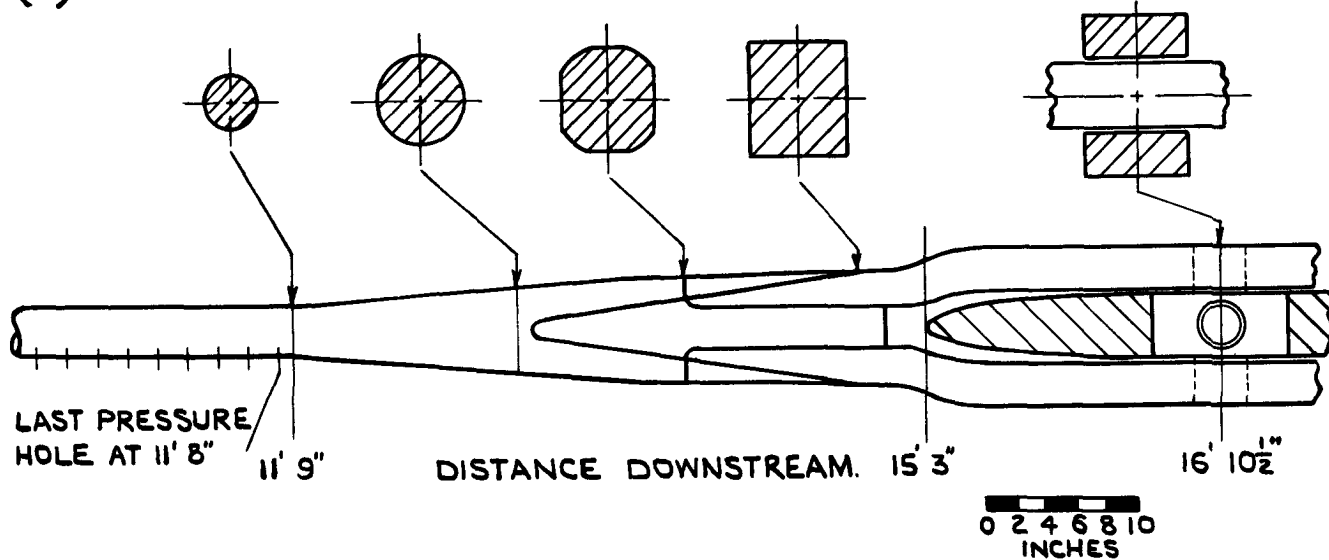

(c). STING SUPPORT (PLAN VIEW) AS USED UP TO MARCH 1957.

FIG.2 (a-c). DETAILS OF THE WORKING SECTION, THE MOUNTING OF A PERFORATED PLATE AND THE STING SUPPORT IN THE R.A.E. 8FT. X 6FT. TRANSONIC TUNNEL.

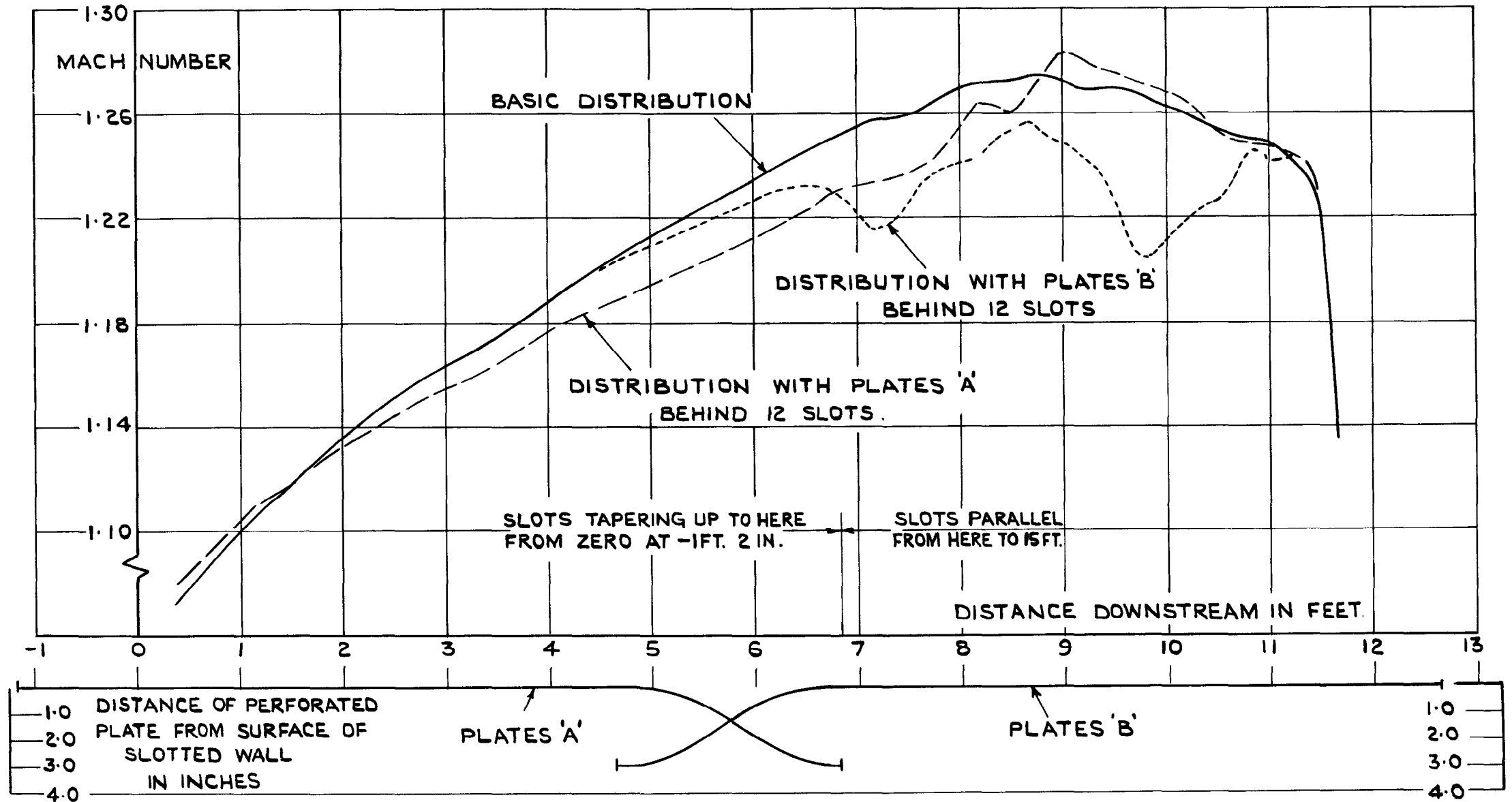

**FIG.3. CENTRE-LINE DISTRIBUTION OF MAXIMUM MACH NUMBER.**  
 ROOF & FLOOR DIVERGED ( $\Gamma = +0.45^\circ$ ) PLATES A & B.

— BASIC DISTRIBUTION.  
 - - - DISTRIBUTION WITH PLATES 'C' BEHIND 8 SLOTS  
 - - - DISTRIBUTION WITH PLATES 'D' BEHIND 8 SLOTS

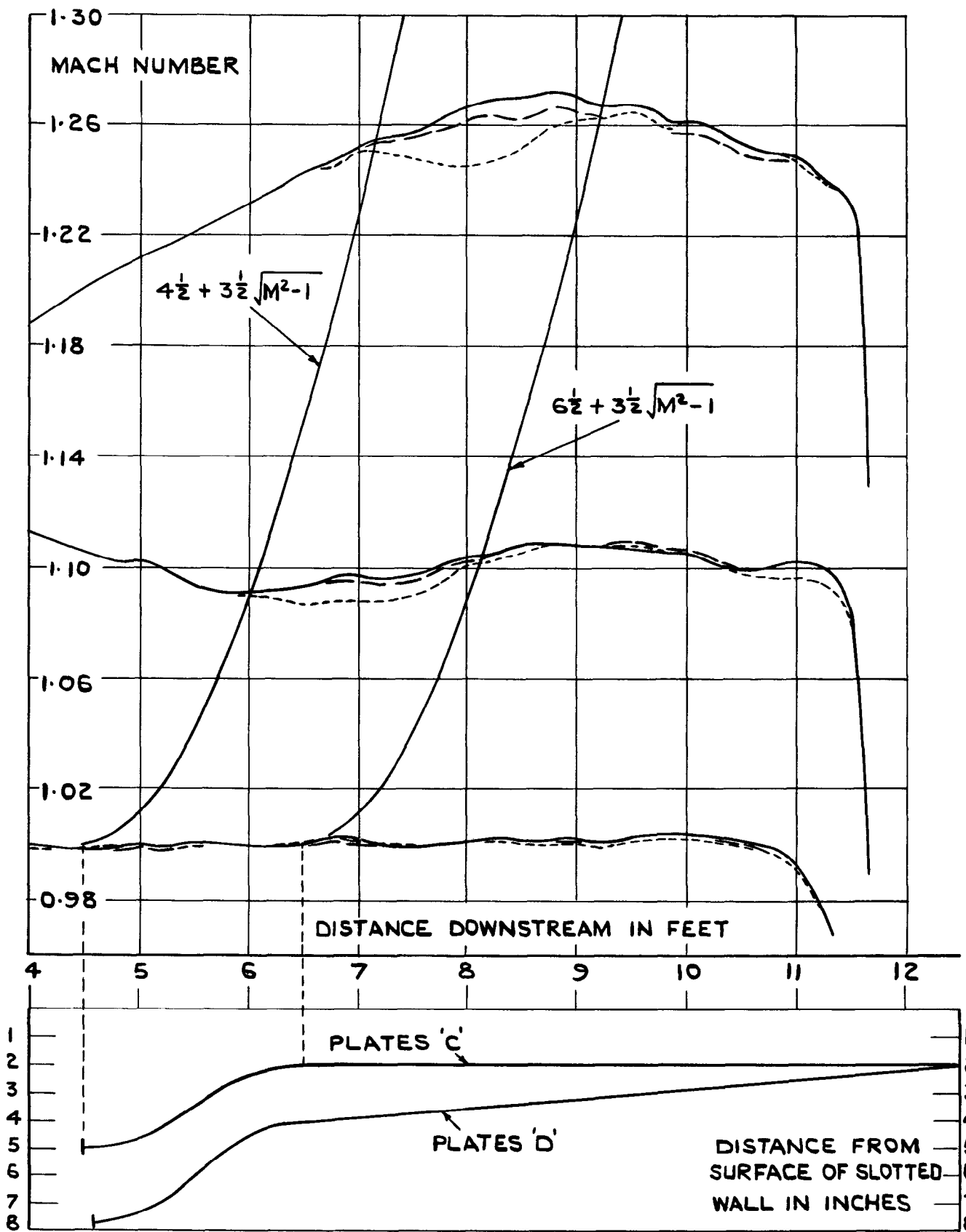

FIG 4 a. CENTRE-LINE DISTRIBUTIONS OF MACH NUMBER. ROOF & FLOOR DIVERGED ( $\Gamma = +0.45^\circ$ ) PLATES C & D.

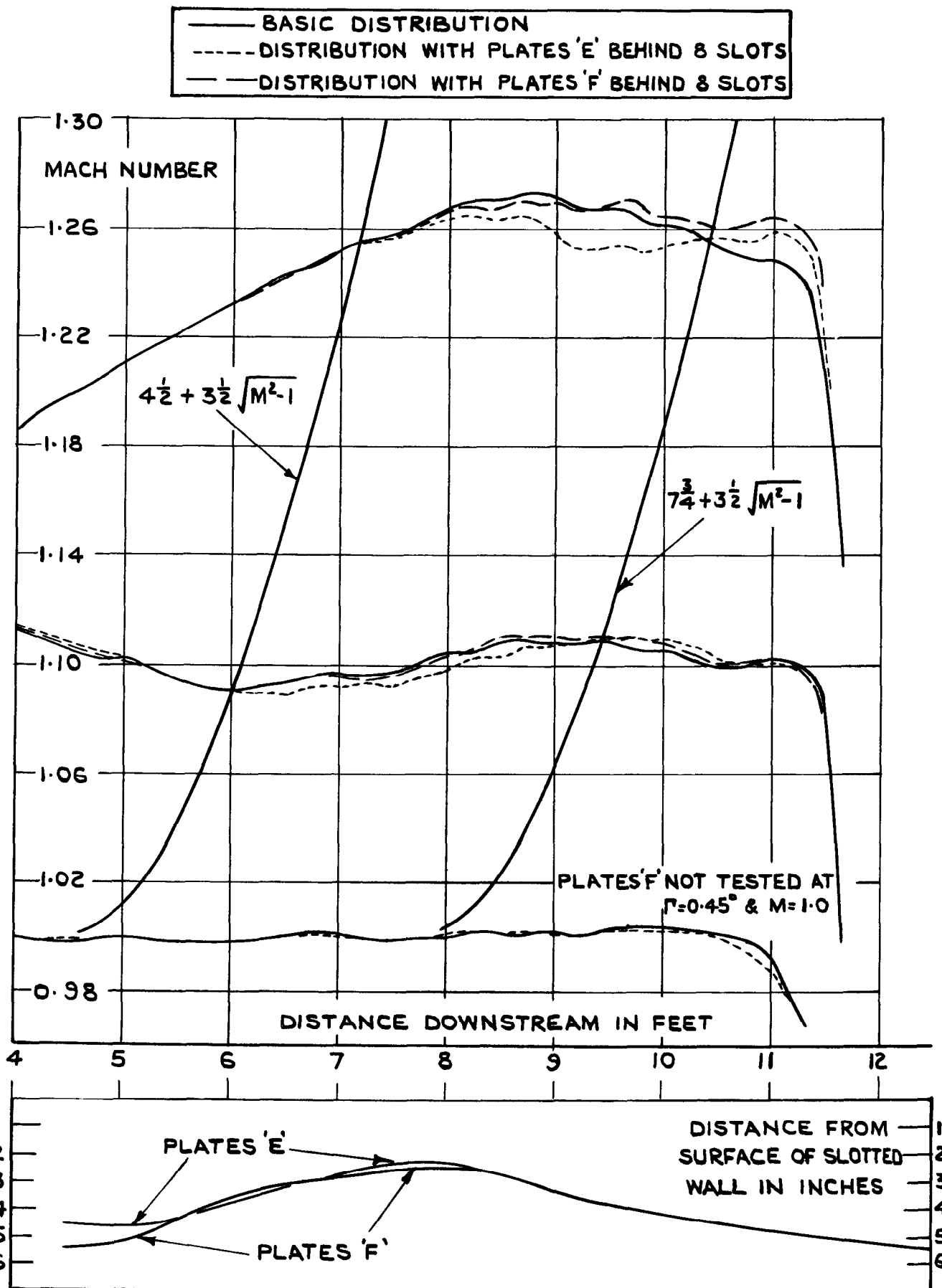

FIG.4b. CENTRE-LINE DISTRIBUTIONS OF MACH NUMBER. ROOF & FLOOR DIVERGED ( $\Gamma = +0.45^\circ$ ) PLATES E & F.

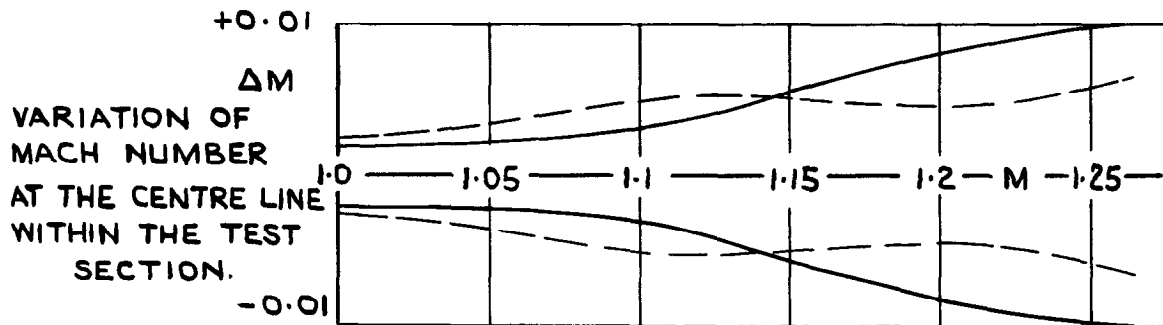
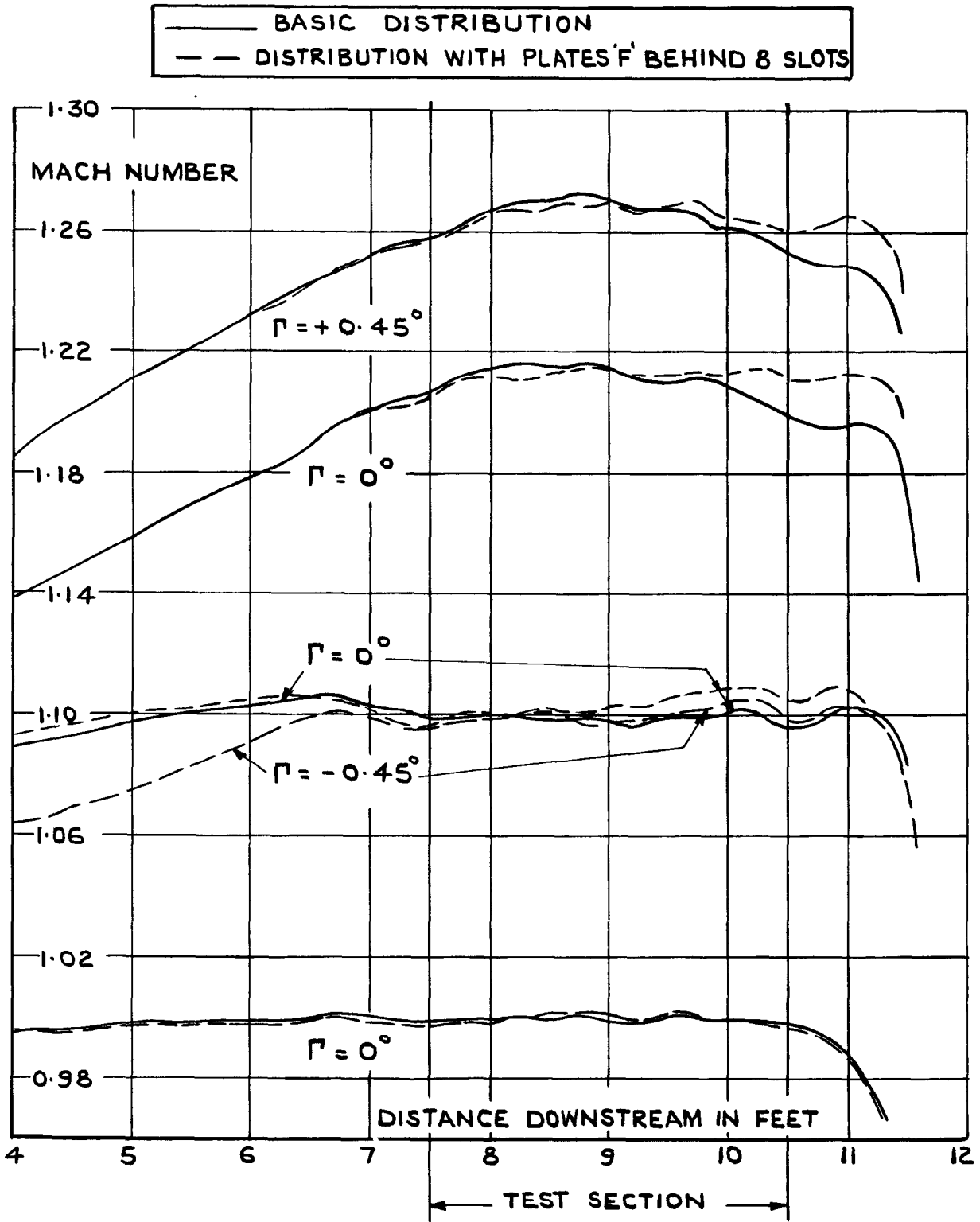

FIG. 5. OPTIMUM CENTRE-LINE DISTRIBUTIONS OF MACH NUMBER BEFORE AND AFTER MODIFICATION BY MEANS OF PERFORATED PLATES.



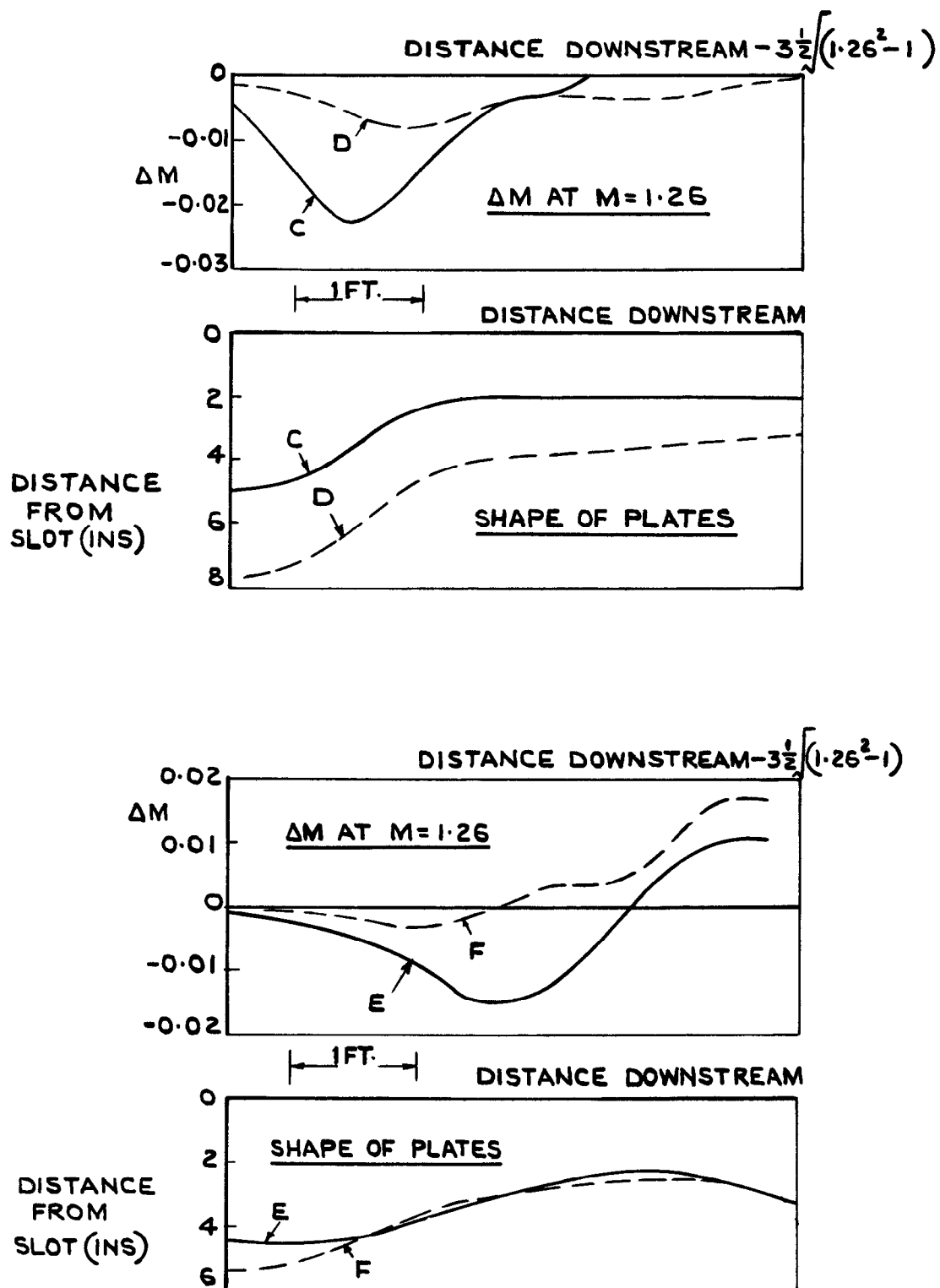

FIG 6. CHANGE IN MACH NUMBER AT THE CENTRE-LINE DUE TO PERFORATED PLATES OF DIFFERENT SHAPES.





© *Crown Copyright 1959*

Published by  
HER MAJESTY'S STATIONERY OFFICE

To be purchased from  
York House, Kingsway, London w.c.2  
423 Oxford Street, London w.1  
13A Castle Street, Edinburgh 2  
109 St. Mary Street, Cardiff  
39 King Street, Manchester 2  
Tower Lane, Bristol 1  
2 Edmund Street, Birmingham 3  
80 Chichester Street, Belfast  
or through any bookseller

*Printed in Great Britain*