

N.A.R.

R. & M. No. 2758
(12,990)
A.R.C. Technical Report

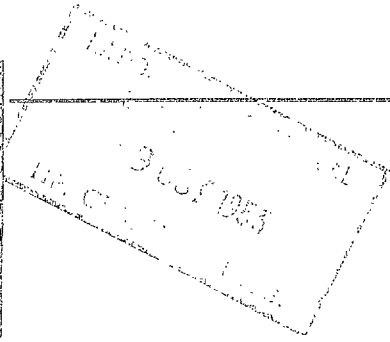

MINISTRY OF SUPPLY

AERONAUTICAL RESEARCH COUNCIL
REPORTS AND MEMORANDA

Elasticity of a Sheet Reinforced by Stringers
and Skew Ribs, with Applications to
Swept Wings

By

E. H. MANSFIELD, M.A.

Crown Copyright Reserved

LONDON: HER MAJESTY'S STATIONERY OFFICE

1953

PRICE 7s 6d NET

Elasticity of a Sheet Reinforced by Stringers and Skew Ribs, with Applications to Swept Wings

By

E. H. MANSFIELD, M.A.

COMMUNICATED BY THE PRINCIPAL DIRECTOR OF SCIENTIFIC RESEARCH (AIR),
MINISTRY OF SUPPLY

*Reports and Memoranda No. 2758**

December, 1949

Summary.—A rigorous theory has been developed for determining the stresses and displacements in a sheet reinforced by stringers and ribs which are not at right-angles to the stringers. The solution of many problems of practical importance has been facilitated by the introduction of a stress function.

The theory has been applied to a cylinder of rectangular section stiffened with such skew ribs (a simplified representation of a swept wing). It is shown that there are axes about which applied moments produce pure twist or pure curvature of the cylinder. There are simple formulae for determining these axes and the relationships between twist and curvature and the applied moments.

1. *Introduction.*—The analysis of the elastic behaviour of an unswept wing is comparatively simple in so far as the ribs are at right-angles to the stringers. But the use of swept wings in aircraft has introduced a variety of structural problems. If there are ribs parallel to the direction of flight they will not be at right-angles to the stringers and so there will be a measure of skewness in the structural geometry of the wing. For instance, in calculating the deformation of wings due to 'simple bending' loads (*i.e.*, loads which would cause ordinary bending deflections if the ribs were normal to the spars) the resistance of the ribs to flexure of the wing must be considered. Because of the skewness, or asymmetry, of the wing this resistance of the ribs to simple flexure of the wing will introduce shearing forces in the top and bottom surfaces of the wing, and these in turn will cause the wing to twist. Similarly when a torque is applied to the wing the presence of ribs not at right-angles to the stringers (hereafter called skew ribs) introduces a component of flexure in the resultant deformation.

Wittrick³ produced a theory for the behaviour of swept wings. A thin-walled cylinder of arbitrary section was considered and the assumption was made that the ribs were closely spaced and completely rigid in their own plane. Wittrick pointed out that the validity of this assumption is open to doubt, as the high flexural rigidity required from aero-elastic considerations and the smooth surface required for aerodynamic reasons tends to influence the design in the direction of a very thick skin with consequently few ribs.

The present report considers the stiffness as well as the skewness of the ribs but due to the added degree of complexity attention has been concentrated on elementary types of structure and loading.

It is shown that for a cylinder of rectangular section stiffened with skew ribs there are axes about which applied moments produce pure twist or pure curvature. There are simple formulae for determining these axes (which are not in general at right-angles) and the torsional and flexural stiffnesses.

* R.A.E. Report Structures 52, received 7th March, 1950.

2. *Method of Solution.*—In a panel stiffened with stringers and ribs at right-angles to the stringers it has been customary to simplify stress analysis by assuming

- (a) the stiffening effect of the discrete stringers will not be seriously altered by spreading them out, *i.e.*, the stringers can be adequately represented by an elastic sheet with equivalent, average, uni-directional properties, and
- (b) all out-of-balance forces necessary to prevent any strains in a direction parallel to the ribs may be neglected.

Of these two assumptions (b) would appear to be less justifiable than (a). But in fact it works quite well because the loads applied to the panel are either simple shearing loads, in which case there are no strains parallel to the ribs and, therefore, no out-of-balance forces, or the loads are applied parallel to the stringers, in which case the normal out-of-balance forces are of secondary importance* (R. & M. 2648⁴).

However, for a swept panel assumption (b) is untenable for both the main types of loading mentioned above would produce appreciable strains in the direction of the skew ribs if these ribs were removed—another way of saying that the presence of skew ribs will modify the stress distribution in the panel to a much greater extent than ribs at right angles to the stringers.

Accordingly the only assumption made here regarding the ribs is that they may be treated in the same way as stringers are treated and represented by an elastic sheet with equivalent unidirectional properties.

It should be pointed out that the type of distortion of the ribs considered here is that of bending in their own plane, so that, for example, if a rib in a cylinder of rectangular section consisted of a rectangular sheet of thickness t' and height $2h$ then the I of the rib would be $2/3(h^3t')$ and hence the effective section area of the rib will be $ht'/3$. And if the rib pitch were ϕ , say, the thickness of the equivalent sheet would be $ht'/3\phi$.

2.1. *Assumptions.*—Apart from the representation of stringers and ribs as equivalent elastic sheets the following assumptions are also made:

- (a) Stress-strain relations are linear.
- (b) Buckling does not take place.
- (c) The actual sheet (as opposed to the superposed equivalent sheets) is homogeneous and isotropic.
- (d) The ribs are unable to offer any resistance to warping out of their plane.
- (e) The equivalent elastic sheets have constant properties in so far as the stringer area and pitch and the effective rib area and pitch do not vary.

2.2. *Derivation of the Basic Equations.*—The distribution of strain in the sheet and in the X- and Y-members is completely determined by the displacements u and v .

The strain in the stringers and the strain in the sheet in the x -direction is $\partial u/\partial x$; the strain in the y -direction is $\partial v/\partial y$; the shear strain is $(\partial u/\partial y + \partial v/\partial x)$ and the strain in the Y-members is given by

$$\frac{\partial V}{\partial Y} = s^2 \frac{\partial u}{\partial x} + c^2 \frac{\partial v}{\partial y} + sc \left(\frac{\partial u}{\partial y} + \frac{\partial v}{\partial x} \right) \dots \dots \dots (1)$$

* We should expect this since such forces can only be due to the small Poisson ratio effect, or to the rate of change of shear stress in the sheet.

where s and c have been introduced as abbreviations for $\sin \eta$ and $\cos \eta$. The stress-strain relations for the sheet are

$$\left. \begin{aligned} E \frac{\partial u}{\partial x} &= \sigma_x - \nu \sigma_y, \\ E \frac{\partial v}{\partial y} &= \sigma_y - \nu \sigma_x, \\ \frac{E}{2(1 + \nu)} \left(\frac{\partial u}{\partial y} + \frac{\partial v}{\partial x} \right) &= \tau_{xy} \end{aligned} \right\} \dots \dots \dots (2)$$

and

$$\frac{E}{2(1 + \nu)} \left(\frac{\partial u}{\partial y} + \frac{\partial v}{\partial x} \right) = \tau_{xy}$$

and for the X- and Y-members

$$\left. \begin{aligned} E \frac{\partial u}{\partial x} &= \sigma_x \text{ (it is unaffected by strains in the } y\text{-direction)} \\ \text{and similarly} \\ E \frac{\partial v}{\partial y} &= \sigma_y \end{aligned} \right\} \dots \dots \dots (3)$$

u and v can be eliminated from equation (2) to give the 'equation of compatibility' expressed in terms of stresses,

$$\frac{\partial^2}{\partial y^2} (\sigma_x - \nu \sigma_y) + \frac{\partial^2}{\partial x^2} (\sigma_y - \nu \sigma_x) = 2(1 + \nu) \frac{\partial^2 \tau_{xy}}{\partial x \partial y} \dots \dots \dots (4)$$

We now consider the equilibrium of a small element of the stiffened sheet. We introduce $\bar{\sigma}_x$, $\bar{\sigma}_y$ and $\bar{\tau}_{xy}$ the 'mean applied stresses' which are defined so that $t\bar{\sigma}_x$, $t\bar{\sigma}_y$ and $t\bar{\tau}_{xy}$ are the forces in the stiffened sheet per unit length.

Resolving along the y - and x -axes we find that for equilibrium of an element of stiffened sheet

$$\left. \begin{aligned} \frac{\partial \bar{\tau}_{xy}}{\partial x} + \frac{\partial \bar{\sigma}_y}{\partial y} &= 0 \\ \frac{\partial \bar{\tau}_{xy}}{\partial y} + \frac{\partial \bar{\sigma}_x}{\partial x} &= 0 \end{aligned} \right\} \dots \dots \dots (5)$$

These equations of equilibrium will be satisfied if we introduce² a stress-function ϕ such that

$$\left. \begin{aligned} \bar{\sigma}_x &= K \frac{\partial^2 \phi}{\partial y^2} \\ \bar{\sigma}_y &= K \frac{\partial^2 \phi}{\partial x^2} \\ \bar{\tau}_{xy} &= -K \frac{\partial^2 \phi}{\partial x \partial y} \end{aligned} \right\} \dots \dots \dots (6)$$

The constant K has been chosen for convenience to be

$$K = 1 + X + Y + c^2 XY (1 + \nu)(1 + s^2 - \nu c^2) \dots \dots \dots (7)$$

The sheet stresses are found in terms of the stress function by expressing them first in terms of $\bar{\sigma}_x$, $\bar{\sigma}_y$ and $\bar{\tau}_{xy}$,

$$\left. \begin{aligned} \bar{\sigma}_x &= \sigma_x + X\sigma_X + s^2Y\sigma_Y \\ \bar{\sigma}_y &= \sigma_y + c^2Y\sigma_Y \\ \bar{\tau}_{xy} &= \tau_{xy} + scY\sigma_Y \end{aligned} \right\} \dots \dots \dots (8)$$

The stresses in the sheet can now be expressed as follows

$$\left. \begin{aligned} \sigma_x &= A \frac{\partial^2 \phi}{\partial x^2} + B \frac{\partial^2 \phi}{\partial x \partial y} + C \frac{\partial^2 \phi}{\partial y^2} \\ \sigma_y &= D \frac{\partial^2 \phi}{\partial x^2} + E \frac{\partial^2 \phi}{\partial x \partial y} + F \frac{\partial^2 \phi}{\partial y^2} \\ \tau_{xy} &= G \frac{\partial^2 \phi}{\partial x^2} + H \frac{\partial^2 \phi}{\partial x \partial y} + J \frac{\partial^2 \phi}{\partial y^2} \end{aligned} \right\} \dots \dots \dots (9)$$

where

$$\left. \begin{aligned} A &= \nu X - s^2 Y + (1 + \nu) s^2 Y (s^2 + 2\nu c^2 X) \\ B &= 2scY(1 + \nu)(s^2 + \nu c^2 X) \\ C &= 1 + c^2 Y \{1 + s^2(1 + \nu)\} \\ D &= 1 + X + s^2 Y \{s^2 - \nu c^2 + 2c^2(1 + \nu)(1 + X)\} \\ E &= 2sc^3 Y(1 + \nu)(1 + X) \\ F &= c^2 Y(\nu c^2 - s^2) \\ G &= -scY\{c^2 - \nu s^2 + c^2 X(1 - \nu^2)\} \\ H &= -1 - X - Y + 2s^2 c^2 Y(1 + \nu) - c^4 XY(1 - \nu^2) \\ J &= scY(\nu c^2 - s^2) \end{aligned} \right\} \dots \dots \dots (10)$$

and the stresses in the X- and Y-members are

$$\left. \begin{aligned} \sigma_x &= (A - \nu D) \frac{\partial^2 \phi}{\partial x^2} + (B - \nu E) \frac{\partial^2 \phi}{\partial x \partial y} + (C - \nu F) \frac{\partial^2 \phi}{\partial y^2} \\ \sigma_y &= \{c^2 - \nu s^2 + c^2 X(1 - \nu^2)\} \frac{\partial^2 \phi}{\partial x^2} \\ &\quad - 2sc(1 + \nu)(1 + X) \frac{\partial^2 \phi}{\partial x \partial y} - (\nu c^2 - s^2) \frac{\partial^2 \phi}{\partial y^2} \end{aligned} \right\} \dots \dots \dots (11)$$

The equation of compatibility (equation 4) is expressed in terms of ϕ by substituting in it the values of σ_x , σ_y , τ_{xy} given by equation (9). This compatibility equation reduces to

$$\alpha \frac{\partial^4 \phi}{\partial x^4} + 4\beta \frac{\partial^4 \phi}{\partial x^3 \partial y} + 2\gamma \frac{\partial^4 \phi}{\partial x^2 \partial y^2} + 4\delta \frac{\partial^4 \phi}{\partial x \partial y^3} + \varepsilon \frac{\partial^4 \phi}{\partial y^4} = 0 \dots \dots (12)$$

where

$$\left. \begin{aligned} \alpha &= 1 + (1 + \nu)[X(1 - \nu) + s^2Y\{s^2(1 - \nu) - 2\nu^2c^2X + 2c^2(1 + X)\}] \\ \beta &= scY(1 + \nu)\{c^2(1 + X) - \nu(s^2 + \nu c^2X)\} \\ \gamma &= 1 + (1 + \nu)\{X + Y + c^4XY(1 - \nu^2) - 3s^2c^2Y(1 + \nu)\} \\ \delta &= scY(1 + \nu)(s^2 - \nu c^2) \\ \varepsilon &= 1 + c^2Y(1 + \nu)(1 + s^2 - \nu c^2) \end{aligned} \right\} \quad (13)$$

2.3. *Method of Solution.*—The solution of any problem reduces to finding a solution of equation (12) subject to the appropriate boundary conditions. If the boundary conditions are expressed in terms of applied loads (as opposed to displacements) and the boundaries are parallel to the Ox and Oy axes these conditions will be expressible simply in terms of ϕ by virtue of equation (6).

The general solution of equation (12) is given in Appendix III.

If the boundaries are parallel to the ribs and stringers it might be thought advisable to refer the stresses and the associated stress function to skew axes. This possibility is considered in Appendix IV.

3. *Particular Loading Conditions.*—If we search for solutions of equation (12) in the form of polynomials of various degrees a number of important practical problems can be solved. Consider first the case of uniform applied tension.

3.1. *Uniform Applied Tension.*—This case is of great practical importance and will be discussed in detail. To fix ideas we consider a rectangular strip, such as that represented in Fig. 1, which is subjected to a tension of tf per unit width.

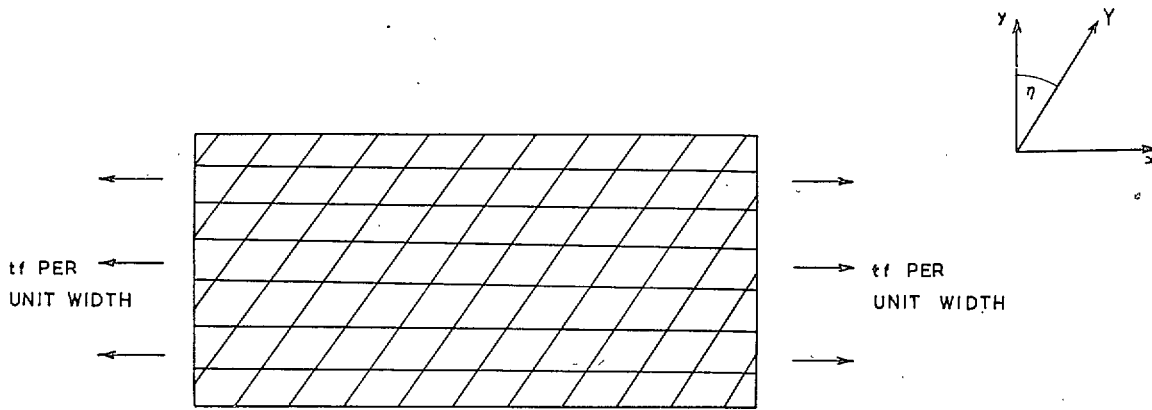

FIG. 1. Rectangular strip under tension loads.

The boundary conditions are completely satisfied if we take

$$\phi = fy^2/2K \quad \dots \quad \dots \quad \dots \quad \dots \quad \dots \quad \dots \quad \dots \quad \dots \quad \dots \quad \dots \quad (14)$$

which also satisfies equation (12) and is therefore the correct solution.

The stresses in the sheet may now be obtained from equation (9) and we find

$$\left. \begin{aligned} \sigma_x &= fC/K \\ \sigma_y &= fF/K \\ \tau_{xy} &= fJ/K \end{aligned} \right\} \dots \dots (15)$$

For positive f both σ_y and τ_{xy} are positive as η varies from 0 deg to $\tan^{-1} \sqrt{\nu}$ and negative from $\eta = \tan^{-1} \sqrt{\nu}$ to 90 deg. When $\eta = \tan^{-1} \sqrt{\nu}$, σ_y and τ_{xy} are zero and the stresses in the sheet are the same as if no Y -members were present.

For most materials $\tan^{-1} \sqrt{\nu}$ will be about 30 deg; the actual variation with ν is shown in Table 1.

TABLE 1
Variation of $\tan^{-1} \sqrt{\nu}$ with ν

ν	0.250	0.300	0.333	0.400	0.500
$\tan^{-1} \sqrt{\nu}$	26.6°	28.7°	30°	32.4°	35.3°

The presence of the 'induced' shear stress fJ/K means that the rectangular strip will deform as in Fig. 11. There is no induced shear stress when $\eta = 0$ deg, $\tan^{-1} \sqrt{\nu}$ and 90 deg. Between 0 deg and $\tan^{-1} \sqrt{\nu}$ the panel shears slightly to the right reaching a maximum at about 15 deg. For angles of sweepback between $\tan^{-1} \sqrt{\nu}$ and 90 deg the panel shears to the left and reaches at about 60 deg a maximum, which is greater than that at about 15 deg. The physical significance of this lies in the fact that for small angles of sweepback the ribs are in compression because of the Poisson effect in the sheet.

Taking $X = 0$ and $\nu = \frac{1}{4}$ it can be shown that the first peak occurs when $\eta = 14\frac{1}{2}$ deg and is given by

$$\tau_{xy}/f = \frac{+0.042Y}{1+Y}.$$

The second peak occurs when $\eta = 62\frac{1}{2}$ deg and is given by

$$\tau_{xy}/f = \frac{-0.30Y}{1+Y}.$$

In a practical structure, in which Y will probably be less than 1.0 and X greater than zero, the induced shear stress will therefore be less than 15 per cent of the direct stress. The variation of this induced shear stress with η for various values of X and Y is shown in Fig. 12. Theories based on infinite Y over-estimate this effect considerably.

3.1.1. *Stringer stresses.*—These have been plotted in Fig. 13 for various values of Y and η with $X = 1$. Up to a sweepback angle of 45 deg the contribution of the ribs in relieving the load in the stringers is negligible.

3.1.2. *Tensile stiffness*.—The 'relative tensile stiffness' may be represented by the factor

$$\frac{\text{strain in } x\text{-direction without } Y\text{-members}}{\text{strain in } x\text{-direction with } Y\text{-members}}$$

and this is simply

$$\frac{K}{(1 + X) \varepsilon}$$

The relative tensile stiffness due to the Y -members is shown in Fig. 14 for the particular cases in which $\nu = \frac{1}{4}$ and $X = 0$. Except for high degrees of sweepback the variation in stiffness is negligible.

3.2. *Uniform Applied Shear*.—A system of applied loading such as that represented in Fig. 2 below is considered.

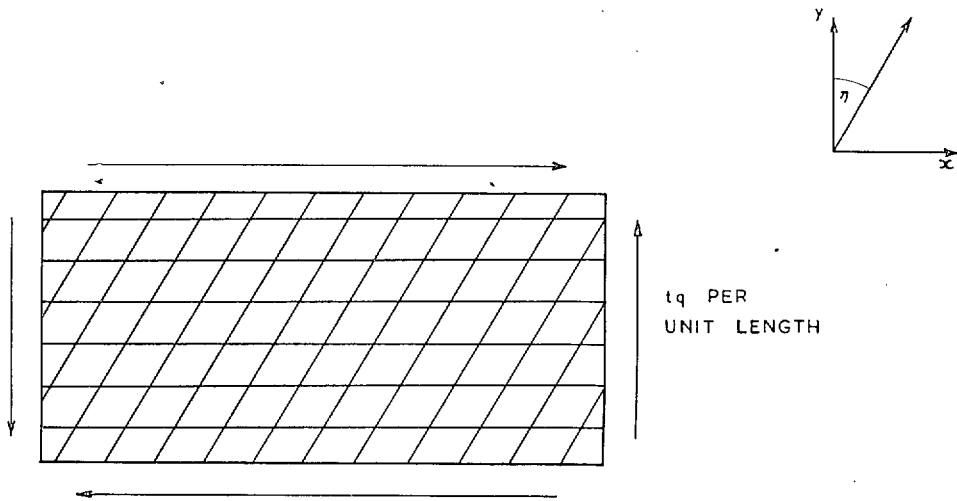

FIG. 2. Rectangular strip under shear loads.

In this case the stress function is

$$\phi = -qxy/K \quad \dots \dots \dots (16)$$

The actual sheet stresses may be obtained from equation (9) which gives

$$\left. \begin{aligned} \sigma_x &= -qB/K \\ \sigma_y &= -qE/K \\ \tau_{xy} &= -qH/K \end{aligned} \right\} \dots \dots \dots (17)$$

The induced stresses σ_x and σ_y are both compressive for positive q and η .

3.2.1. *Stringer stresses*.—The induced stress in the stringers is given by

$$\sigma_x = q(\nu E - B)/K$$

which varies with X , Y and η in exactly the same manner, apart from a factor of $2(1 + \nu)$, as did the induced shear stress in the case of uniform applied tension. Fig. 15 shows the variation of σ_x for various values of X and Y with $\nu = \frac{1}{4}$.

It will be noticed that the greatest possible value of σ_x that can occur is when $\eta = 62\frac{1}{2}$ deg and $Y = \infty$ and X is very small, in which case

$$\sigma_x = -0.6(1+\nu)q.$$

This is an extreme case, of course, which will not occur in practice.

3.2.2. *Stresses in the Y-members.*—From equation (11) we find

$$\frac{\sigma_y}{q} = \frac{2sc(1+\nu)(1+X)}{K}.$$

An extreme case arises when $\eta = 45$ deg and Y is very small, in which case

$$\sigma_y = (1+\nu)q.$$

3.2.3. *Shear stiffness.*—The ‘relative shear stiffness’ may be represented by the factor

$$\frac{\text{shear stress without Y-members}}{\text{shear stress with Y-members}} = \frac{q}{\tau_{xy}} = -\frac{K}{H}.$$

A few cases have been plotted in Fig. 16.

3.3. *Other Loading Conditions.*—The following loading conditions are now considered:—

- (a) uniform applied bending,
- (b) uniform applied bending with shear,
- (c) linear tension build-up due to shear.

In each case only the appropriate stress function is given, from which the stresses can be predicted from equations (9) and (11).

3.3.1. *Uniform applied bending.*—A system of applied loading such as that represented in Fig. 3 below is considered.

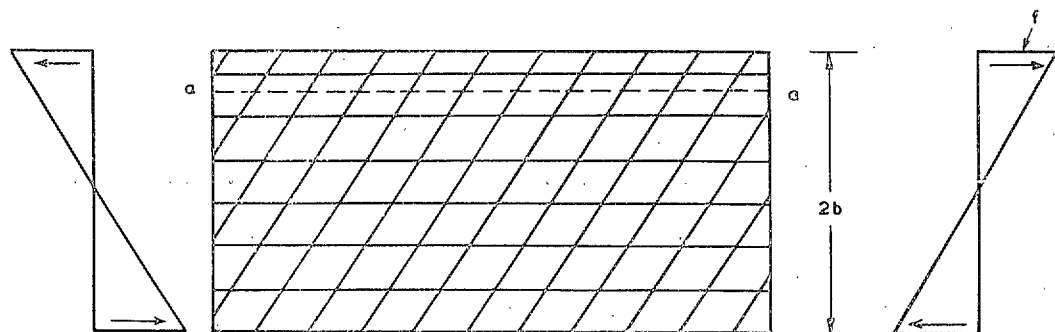

FIG. 3. Rectangular strip under bending loads.

The applied bending moment is such that $\bar{\sigma}_x = \pm f$ at $y = \pm b$.

The appropriate stress function is

$$\phi = fy^3/6bK. \quad \dots \quad (18)$$

By comparing this with equation (14) it will be seen that the stresses along a strip such as aa are identical with those which would exist if the stiffened sheet were subjected to a uniform loading of an amount appropriate to the actual loading at aa.

3.3.2. *Uniform applied bending with shear.*—The system of applied loading is represented in Fig. 4 below.

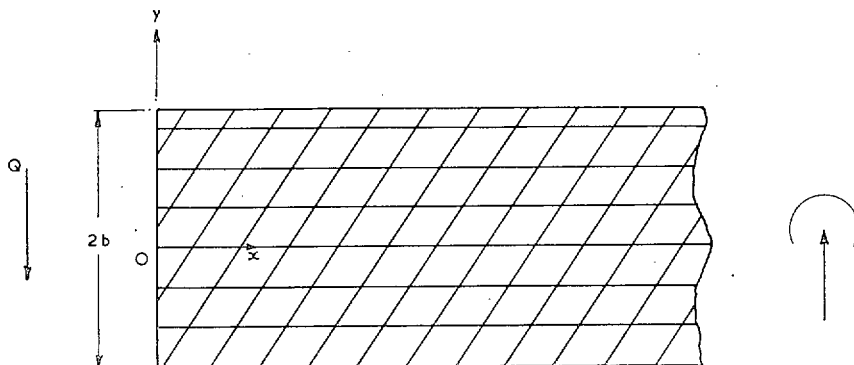

FIG. 4. Rectangular strip acting as a cantilever.

The strip is acting as a cantilever and the precise distribution of forces acting at the end is not known. Their resultant is a purely vertical load Q .

The appropriate stress function is

$$\phi = \frac{-Q}{4b^3tK} \left\{ 3b^2xy - xy^3 + (\delta/\varepsilon)(y^4 - 2b^2y^2) \right\} \dots \dots (19)$$

If the applied load distribution at the end is not the same as that given by ϕ the stress distribution in the stiffened sheet a small distance from the end will rapidly approach that given by ϕ .

3.3.3. *Linear tension build-up due to shear.*—The system of applied loading is represented in Fig. 5 below. The condition at the end, $x = 2a$, is that of uniform applied direct loading consistent with overall equilibrium. A uniform applied shear of tq per unit length is applied to the edges $y = \pm b$.

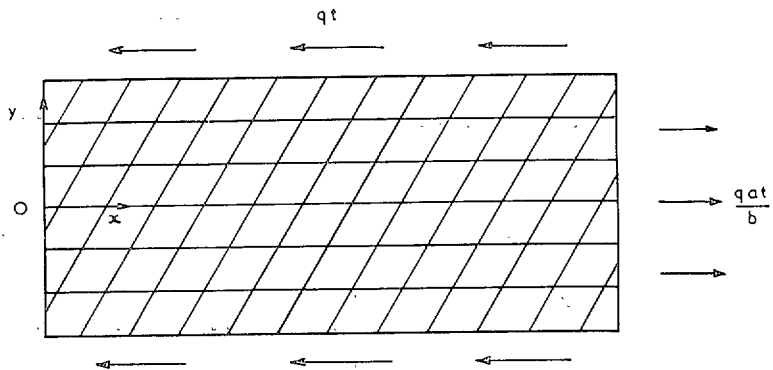

FIG. 5. Rectangular strip under tension and shear loads.

The compatibility condition and all the boundary conditions, except that of a free edge along $x = 0$ are satisfied by

$$\phi = qxy^2/2bK \dots \dots \dots (20)$$

The stresses in the sheet a short distance from $x = 0$ will rapidly approach those given by the stress function.

4. *Application to a Rectangular Box.*—We shall now investigate the distortions of, and the stresses in, a 4-boom cylindrical box of singly symmetrical rectangular section subjected to bending and torsion moments. The results of this investigation will form the basis for the ‘stressing’ of a swept airplane wing in regions away from structural and loading discontinuities. (The word ‘stressing’ here includes the determination of stiffnesses.)

4.1. *Direction of Zero-curvature Axis.*—The type of structure considered and the directions of the applied moments are represented in Fig. 6 below. We search for an axis (called here the axis of zero curvature) about which applied moments will produce pure twisting about Ox .

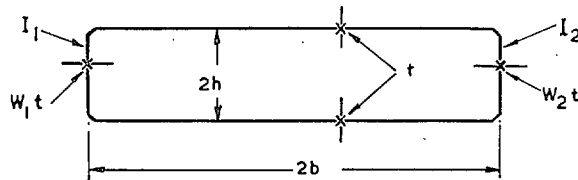

FIG. 6 a. Cross-section of the box.

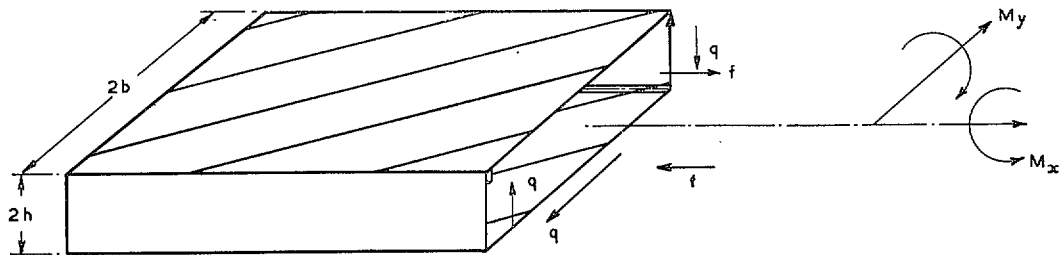

FIG. 6 b. The rectangular box under general loading.

For there to be no curvature the boom stress must be zero and therefore the applied loading on the top and bottom panels must be as in Appendix II,
i.e.,

$$f = (2\delta/\varepsilon)q. \quad \dots \dots \dots (21)$$

If we regard the signs for f and q to be positive for the top and bottom panel when acting in the sense of Fig. 6, we can express M_x and M_y (the components of the moment M_{xc}) in terms of f and q ,

$$\left. \begin{aligned} M_y &= 4bhtf \\ \text{and } M_x &= -8bhtq \end{aligned} \right\} \dots \dots \dots (22)$$

Combining equations (21) and (22) we find that the condition for zero curvature is that the moment is applied about an axis which makes an angle

$$\xi_{zc} = -\tan^{-1}(\delta/\varepsilon) \quad \dots \dots \dots (23)$$

with Ox . It will be noticed that the front and rear spars take no bending load so that this part of the analysis can be applied to a structure with asymmetric or varying booms.

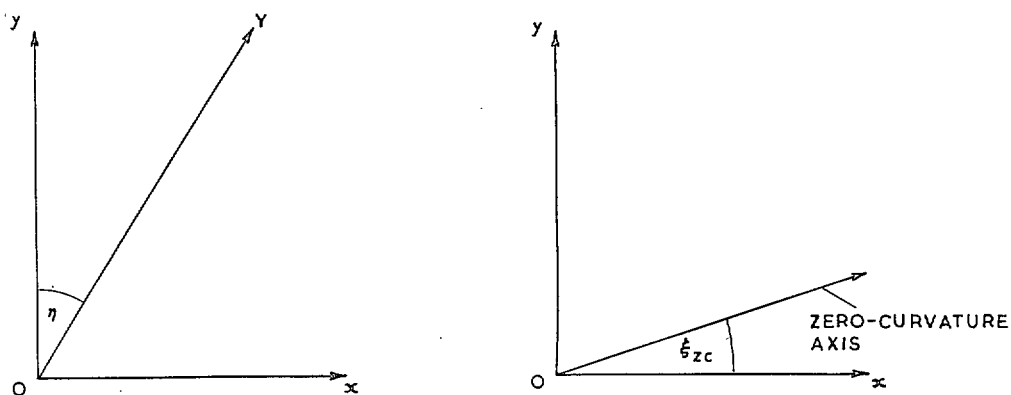

FIG. 7. Direction of zero-curvature axis.

Referring to Fig. 17 where ξ_{zc} has been plotted for various values of Y , ν and η (it is, of course, independent of X) it will be noticed that ξ_{zc} is positive over the range $0 \text{ deg} < \eta < \tan^{-1} \sqrt{\nu}$ and negative over the range $\tan^{-1} \sqrt{\nu} < \eta < 90 \text{ deg}$.

The particular case when Y is infinite reduces to the form

$$\tan \xi_{zc} = \frac{s(\nu c^2 - s^2)}{c(1 + s^2 - \nu c^2)}$$

which is in agreement with the result found in Ref. 3 (equation 137a).

For comparison this is shown on Fig. 17b where a marked difference between $Y = \infty$ and $Y = 1$, say, can be noticed.

4.1.1. *Torsional stiffness*.—If a moment M_{zc} is applied about the zero-curvature axis the twist per unit length θ will be such that

$$\frac{G\theta}{M_{zc}} = \frac{\cos \xi_{zc}}{32b^2h^2t} \left\{ h \left(\frac{1}{W_1} + \frac{1}{W_2} \right) + \frac{2b(2\delta J - \epsilon H)}{\epsilon K} \right\} \quad \dots \quad (24)$$

4.2. *Direction of Zero-twist Axis*.—The type of structure considered and the directions of the applied moments are as shown in Fig. 6. We search for an axis (called here the axis of zero twist) about which applied moments will produce pure flexure about Oy .

For there to be no twisting about the axis Ox the shear stresses in the webs and in the panels must be such as to produce only warping of a section, from which it can be deduced that

$$\left. \begin{aligned} \frac{q}{f} &= \frac{J}{H - \frac{hK}{2b} \left(\frac{1}{W_1} + \frac{1}{W_2} \right)} \\ &= Z_1, \text{ say.} \end{aligned} \right\} \dots \quad (25)$$

With such an applied loading the stress in the booms will be

$$\left. \begin{aligned} \sigma_x &= f(\epsilon - 2\delta Z_1)/K \\ &= Z_2 f, \text{ say,} \end{aligned} \right\} \dots \quad (26)$$

and the condition for zero twist is such that the moment is applied about an axis that makes with Oy an angle

$$\left. \begin{aligned} \xi_{zt} &= -\tan^{-1} \left(\frac{2Z_1}{1 + AZ_2} \right) \\ \Delta &= (I_1 + I_2)/4bt^3 \end{aligned} \right\} \dots \dots \dots (27)$$

where

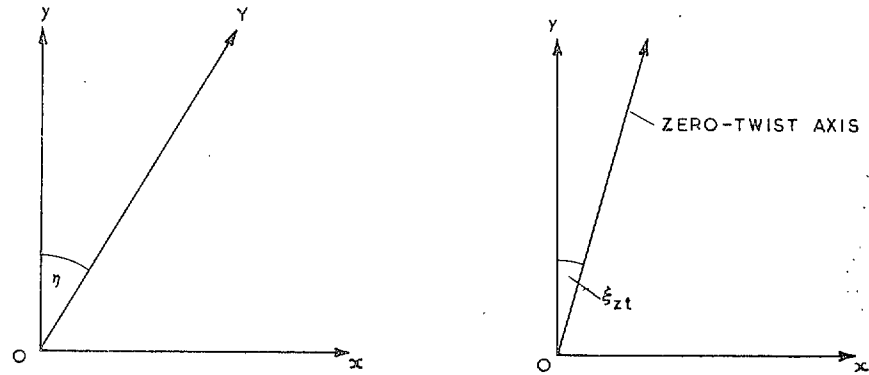

FIG. 8. Direction of zero-twist axis.

ξ_{zt} has been plotted in Fig. 18 for a variety of structural parameters.

It will be noticed that ξ_{zt} is positive over the range $0 \text{ deg} < \eta < \tan^{-1} \sqrt{\nu}$ and negative over the range $\tan^{-1} \sqrt{\nu} < \eta < 90 \text{ deg}$, from which it follows that the direction of ξ_{zc} and ξ_{zt} are at right-angles only when $\eta = 0 \text{ deg}$, $\tan^{-1} \sqrt{\nu}$ or 90 deg in which cases ξ_{zc} and ξ_{zt} are both zero.*

4.2.1. *Flexural stiffness.*—If a moment M_{zt} is applied about the zero-twist axis the radius of curvature R of the box will be such that

$$\frac{RM_{zt}}{E} = \frac{(1 + AZ_2)(I_1 + I_2)}{AZ_2 \cos \xi_{zt}} \dots \dots \dots (28)$$

4.3. *Relationship Between the Torsional and Flexural Stiffnesses.*—Using the results of equations (24) and (28) it may be shown that

$$\frac{\text{torsional stiffness}}{\text{flexural stiffness}} = \frac{\sin \xi_{zt}}{\sin \xi_{zc}} \dots \dots \dots (29)$$

This fundamental relationship may also be deduced from Maxwell's Reciprocal Theorem.

4.4. *Resolution of General Loading.*—To determine the distortion of a box under a general system of moments it will be necessary first to resolve these moments in terms of M_{zc} and M_{zt} .

If arbitrary moments M_x and M_y are applied to the box they may be resolved as follows

$$\text{and} \quad \left. \begin{aligned} M_{zt} \cos (\xi_{zt} + \xi_{zc}) &= M_y \cos \xi_{zc} - M_x \sin \xi_{zc} \\ M_{zc} \cos (\xi_{zt} + \xi_{zc}) &= M_x \cos \xi_{zt} - M_y \sin \xi_{zt} \end{aligned} \right\} \dots \dots \dots (30)$$

* This result is a particular case of Maxwell's Reciprocal Theorem.

ξ_{zt} and ξ_{zc} are both comparatively small and in an aircraft wing M_y is greater than M_x so as an approximation we might take

$$M_{zt} \simeq M_y$$

and

$$M_{zc} \simeq M_x - M_y \sin \xi_{zt}.$$

An example of a swept rectangular box is discussed in Appendix I.

5. *Conclusions.*—A method for determining the stresses in a sheet reinforced by stringers and skew ribs has been developed. The assumption has been made that the discrete stringers and ribs are represented by equivalent elastic sheets. This simplification has made possible the introduction of a stress-function which, in turn, has greatly facilitated the solution of a number of practical problems.

The theory has been applied to a swept wing, in which the ribs are parallel to the direction of flight, and the following conclusions are drawn:

- (a) the flexural behaviour of a wing with less than about 40 deg sweepback may be adequately predicted by neglecting the effect of rib skewness. For very high degrees of sweepback, or particularly stiff ribs, the exact behaviour may be obtained with little extra work,
- (b) if the sweepback angle is $\tan^{-1} \sqrt{\nu}$ (about 30 deg for most materials) the contribution of the ribs to the flexural stiffness of the wing is nil,
- (c) due to sweepback, increases of the order of 5 to 20 per cent may be expected in the torsional stiffness of a wing,
- (d) there is an appreciable twisting component due to ordinary bending loads (unless the sweepback angle is around $\tan^{-1} \sqrt{\nu}$) which in a high aspect ratio wing may even be greater than the twisting component due to ordinary torsion loads,
- (e) there are two axes, called here the axes of zero curvature and zero twist, about which applied moments produce pure twist or pure flexure of the wing. Simple formulae are given for determining these axes, which are not in general at right-angles.

NOTATION

Ox, Oy	Cartesian co-ordinate such that Ox is parallel to one set of stiffening members (X -members or stringers) and Oy is cut at an angle η by OY
OY	Direction of the other set of stiffening members (Y -members or ribs)
η	Angle between a line parallel to the Y -members and a line normal to the X -members
=	Sweepback angle of a wing in which the Y -members (or ribs) are parallel to the direction of flight
E	Young's modulus for the sheet, X - and Y -members
G	Shear modulus for the sheet
ν	Poisson's ratio for the sheet
t	Thickness of sheet
X	Relative thickness of equivalent sheet of X -members
=	$\frac{\text{section area of a stringer (or } X\text{-member)}}{t \times \text{pitch of stringers}}$

Y	Relative thickness of equivalent sheet of Y -members
$=$	$\frac{\text{effective section area of a rib (or } Y\text{-member)}}{t \times \text{pitch of ribs}}$
u, v	Displacements of a point in the sheet parallel to Ox and Oy
V	Displacement of a point in the sheet parallel to OY
σ_x, σ_y	Direct stresses in the sheet with reference axes Ox, Oy
τ_{xy}	Shear stress in sheet with reference axes Ox, Oy
σ_X, σ_Y	Direct stress in X - and Y -members respectively
$\bar{\sigma}_x, \bar{\sigma}_y, \bar{\tau}_{xy}$	Mean applied stresses (with reference axes Ox, Oy) such that loads in stiffened sheet/unit length = $t\bar{\sigma}_x, t\bar{\sigma}_y, t\bar{\tau}_{xy}$
f	Particular value for $\bar{\sigma}_x$
q	Particular value for $\bar{\tau}_{xy}$
ϕ	Stress function
$A, B, C, D, E,$ F, G, H, J	Stress function coefficients for the sheet stresses
K	Stress function coefficient for the mean applied stresses
$\alpha, \beta, \gamma, \delta, \varepsilon$	Coefficients in the stress function equation
Q	Applied load
$2b$	Breadth of strip bounded by $y = \pm b$
$2a$	Length of strip

The following additional symbols are used in the discussion on swept boxes

$2h$	Height of box of rectangular section
I_1, I_2	Moments of inertia of front and rear spars
W_1, W_2	Thicknesses of front and rear spar webs (or equivalent thicknesses capable of resisting shear) $\div t$
M_x	Moment applied to box about axis Ox
M_y	Moment applied to box about axis Oy
ξ_{zt}	Angle which zero-twist axis makes with Oy
ξ_{zc}	Angle which zero-curvature axis makes with Ox
Z_1, Z_2	Defined in equations (25), (26)
A	Defined in equation (27)
M_{zt}, M_{zc}	Moments applied about zero-twist and zero-curvature axes
R	Radius of curvature
θ	Twist per unit length of structure
k	Introduced in Appendix I
λ, μ, ρ	Introduced in Appendix III
$\alpha', \beta', \gamma',$ δ', ε'	Introduced in Appendix IV

The following abbreviations are used throughout

$$s = \sin \eta$$

$$c = \cos \eta$$

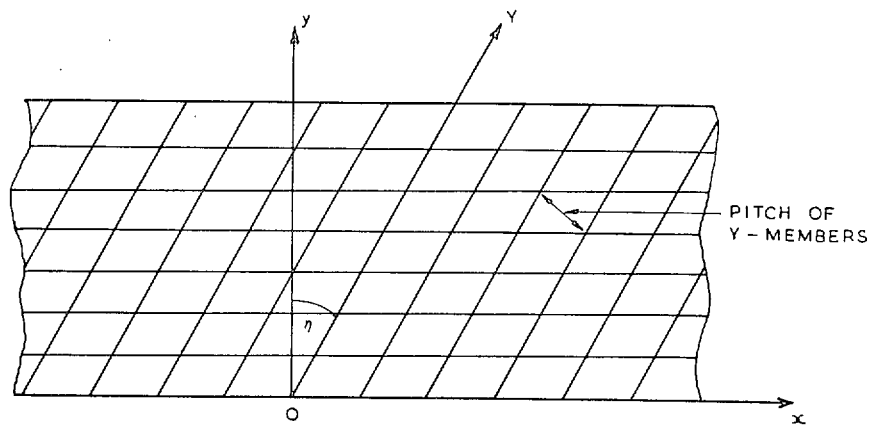

(a) FIGURE SHOWING AXES

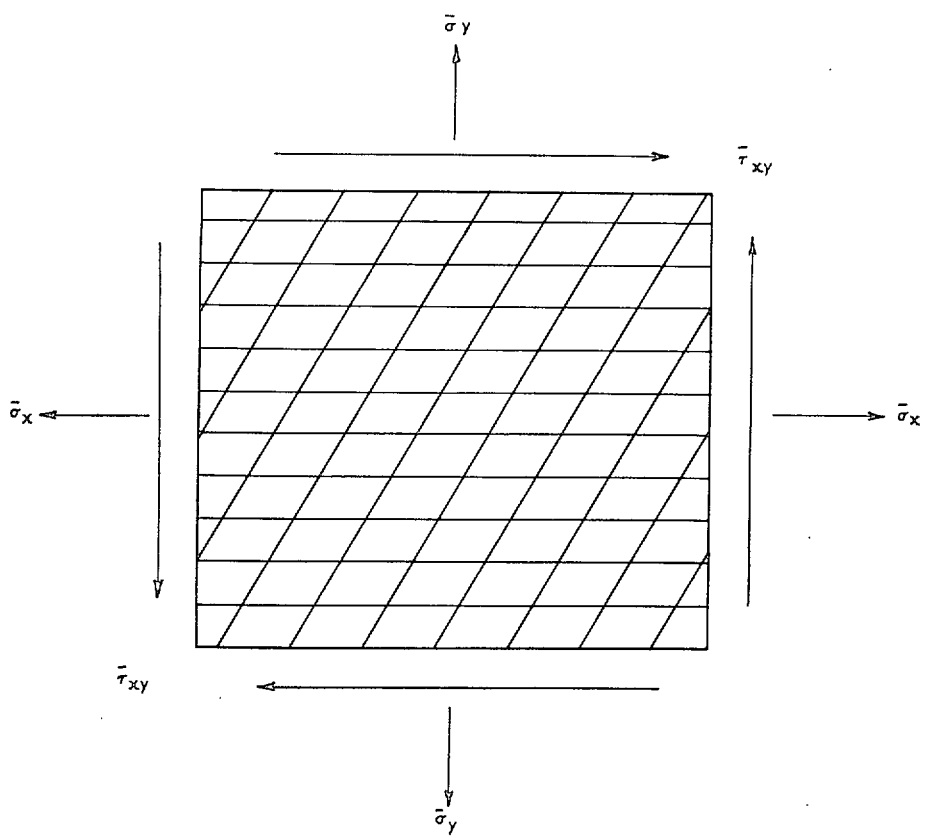

(b) MEAN APPLIED STRESSES ACTING ON AN ELEMENT OF STIFFENED SHEET

FIG. 9a and 9b. Figures showing general notation.

REFERENCES

No.	Author			Title, etc.
1	S. Timoshenko	<i>Theory of Elasticity</i> . Chapters 1 and 2. Mcgraw-Hill, 1934.
2	A. E. H. Love	<i>Mathematical Theory of Elasticity</i> . Dover Publications, 1944.
3	W. H. Wittrick	Preliminary Analysis of a Highly Swept Cylindrical Tube under Torsion and Bending. A.C.A. 39. May, 1948.
4	M. Fine	Comparison of Plain and Stringer Reinforced Sheet from the Shear Lag Stand-point. R. & M. 2648. October, 1941.

APPENDIX I

Example of Swept Box

We shall examine the behaviour of the swept box of doubly symmetrical rectangular section shown in Fig. 19 due to a uniformly distributed upload whose centre of pressure lies 35 per cent between the front and rear spars. The triangular portion bounded by section *bb* and the fuselage side (assuming that the box represents the load-carrying structure of a swept wing) is, let us suppose, stiff enough to be regarded as rigid. (The purpose of this example is to demonstrate the importance and use of the axes of zero curvature and zero twist; secondary problems such as shear lag will not be considered.)

The main structural parameters may now be determined and we find:

$$X = \frac{10 \times 0.13}{4.4} = 0.3$$

$$Y = (0.12 + \frac{h}{3} \times 0.04) \div (0.1 \times \text{rib pitch})$$

$$= 0.25$$

since $h = 6$ in. and rib pitch = 8 in.,

$$\eta = 50 \text{ deg}$$

and

$$v = \frac{1}{4}, \text{ say.}$$

$$W_1 = W_2 = \frac{0.2}{0.1} = 2,$$

$$A = \frac{I_1 + I_2}{4bh^2} = \frac{1.6 \times h^2 + 4 \times 0.2 \times h^2}{8.8 \times h^2}$$

$$= 0.27.$$

From equations (7), (10) and (13) we now have

$$\begin{array}{ll}
 K = 1.607 & F = -0.0499 \\
 A = 0.0473 & G = -0.0471 \\
 B = 0.1901 & H = -1.410 \\
 C = 1.179 & J = -0.0595 \\
 D = 1.568 & \delta = 0.0744 \\
 E = 0.1653 & \varepsilon = 1.192
 \end{array}$$

ξ_{zc} and ξ_{zt} may be found from equations (23) and (27):

$$\begin{aligned}
 \xi_{zc} &= -\tan^{-1}(\delta/\varepsilon) \\
 &= -3.57 \text{ deg} \\
 Z_1 &= 0.0366 \\
 Z_2 &= 0.738
 \end{aligned}$$

whence

$$\begin{aligned}
 \xi_{zt} &= -\tan^{-1}\left(\frac{2Z_1}{1 + AZ_2}\right) \\
 &= -3.50 \text{ deg.}
 \end{aligned}$$

The torsional and flexural stiffnesses can be obtained from equations (24) and (28) which give:

$$\begin{aligned}
 \frac{G\theta}{M_{zc}} &= \frac{1}{16b^2h^2t} \left\{ \frac{h}{W} + \frac{b(2\delta J - \varepsilon H)}{\varepsilon K} \right\} \cos \xi_{zc} \\
 &= 7.94 \times 10^{-4}, \text{ (inch radian units)}
 \end{aligned}$$

which compares with 8.94×10^{-4} if the ribs are ignored.

$$\begin{aligned}
 \frac{RM_{zt}}{E} &= \frac{4bt^2(1 + AZ_2)}{Z_2 \cos \xi_{zt}} \\
 &= 516 \text{ in.}^4
 \end{aligned}$$

which compares with 497 in.⁴ if the ribs are ignored.

It is worth noting that while the torsional stiffness increases by 13 per cent due to rib skewness the flexural stiffness increases by only 4 per cent.

The box is doubly symmetrical and so the shear centre will be at the geometrical centre of the box.

The applied moments M_x and M_y are therefore of the form

$$\begin{aligned}
 kM_x &= 0.6(x/b) \\
 kM_y &= (x/b)^2
 \end{aligned}$$

where $k = b^3$ (pressure/unit area).

M_{zt} and M_{zc} are found from equation (30)

$$\begin{aligned}
 kM_{zt} &= 1.006(x/b)^2 + 0.0377(x/b) \\
 kM_{zc} &= 0.0614(x/b)^2 + 0.604(x/b) .
 \end{aligned}$$

It will be noticed that at the root section of the box ($x/b = 9.55$) M_x and M_y contribute about the same amount to M_{zc} . Thus although the torsional stiffness has increased slightly due to rib skewness the torsional moment M_{zc} has increased considerably more so. Conversely, if the moment M_x were of the other sign (nose-down instead of nose-up) the resultant twisting of the box might be very small.

The deformation of the box due to M_x and M_y has been plotted in Fig. 20. The scale has been chosen so that with the ribs ignored the value of the vertical deflection and the rotation at the tip would be 100 units. The deformation predicted by stiff-rib theory ($Y = \infty$) is also shown.

APPENDIX II

Applied Loading to Produce Elementary Types of Distortion

(a) *Extension without shear deformation.*—By combining the results of sections 3.1 and 3.2 it can be shown that if τ_{xy} is zero

$$q = (J/H)f$$

in which case the stringer stress (which determines the extension) is

$$\{CH - JB - \nu(JE - FH)\}f/KH. \quad \dots \dots \dots (31)$$

(b) *Shear deformation without extension.*—In this case the applied loading is determined by

$$\begin{aligned} f &= \frac{(B - \nu E)q}{(C - \nu F)} \\ &= (2\delta/\varepsilon)q \end{aligned}$$

and the shear stress in the sheet, which determines the distortion of the stiffened sheet is given by

$$\tau_{xy}/q = (2\delta J - \varepsilon H)/\varepsilon K. \quad \dots \dots \dots (32)$$

It will be noticed that we have not considered the effect of an applied tensile loading f' , say, in the Oy direction, nor have we considered the extension in the Oy direction. These have been ignored because in an aircraft wing—part of one surface of which we have represented by such rectangular strips—the presence of forces $\bar{\sigma}_y$ is usually practically impossible.

However, if we include the possibility of a uniform applied loading $\bar{\sigma}_y = f'$ the condition of zero shear distortion and zero extension in the Oy direction is

$$\begin{aligned} f:f':q &= \{(HD - GE) + \nu(BG - AH)\}: \\ &\{(JE - HF) + \nu(HC - BJ)\}:\{(JD - FG) + \nu(GC - AJ)\}. \end{aligned}$$

Similarly for shear distortion alone we should have

$$f:f':q = (AE - BD):(BF - CE):(AF - CD).$$

APPENDIX III

The General Solution of the Stress-function Equation

The equation to be solved is

$$\alpha \frac{\partial^4 \phi}{\partial x^4} + 4\beta \frac{\partial^4 \phi}{\partial x^3 \partial y} + 2\gamma \frac{\partial^4 \phi}{\partial x^2 \partial y^2} + 4\delta \frac{\partial^4 \phi}{\partial x \partial y^3} + \varepsilon \frac{\partial^4 \phi}{\partial y^4} = 0. \quad \dots \quad (12 \text{ bis})$$

We search for a solution in the form

$$\phi = F(x + \lambda y),$$

where F is any function and λ is a constant. This satisfies equation (12) provided

$$\alpha + 4\beta\lambda + 2\gamma\lambda^2 + 4\delta\lambda^3 + \varepsilon\lambda^4 = 0. \quad \dots \quad (33)$$

Equation (33) will have four roots $\lambda_1, \lambda_2, \lambda_3, \lambda_4$. Thus we can take as the complete solution of the stress function equation

$$\phi = F_1(x + \lambda_1 y) + F_2(x + \lambda_2 y) + F_3(x + \lambda_3 y) + F_4(x + \lambda_4 y)$$

where the F's are four arbitrary functions.

In this form the solution may not be particularly manageable, but it may be transformed as follows:—

The four values of λ are all complex and can therefore be written as $\mu_1 \pm i\varrho_1$ and $\mu_2 \pm i\varrho_2$ and $F_1 + F_2$ may be written as

$$F_1(x + \mu_1 y + i\varrho_1 y) + F_2(x + \mu_1 y - i\varrho_1 y)$$

or as

$$G_1 \{e^{n(x + \mu_1 y + i\varrho_1 y)}\} + G_2 \{e^{n(x + \mu_1 y - i\varrho_1 y)}\}$$

or as

$$H_1 \{e^{n(x + \mu_1 y)} \sin n\varrho_1 y\} + H_2 \{e^{n(x + \mu_1 y)} \cos n\varrho_1 y\}$$

or as

$$\sum_n (A_n \sin n\varrho_1 y + B_n \cos n\varrho_1 y) e^{n(x + \mu_1 y)} \quad \dots \quad (34)$$

where G and H are arbitrary functions, n is a parameter and A_n, B_n are constants. A similar expression exists for $F_3 + F_4$, namely

$$\sum_m (C_m \sin m\varrho_2 y + D_m \cos m\varrho_2 y) e^{m(x + \mu_2 y)} \quad \dots \quad (35)$$

It may be convenient to have the trigonometric terms in equations (34) and (35) with the same period, *i.e.*, we could write $n\varrho_1 = m\varrho_2 = \bar{n}$ say. The complete solution could then be written in the form

$$\begin{aligned} \phi = & \sum_{\bar{n}} \{(A_{\bar{n}} \sin \bar{n}y + B_{\bar{n}} \cos \bar{n}y) e^{\bar{n}(x + \mu_1 y)/\varrho_1} \\ & + (C_{\bar{n}} \sin \bar{n}y + D_{\bar{n}} \cos \bar{n}y) e^{\bar{n}(x + \mu_2 y)/\varrho_2}\} \quad \dots \quad (36) \end{aligned}$$

Example

Suppose we have a structure in which

$$\begin{aligned} X &= 1 & Y &= \frac{1}{2} \\ \nu &= \frac{1}{4} & \eta &= 45 \text{ deg.} \end{aligned}$$

From equation (13) we find that

$$\alpha = 2.66 \qquad \beta = 0.264$$

$$\delta = 0.117 \qquad \varepsilon = 1.43$$

$$\gamma = 2.44$$

and the roots of

$$2.66 + 1.056\lambda + 4.88\lambda^2 + 0.468\lambda^3 + 1.43\lambda^4 = 0$$

are

$$-0.127 \pm i0.820$$

and

$$-0.0365 \pm i1.65$$

so that

$$\mu_1 = -0.127 \qquad \rho_1 = 0.820$$

$$\mu_2 = -0.0365 \qquad \rho_2 = 1.65.$$

APPENDIX IV

Boundary Conditions Parallel to the Ribs Period and Space Oblique Co-ordinates

When boundary conditions parallel to the ribs are to be satisfied it may seem advantageous to employ oblique co-ordinates. This possibility is considered here in detail. The oblique axes OX , OY and the axis OZ (normal to OY) are shown in Fig. 10 a. OZ has been introduced merely for convenience in designating the stresses acting on the sides of the elemental parallelogram shown in Fig. 10 b.

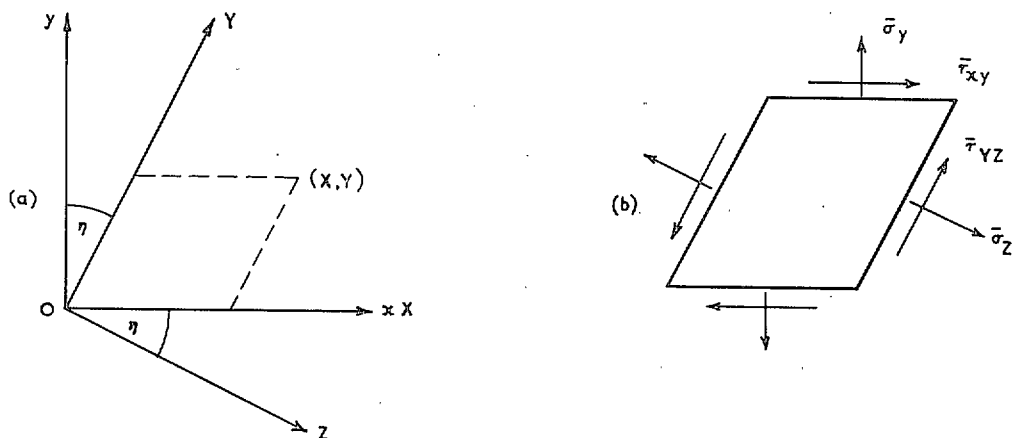

FIG. 10. Notation with oblique axes.

With the same stress function as that introduced in equation (6), but expressed in oblique co-ordinates, we have

$$\left. \begin{aligned} \bar{\sigma}_y &= K \frac{\partial^2 \phi}{\partial X^2} \\ \bar{\sigma}_z &= K \frac{\partial^2 \phi}{\partial Y^2} \\ \bar{\tau}_{xy} &= -K \left\{ \sec \eta \frac{\partial^2 \phi}{\partial X \partial Y} - \tan \eta \frac{\partial^2 \phi}{\partial X^2} \right\} \\ \bar{\tau}_{yz} &= -K \left\{ \sec \eta \frac{\partial^2 \phi}{\partial X \partial Y} - \tan \eta \frac{\partial^2 \phi}{\partial Y^2} \right\} \end{aligned} \right\} \dots \dots \dots (37)$$

The compatibility equation (see equation (12)) has now a symmetrical form in X and Y :

$$\alpha' \frac{\partial^4 \phi}{\partial X^4} + 4\beta' \frac{\partial^4 \phi}{\partial X^3 \partial Y} + 2\gamma' \frac{\partial^4 \phi}{\partial X^2 \partial Y^2} + 4\delta' \frac{\partial^4 \phi}{\partial X \partial Y^3} + \varepsilon' \frac{\partial^4 \phi}{\partial Y^4} = 0 \quad \dots \dots (38)$$

where

$$\left. \begin{aligned} \alpha' &= 1 + c^2 X(1 + \nu)(1 + s^2 - \nu c^2) \\ \beta' &= -s \{1 + c^2 X(1 + \nu)\} \\ \gamma' &= 1 + 2s^2 + c^2(1 + \nu)\{X + Y + c^4 XY(1 - \nu^2)\} \\ \delta' &= -s \{1 + c^2 Y(1 + \nu)\} \\ \varepsilon' &= 1 + c^2 Y(1 + \nu)(1 + s^2 - \nu c^2) \end{aligned} \right\} \dots \dots \dots (39)$$

The stresses in the sheet may be found from equation (9) by using the operational identities:

$$\left. \begin{aligned} \frac{\partial^2}{\partial x^2} &\equiv \frac{\partial^2}{\partial X^2} \\ \frac{\partial^2}{\partial x \partial y} &\equiv \sec \eta \frac{\partial^2}{\partial X \partial Y} - \tan \eta \frac{\partial^2}{\partial X^2} \\ \frac{\partial^2}{\partial y^2} &\equiv \sec^2 \eta \frac{\partial^2}{\partial Y^2} - 2 \sec \eta \tan \eta \frac{\partial^2}{\partial X \partial Y} + \tan^2 \eta \frac{\partial^2}{\partial X^2} \end{aligned} \right\} \dots \dots \dots (40)$$

The boundary strains may be determined from σ_x and σ_y , which reduce simply to

$$\left. \begin{aligned} \sigma_x &= \sec^2 \eta \left\{ (s^2 - \nu c^2) \frac{\partial^2 \phi}{\partial X^2} + 2\delta' \frac{\partial^2 \phi}{\partial X \partial Y} + \varepsilon' \frac{\partial^2 \phi}{\partial Y^2} \right\} \\ \sigma_y &= \sec^2 \eta \left\{ \alpha' \frac{\partial^2 \phi}{\partial X^2} + 2\beta' \frac{\partial^2 \phi}{\partial X \partial Y} + (s^2 - \nu c^2) \frac{\partial^2 \phi}{\partial Y^2} \right\} \end{aligned} \right\} \dots \dots \dots (41)$$

It will be noticed from a consideration of Appendix III that there is little or nothing to be gained by employing oblique axes.

This is due, mathematically, to the non-orthogonality of functions of the type given in equation (36) caused by the presence of the μ 's. (There will, of course, be μ 's in the solution of equation (38).)

The following relations are given here for completeness:

$$\begin{aligned} \bar{\sigma}_z &= K \left(s^2 \frac{\partial^2 \phi}{\partial x^2} + 2sc \frac{\partial^2 \phi}{\partial x \partial y} + c^2 \frac{\partial^2 \phi}{\partial y^2} \right) \\ \bar{\tau}_{yz} &= -K \left(sc \frac{\partial^2 \phi}{\partial x^2} + (c^2 - s^2) \frac{\partial^2 \phi}{\partial x \partial y} - sc \frac{\partial^2 \phi}{\partial y^2} \right). \end{aligned}$$

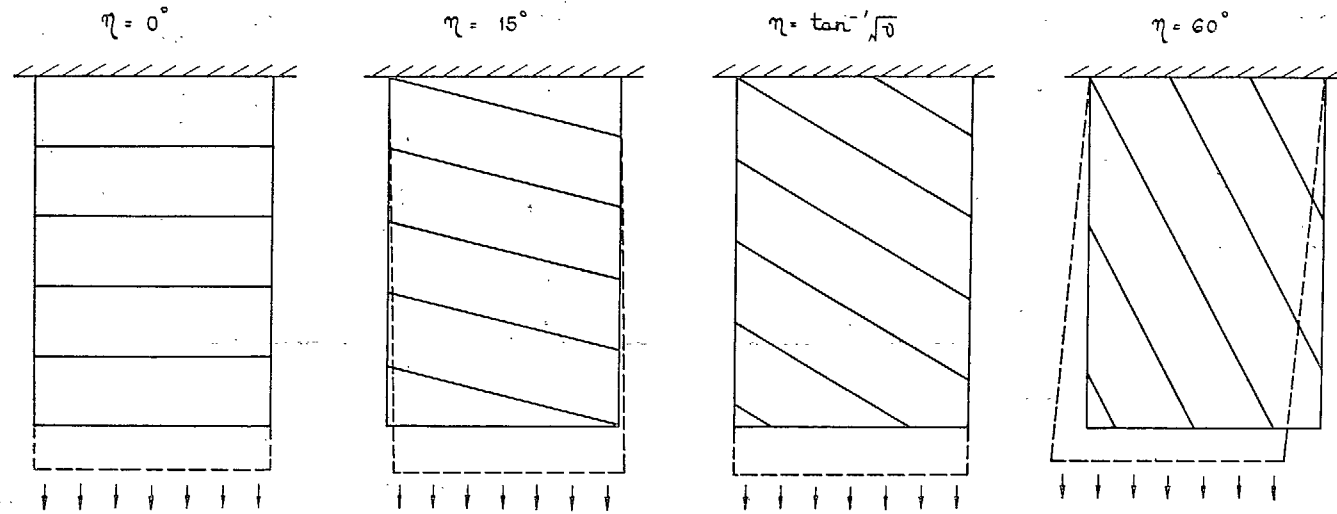

FIG. 11. Enlarged diagrams of distortion of strip under uniform applied tension ($\nu = 0.3$, $Y = \infty$).

22

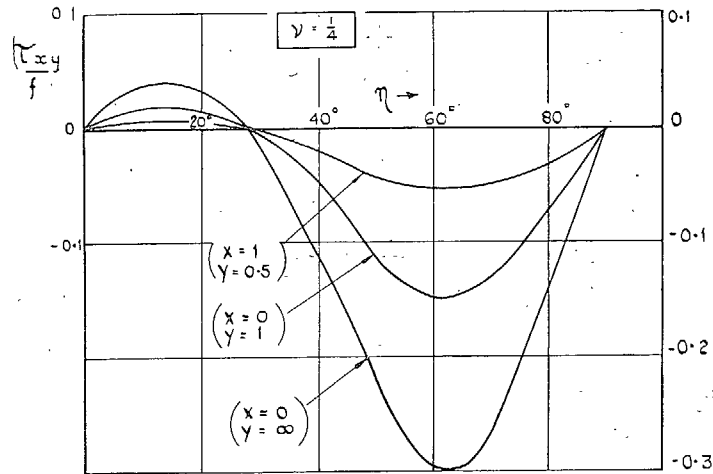

FIG. 12. Induced shear stress due to uniform applied tension.

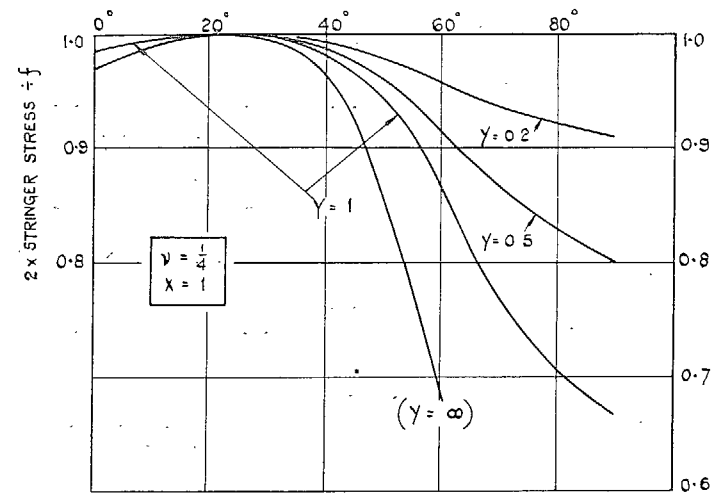

FIG. 13. Variation of stringer stress with sweepback angle : uniform applied tension.

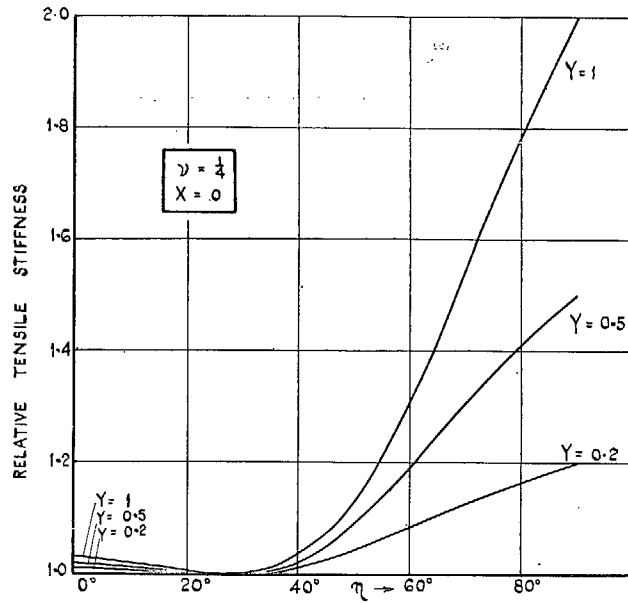

FIG. 14. Variation of relative tensile stiffness with sweepback angle.

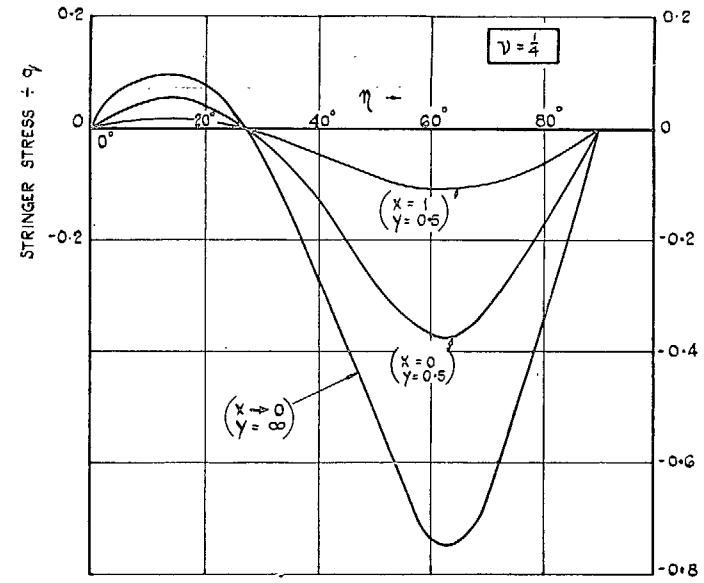

FIG. 15. Induced stringer stress due to uniform applied shear.

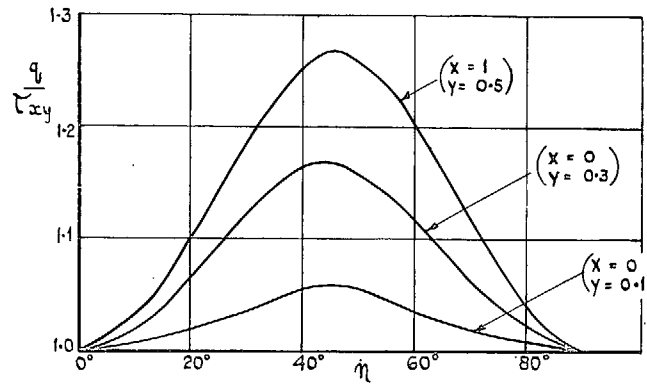
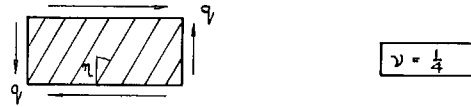

FIG. 16. Variation of relative shear stiffness with sweepback angle.

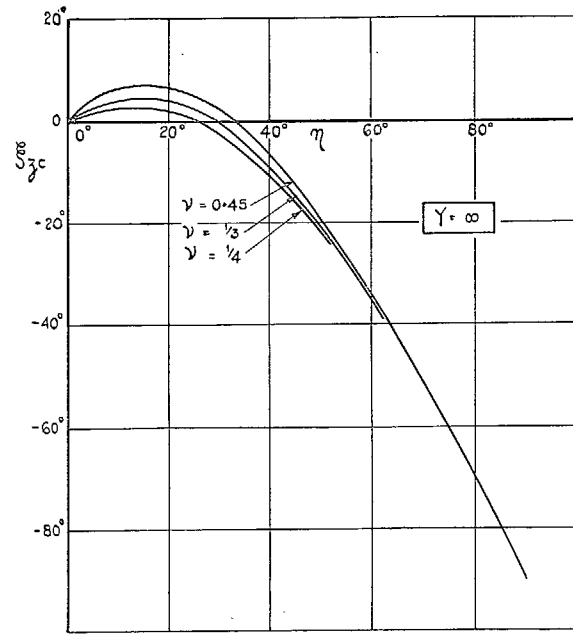

FIG. 17 a. Variation of ξ_{zc} .

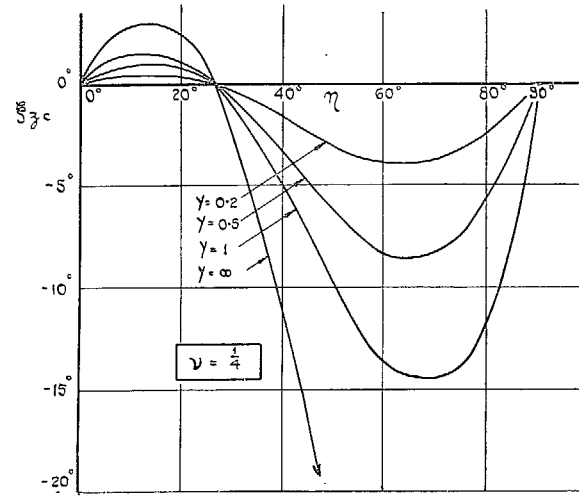

FIG. 17 b. Variation of ξ_{zc} .

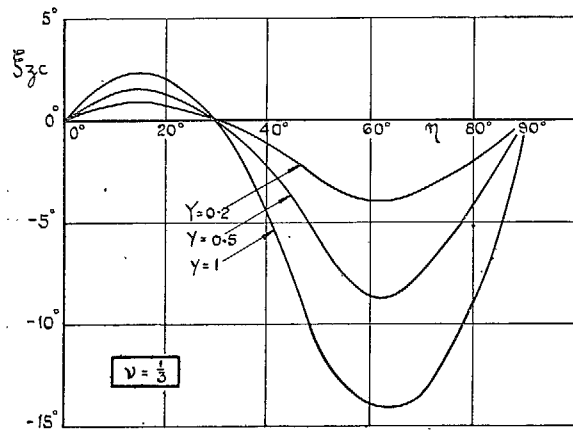

FIG. 17 c. Variation of ξ_{zc} .

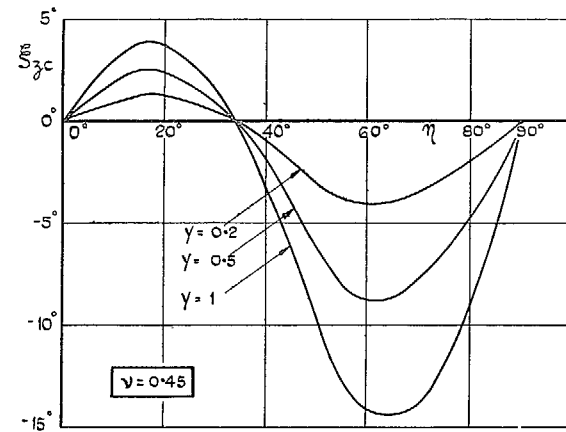

FIG. 17 d. Variation of ξ_{zc} .

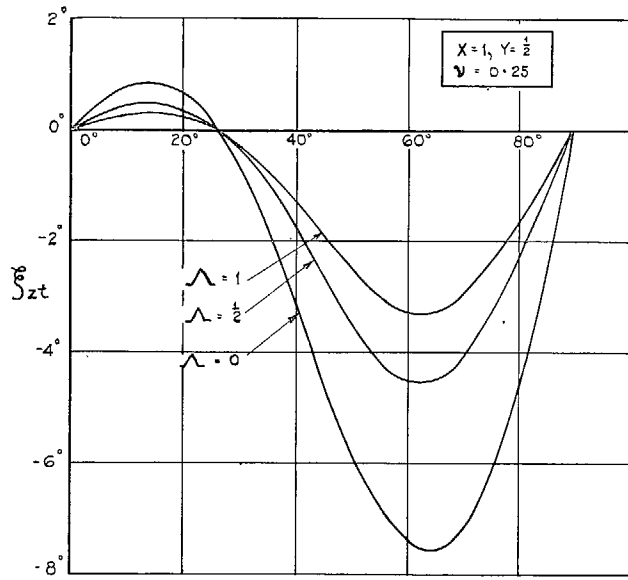

FIG. 18 a. Variation of ξ_{zt} .

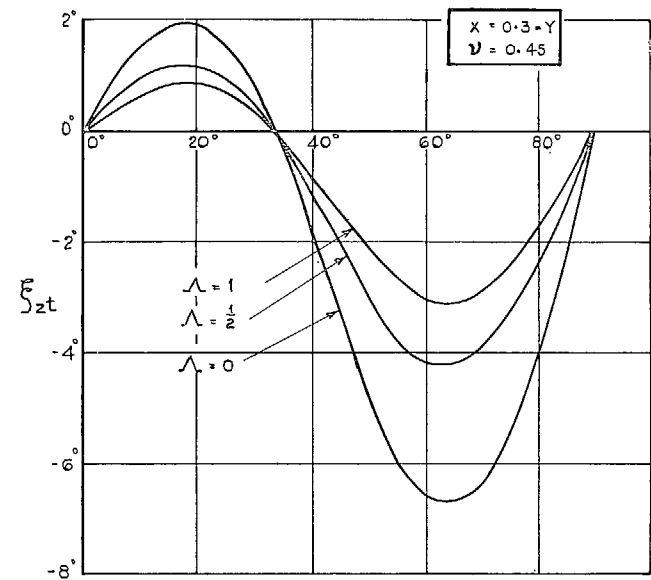

FIG. 18 b. Variation of ξ_{zt} .

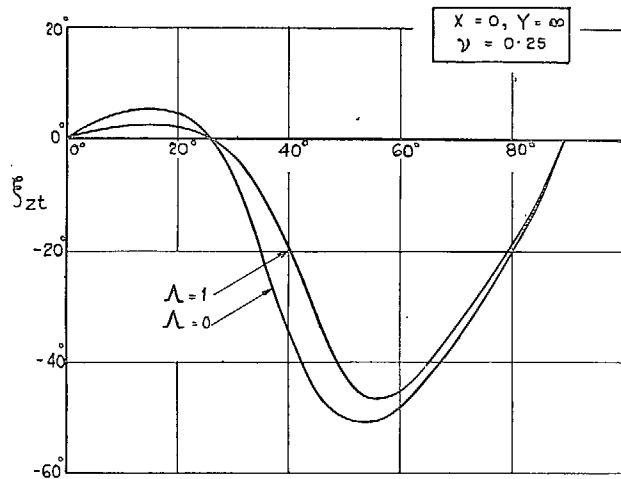

FIG. 18 c. Variation of ξ_{zt} .

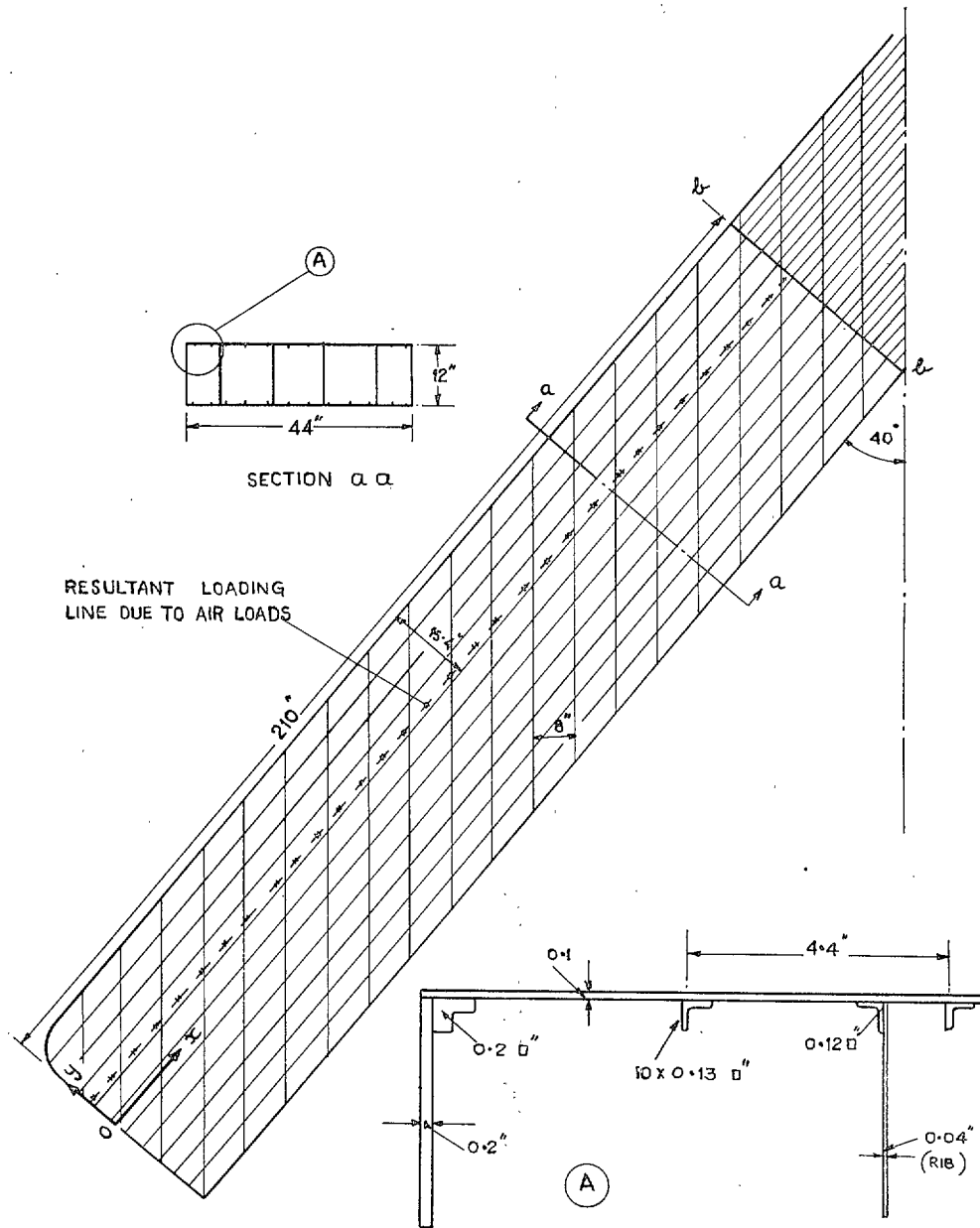
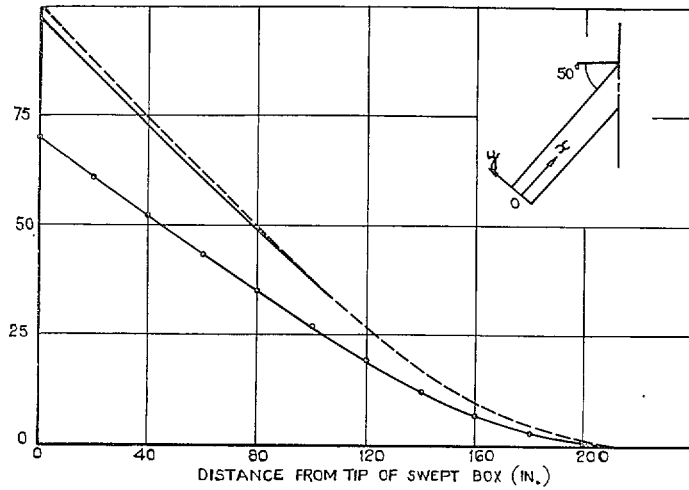
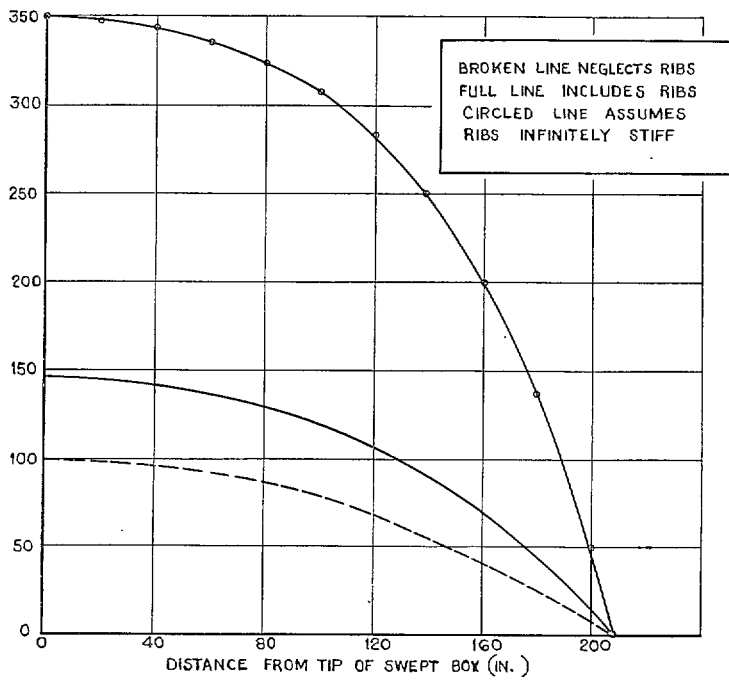

FIG. 19. Details of swept box used as example.



(a) VERTICAL DEFLECTION



(b) ROTATION ABOUT O_x

FIG. 20 a and 20 b. Deformation of swept box used in example.

Publications of the Aeronautical Research Council

ANNUAL TECHNICAL REPORTS OF THE AERONAUTICAL RESEARCH COUNCIL (BOUND VOLUMES)

- 1936 Vol. I. Aerodynamics General, Performance, Airscrews, Flutter and Spinning. 40s. (40s. 9d.)
Vol. II. Stability and Control, Structures, Seaplanes, Engines, etc. 50s. (50s. 10d.)
- 1937 Vol. I. Aerodynamics General, Performance, Airscrews, Flutter and Spinning. 40s. (40s. 10d.)
Vol. II. Stability and Control, Structures, Seaplanes, Engines, etc. 60s. (61s.)
- 1938 Vol. I. Aerodynamics General, Performance, Airscrews. 50s. (51s.)
Vol. II. Stability and Control, Flutter, Structures, Seaplanes, Wind Tunnels, Materials. 30s. (30s. 9d.)
- 1939 Vol. I. Aerodynamics General, Performance, Airscrews, Engines. 50s. (50s. 11d.)
Vol. II. Stability and Control, Flutter and Vibration, Instruments, Structures, Seaplanes, etc. 63s. (64s. 2d.)
- 1940 Aero and Hydrodynamics, Aerofoils, Airscrews, Engines, Flutter, Icing, Stability and Control, Structures, and a miscellaneous section. 50s. (51s.)
- 1941 Aero and Hydrodynamics, Aerofoils, Airscrews, Engines, Flutter, Stability and Control, Structures. 63s. (64s. 2d.)
- 1942 Vol. I. Aero and Hydrodynamics, Aerofoils, Airscrews, Engines. 75s. (76s. 3d.)
Vol. II. Noise, Parachutes, Stability and Control, Structures, Vibration, Wind Tunnels. 47s. 6d. (48s. 5d.)
- 1943 Vol. I. (*In the press.*)
Vol. II. (*In the press.*)

ANNUAL REPORTS OF THE AERONAUTICAL RESEARCH COUNCIL—

1933-34	1s. 6d. (1s. 8d.)	1937	2s. (2s. 2d.)
1934-35	1s. 6d. (1s. 8d.)	1938	1s. 6d. (1s. 8d.)
April 1, 1935 to Dec. 31, 1936.	4s. (4s. 4d.)	1939-48	3s. (3s. 2d.)

INDEX TO ALL REPORTS AND MEMORANDA PUBLISHED IN THE ANNUAL TECHNICAL REPORTS, AND SEPARATELY—

April, 1950 - - - - R. & M. No. 2600. 2s. 6d. (2s. 7½d.)

AUTHOR INDEX TO ALL REPORTS AND MEMORANDA OF THE AERONAUTICAL RESEARCH COUNCIL—

1909-1949. R. & M. No. 2570. 15s. (15s. 3d.)

INDEXES TO THE TECHNICAL REPORTS OF THE AERONAUTICAL RESEARCH COUNCIL—

December 1, 1936 — June 30, 1939.	R. & M. No. 1850.	1s. 3d. (1s. 4½d.)
July 1, 1939 — June 30, 1945.	R. & M. No. 1950.	1s. (1s. 1½d.)
July 1, 1945 — June 30, 1946.	R. & M. No. 2050.	1s. (1s. 1½d.)
July 1, 1946 — December 31, 1946.	R. & M. No. 2150.	1s. 3d. (1s. 4½d.)
January 1, 1947 — June 30, 1947.	R. & M. No. 2250.	1s. 3d. (1s. 4½d.)
July, 1951.	R. & M. No. 2350.	1s. 9d. (1s. 10½d.)

Prices in brackets include postage.

Obtainable from

HER MAJESTY'S STATIONERY OFFICE

York House, Kingsway, London, W.C.2; 423 Oxford Street, London, W.1 (Post Orders:
P.O. Box 569, London, S.E.1); 13a Castle Street, Edinburgh 2; 39, King Street, Manchester, 2;
2 Edmund Street, Birmingham 3; 1 St. Andrew's Crescent, Cardiff; Tower Lane, Bristol 1;
80 Chichester Street, Belfast, or through any bookseller