



MINISTRY OF SUPPLY

AERONAUTICAL RESEARCH COUNCIL
 REPORTS AND MEMORANDA

[Faint stamp: LIBRARY]

[Faint stamp: 52 DADS]

Suction-slot Ducting Design

By

A. G. RAWCLIFFE, B.A.,

of the Aerodynamics Division, N.P.L.

DERA Information Centre

No. 1 Building

DERA

Clapham

Bedford

MK41 6AE

el: 01234 225099

Fax: 01234 225011

ICE: Hurry Pat

Please return this publication to the Information Centre, or request a renewal, by the date last stamped below.

NAME	RETURN BY:
	NOV 1999

Crown Copyright Reserved

HER MAJESTY'S STATIONERY OFFICE

1952

FOUR SHILLINGS NET

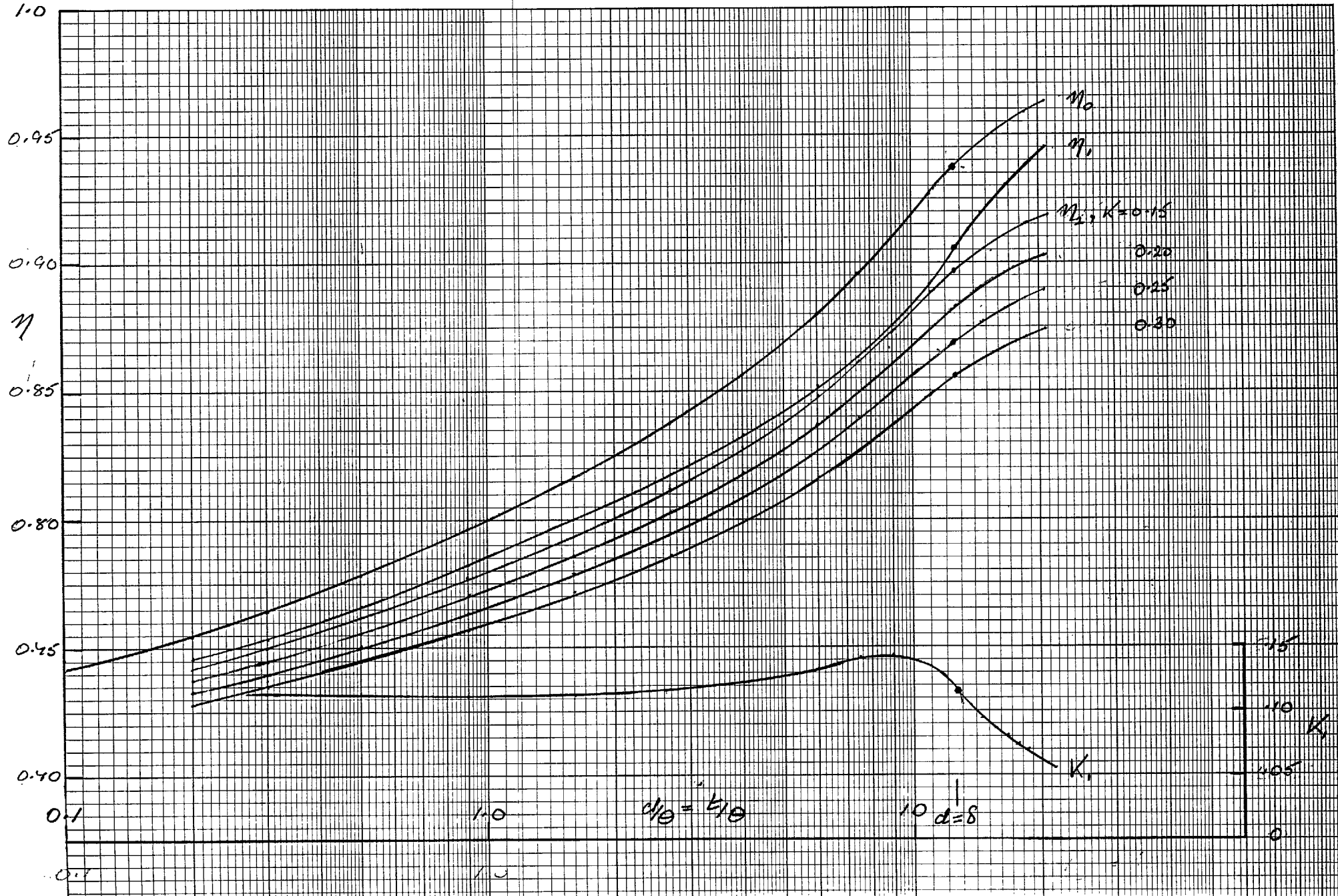

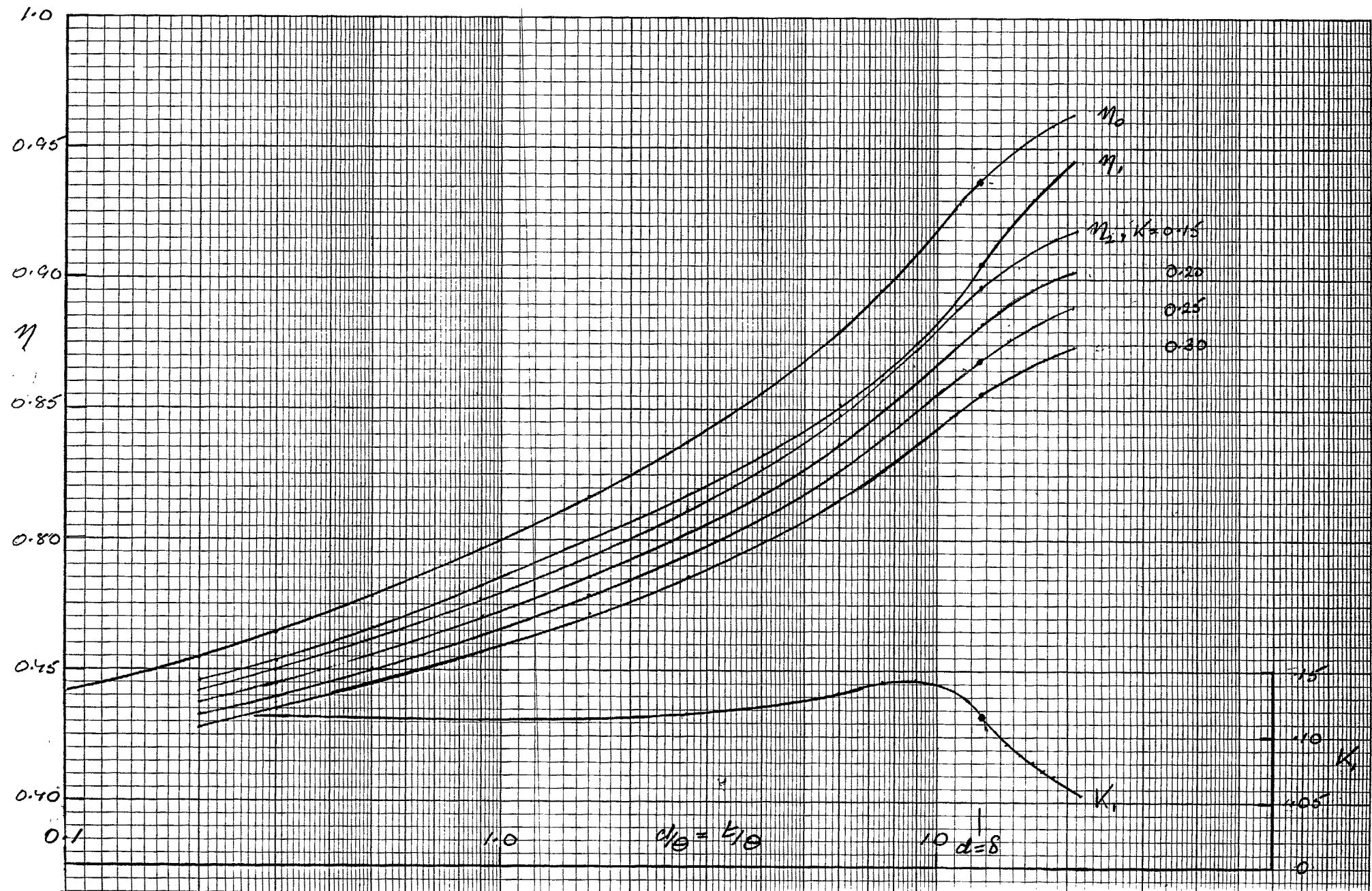

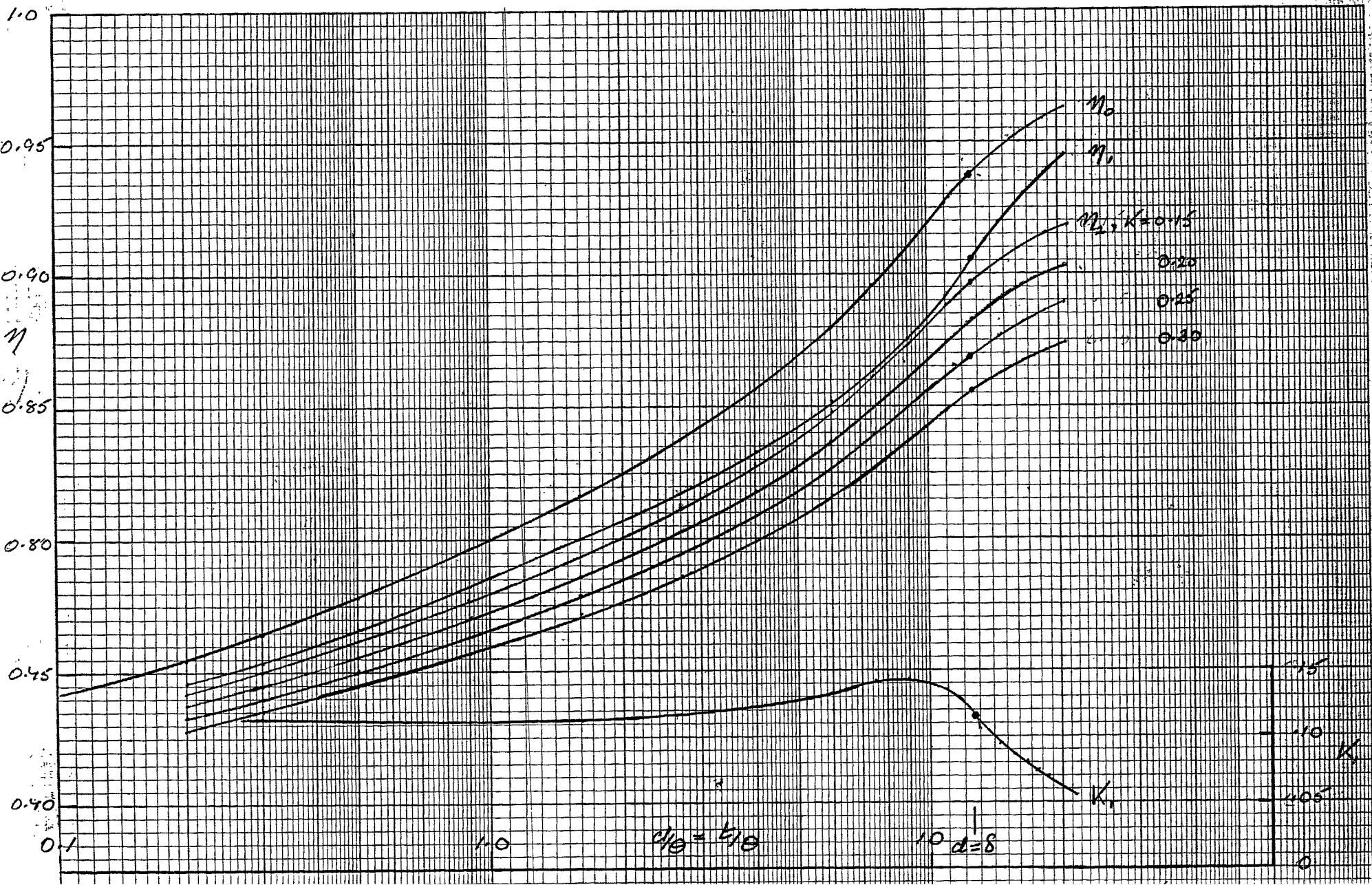

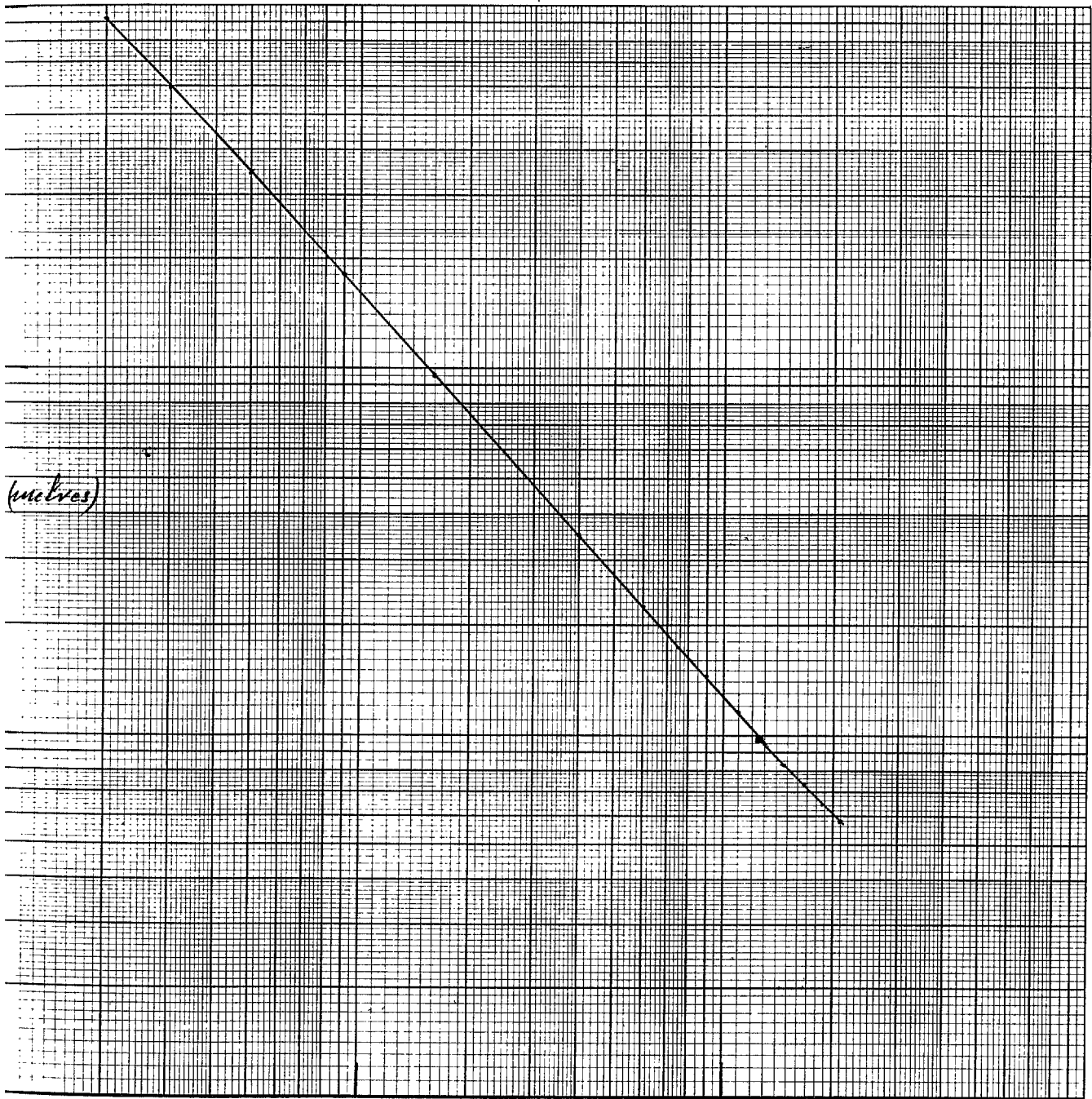

(metros)

2 3 4 5 6 7 8 9 1 2 3 4 5 6 7 8 9 1 2 3 4 5 6 7 8 9 1

1.0

0.4

10

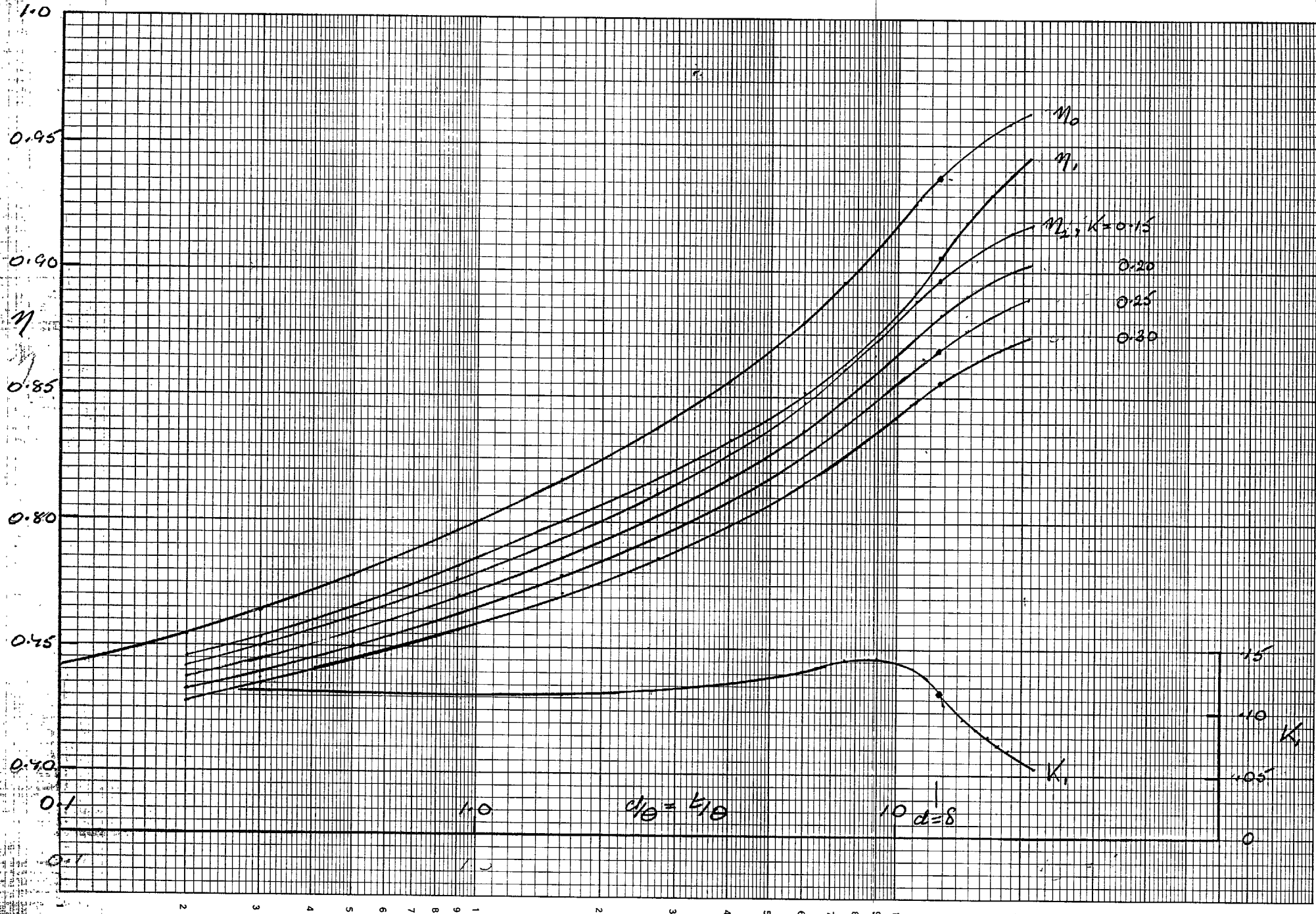

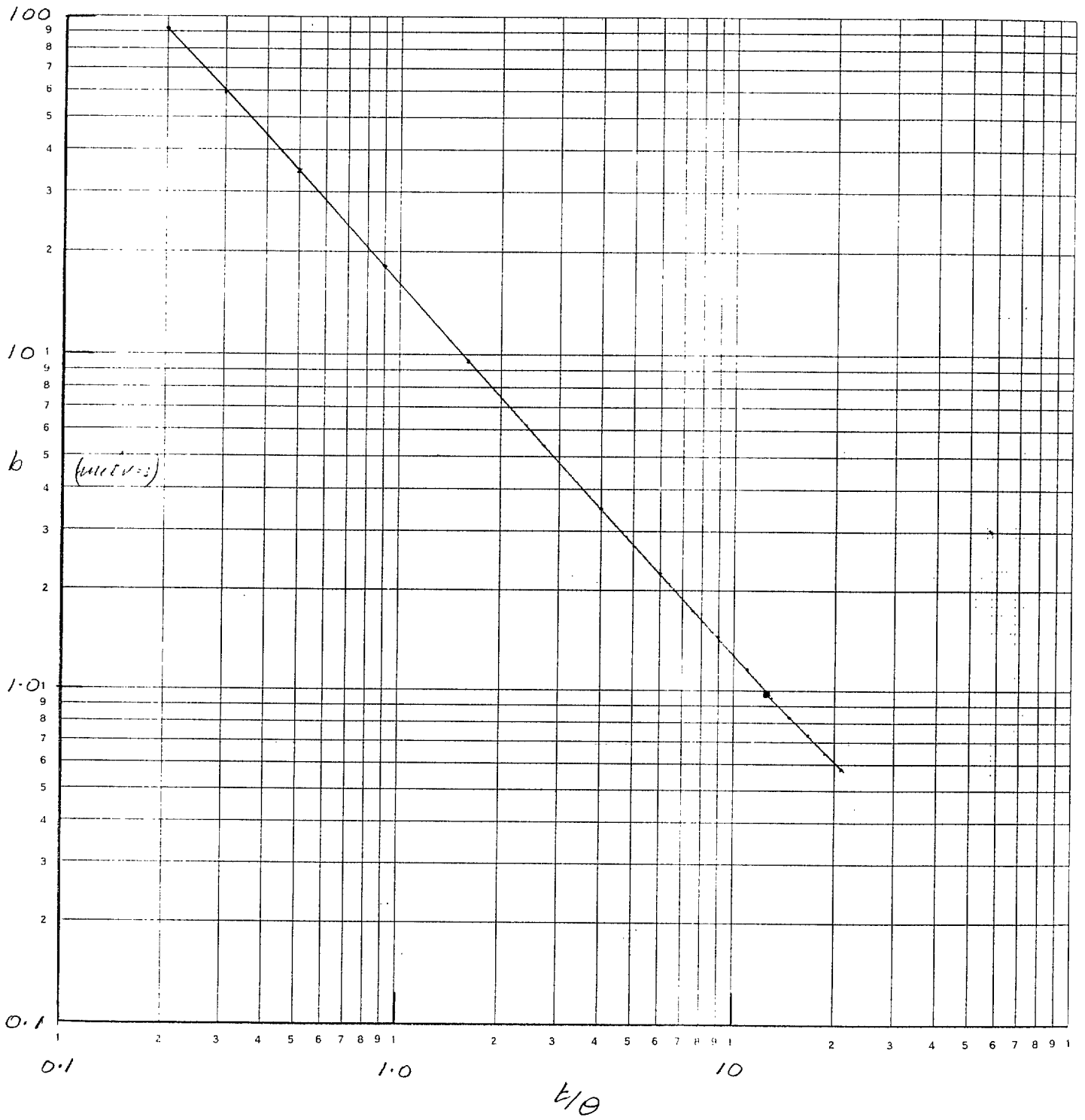

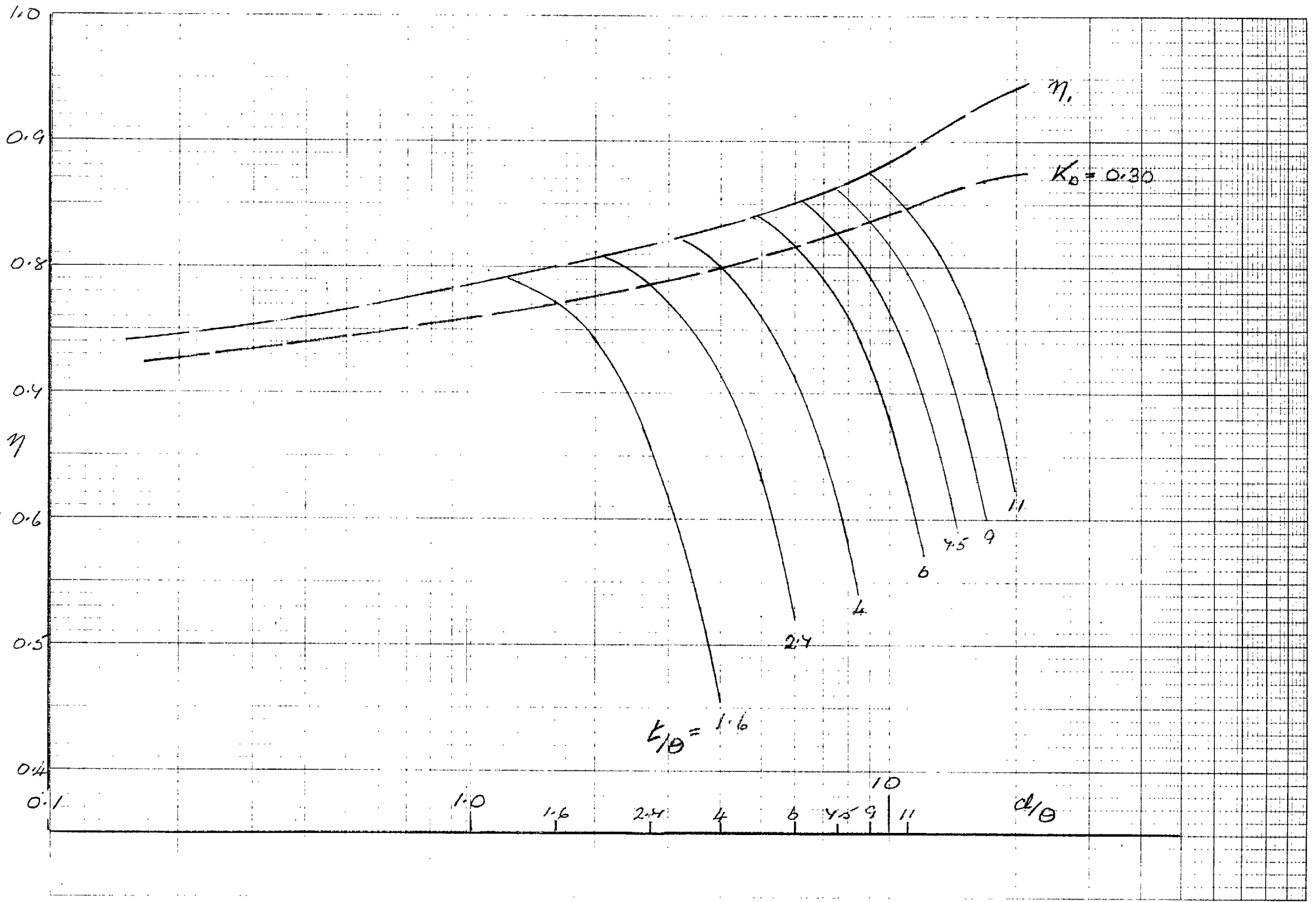

(5)

NATIONAL AERONAUTICAL ESTABLISHMENT
LIBRARY
Suction-slot Ducting Design

By

A. G. Rawcliffe, B.A., of the Aerodynamics Division, N.P.L.

Reports and Memoranda No. 2580

April, 1947

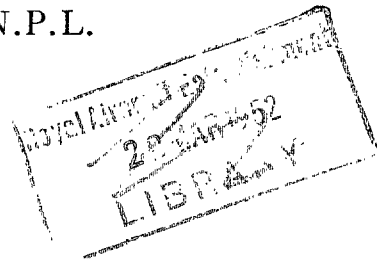

Summary.—Purpose of Ducting.—To provide uniform suction through a narrow slot along the span of a wing, with the lowest possible losses, when the pump is situated at the root of the wing.

Range of Investigation.—Models of various design were tested and modified in the light of the results obtained. From these experiments, together with a qualitative analysis of the flow through the type of ducting proposed, specific recommendations have been formulated for the attainment of uniformity of suction combined with low power losses.

Investigations were confined to suction from still air.

Results.—Losses of about $0.2q_1$ were obtained with the broad partition and with the guide-vane ducts, compared with about $0.7q_1$ for the earlier models, and the distribution of velocity at the slot was quite satisfactory. The circular collector duct appeared to be more efficient, but suction was much higher at the tip than at the root.

Future Developments.—Suction ducting is to be tested in the wall of a small wind-tunnel, so that the effect of the tunnel boundary layer may be studied.

1. *Introduction.*—Now that the principle of boundary-layer control by suction through slots has been firmly established, the question of providing efficient slot and ducting design is of critical importance, as this type of control is only likely to be worth while in practice if the power needed for suction is less than the power saved by improved flying characteristics.

The type of ducting investigated is that required to draw in air through a long narrow slot along the span of a wing, with the pump situated near the root. The flow has therefore to be turned through 90 deg and its cross-section changed from that of a fine slot to that of the exit duct.

Early Solutions.—In 'two-dimensional' model testing, and probably also in untapered parts of flying wings, uniform spanwise distribution of suction is essential. Originally this ideal has only been very remotely approached by diffusing the flow of air rapidly across the slot into a large rectangular suction chamber. Unfortunately it was never possible to make this chamber large enough to produce a good distribution of suction, and attempts were made to even out the flow with varying thicknesses of gauze, or by somewhat arbitrarily designed guide vanes (Fig. 1a).

One of the main disadvantages of the rectangular box design was the pronounced venturi effect produced by the contraction of the streamlines into the exit channel, which caused far greater suction at the near end of the slot than at the far end, and was hardly affected by any adjustment of the guide vanes.

In early tests in the 13 × 9 ft wind tunnel, tests at high lifts were limited to wind speeds of 40 to 60 ft/sec, because the high rates of flow in the ducting, associated with high lifts, caused a loss of head at entry and in the ducting which was too great for the suction pump to overcome.

The space available in later models was even more limited than before, because suction was applied over the whole span of the wing (not merely a four foot centre-section). Large settling chambers inside the wing were therefore entirely out of the question.

Thus, research on suction duct design was necessary to ensure uniform suction along the span, maximum economy of space and minimum duct losses.

2. *Form of Ducting.—Basis of Design.*—In the design of the test models of suction ducting, the dimensions of the slot are governed by the aerofoil boundary-layer conditions, and the maximum allowable area of the collector duct by the cross-sectional area and shape of the aerofoil. The velocity through the slot is high (200 to 300 ft/sec), so this must be reduced inside the wing to reduce friction losses. As a basis for design it was decided to carry out the full expansion immediately after entry while the duct boundary layer is still very thin, and then to turn the flow, by some form of guide vanes, into the collector stream. (See Figs. 2 and 3).

The Guide Vanes, or Partitions.—In order to cut the corner losses, the partitions, which were necessary in the first place to support the upper part of the frame and prevent the slot from closing, were shaped to change the exits of the tributaries from horizontal to vertical rectangular sections.

Altogether, the partitions were to serve four purposes:—

- (1) To support the frame and prevent the slot from closing,
- (2) To regulate diffusion in the tributaries,
- (3) To change a series of horizontal sections into a series of vertical sections,
- (4) To prevent oblique flow through the slot.

There are many ways in which the partitions might be designed, the best of which can only be found by trial and error. The solution is dependent not only on aerodynamic considerations, but also on the mechanical strength of the structure, ease of manufacture, and choice of material, *e.g.*, sheet or tubular metal design would certainly differ in detail, if not in general outline, from solid wood construction.

In large scale wind-tunnel models, wood is the most convenient material available, and it is this consideration which has contributed very largely to the designs described below, the forms chosen being simple to construct, while giving firm support within the wing.

The Collector Duct.—The design of the collector was relatively simple. In every model this was chosen to give a constant velocity field throughout, the velocity being equal to the velocity in the tributary bends. In this way it was hoped to reduce shock and friction losses in the collector to a minimum, and proved to be the least troublesome part of the models.

3. *Qualitative Analysis of Ducting Problem.*—The following analysis is of a qualitative nature only, but it does serve to bring out certain features of the design. The symbols are set out on page 9.

(i) *Local Distribution—Flow through Tributaries.*—The curvature of the streamlines, depicted in Fig. 4, results in a transverse pressure gradient across the tributaries, giving higher suction at the centres of the tributaries than by the leading edges of the partitions (the 'spurs'). A graph of velocity distribution through the slot shows corresponding maxima and minima.

These 'ripples' in the velocity curves can be reduced in the following ways:—

(a) *Sharpness of Spurs.*—The spurs should be sharp, and narrow, as the transverse pressure gradient is proportional to 2α , the angle of the spurs. A blunt leading edge gives a very steep, local drop of velocity through the slot, while a cusped leading edge would be ideal if it could carry the structural loads imposed on it. A useful compromise is to take $\tan \alpha \approx \frac{1}{3}$.

(b) *Spacing of Spurs.*—The greater the number of spurs, the smaller become the local pressure variations along the slot. The number is limited by the necessity for keeping skin friction losses low, and the consideration that a certain amount of ripple can be tolerated. A spacing of about 10 per cent. of the chord of a wing has so far been found to be quite satisfactory.

(c) *Diffusion before Spurs.*—As much diffusion as possible should be carried out before the flow reaches the spurs, provided this diffusion is not so much as to cause heavy duct losses.

(d) *Interval from Throat to Spurs.*—Referring again to the figure it will be seen that, proceeding upstream from the spurs, the streamlines tend to become parallel. Hence the further downstream from the slot the spurs are situated, the smaller will be the variations of velocity along the slot.

(e) *Separation from Lip.*—When diffusion after the slot entry is too rapid, or the entry is badly shaped, the flow breaks away from the slot lip, and a 'dead air' region is formed between the main stream and the diffuser beds. Through this region fluid is transferred from sections at high pressure and low velocity to sections at low pressure and high velocity. When this occurs, the influence of the spurs on velocity distribution is destroyed, but unfortunately the flow becomes unsteady and unstable, and suffers very high losses. An experiment in the control of this effect is described later.

(ii) *General Distribution.*—If the static and dynamic pressures are p_2 and q_2 at the lip of the collector, and $p_2 + \Delta p_2$ and $q_2 + \Delta q_2$ at the root, then

$$\begin{aligned} p_2 + q_2 + Cq_1 &= 0 \text{ (atmospheric datum)} \\ &= p_2 + q_2 + Cr^2q_2 = p_2 + q_2 (1 + Cr^2) \end{aligned}$$

where C is the tributary loss coefficient, with respect to q_1 . Similarly

$$\begin{aligned} (p_2 + \Delta p_2) + (q_2 + \Delta q_2) (1 + Cr^2) &= 0 \\ \therefore \Delta p_2 &= - \Delta q_2 (1 + r^2C). \end{aligned}$$

But
$$\Delta p_2 = - cq_2,$$

where c is the collector loss coefficient with respect to q_2 .

Hence
$$cq_2 = \Delta q_2 (1 + r^2C)$$

and the overall variation
$$\frac{\Delta q_1}{q_1} = \frac{\Delta q_2}{q_2} = \frac{c}{1 + r^2C}.$$

This expression shows that the overall variation can be made small in three ways:—

(a) *The Effect of the Overall Expansion Ratio r .*—If the slot width is very small, then the variation can be reduced by having a large expansion to the collector. As a rule, however, the cross-sectional area of wing available for ducting is not much larger than the area of the slot, but an expansion ratio of at least 2 should be achieved if possible.

(b) *The Influence of The Tributary Loss Coefficient C .*—In earlier forms of ducting great use was generally made of the fact that a fair distribution of suction can be achieved by making C very high, the flow through the slot being made to expand suddenly to a large settling chamber, and the slot being almost choked with gauze. The losses accompanying such methods are prohibitive, and the purpose of this report is to show that a good distribution can be achieved with less drastic methods.

(c) *The Influence of the Collector Loss Coefficient c .*—This is the most important factor in obtaining good general distributions, and the following are the means whereby a low value for c can be attained:—

- (1) The mean depth of the collector: the ratio of the cross-sectional area to the perimeter should be as large as possible, *i.e.*, for a rectangular cross-section, the mid-section should, ideally, be square.
- (2) The friction of the walls: the walls should be smooth.
- (3) The partition trailing edges: these should be cusped, very thin, and extended in a straight line a short way downstream. This last provision allows the radial pressure gradients in the bends to settle down before entering the collector.
- (4) The bends: disturbances arising from secondary flow in the bends can be reduced by making the radius/width, and the height/width ratios large.

(iii) *Losses.*—The most important losses occurring in ducting of this kind are diffuser, corner and friction losses. If, as is recommended, diffusion is carried out immediately after entry, the comparatively small dynamic pressure in the rest of the ducting makes losses from friction, bends, and changes of cross-sectional shape of only secondary importance. The efficiency of the whole rests primarily, therefore, on the efficiency of the diffuser, and the shape of the entry.

The region just in front of the tributaries forms a simple two-dimensional diffuser, and for optimum conditions the slope of the beds should be slightly less than 1 in 10, 1 in 12 probably being the safest value to take.

The shape of the entry is very important, as breakaway from the lip completely spoils the characteristics of the diffuser. The curvature of the entry should decrease continuously to merge with the straight beds of the diffuser, otherwise premature separation occurs. The 'free streamline' entry shape appears to be very satisfactory when drawing on still air, but it is not yet known what happens with moving air, especially with a discontinuity of velocity in the external stream.

The losses in a well shaped entry and diffuser are found to be about double all the other losses in the ducting up to the root of the collector.

(4) *Experimental Development of Duct Design.*—Various designs were tested on the model scale by measuring the spanwise distribution of velocity at the slot entry. It was not possible to measure this velocity by means of a normal Booth tube, because of the rapid changes taking place along the entering streamlines, nor could a simple pitot-static tube be used, because this would have to be manipulated from within the model and would interfere with the internal suction. Consequently it was found necessary to use a form of reversed total head tube, similar to the downstream part of a Booth tube.

Initially a fine bore cylindrical tube was used, but was found to give very inconsistent results. It was extremely sensitive to the angle at which it was held (relative to the streamlines), the distance it penetrated into the slot, and to its distance from the slot walls.

Finally a more satisfactory form of probe was made from $\frac{1}{4}$ in. external diameter brass tubing, the end of which was flattened and filed down to form a fine slit completely bridging the slot. The angle and the depth of penetration were controlled by small fins which fitted closely against the slot entry (Fig. 1b). The probe was linked by rubber tubing to a U-tube reading up to 3 ft of water.

The probe gave a measure of the mean dynamic head across the slot, at a fixed distance within the slot. As it was only needed to detect variations in the spanwise distribution of suction, it was not calibrated against any absolute scale. The tests were done with slot velocities from 200 to 300 ft/sec. There was no noticeable scale effect over this range. The slot widths were of the same order as might be expected on a full-scale wing.

Presentation of Results.—Neglecting duct losses, the equations of energy and continuity give:—

$$p_1 + \frac{1}{2}\rho u_1^2 = p_2 + \frac{1}{2}\rho u_2^2 = 0,$$

(since the experiments draw on static air ($u = 0$) at atmospheric pressure ($p = 0$)),

$$\text{and } u_1 = ru_2$$

$$\text{Therefore } p_1 = r^2 p_2.$$

The finite losses of the duct make the ratio $p_1/r^2 p_2$ less than 1, and this ratio is termed the static pressure efficiency of the duct. Again neglecting losses,

$$q_1 = -p_1 = -r^2 p_2.$$

In practice the ratio $-q_1/r^2 p_2$ is also less than 1 and is termed the dynamic pressure efficiency.

In a free streamline entry, it is found that $q_1 \simeq -0.9p_1$.

The ratio of the real velocity to the ideal, v_1/u_1 , is termed the velocity efficiency, and is equal to $\sqrt{(-q_1/r^2 p_2)}$,

$$\text{for } \frac{1}{2}\rho u_1^2 = r^2 \frac{1}{2}\rho u_2^2 = -r^2 p_2$$

$$\text{and } \frac{1}{2}\rho v_1^2 = q_1.$$

With a free streamline entry again,

$$\frac{v_1}{u_1} = \sqrt{\left(\frac{-q_1}{r^2 p_2}\right)} \simeq 0.95 \sqrt{\left(\frac{-p_1}{r^2 p_2}\right)}.$$

A valuable comparison of the performance of different types of ducting is obtained by measuring the static pressure along the throat of the slot, p_1 , and in the collector root, p_2 , and plotting on a graph the spanwise distribution of $\sqrt{(p_1/r^2 p_2)}$. The graph shows immediately both the distribution of velocity, and the efficiency of the ducting. The highest value of $\sqrt{(p_1/r^2 p_2)}$ so far attained is 0.93.

5. Sixteen Tributary Duct. Fig. 5.—Slot dimensions: $48 \times \frac{1}{4}$ in.

The region before the spurs consisted of a free streamline type of entry, followed by the optimum diffuser. The beds of the diffuser were then continued in a straight line till an expansion ratio of 2.5 was reached in the tributaries, then they were curved to continue this expansion ratio of 2.5 to the collector. In this way the concavity* encountered in the guide vane duct was eliminated so that premature turbulence in a rather critical region of the ducting was avoided.

As the losses in the tributaries were relatively low, it was expected that the velocity would fall off rather badly towards the tip, but the distribution was in fact found to be quite good. The slight fall-away was more than compensated by the fact that the losses were reduced from about $0.7q_1$ in the original form, to about $0.185q_1$ and the inflow was far steadier.

From pressure measurements taken along the tributaries it was estimated that 10 per cent of the losses occurred before the throat, a further 50 per cent. up to the spurs, 6 per cent to the beginning of the curved tributary bed, while the rest of the losses—34 per cent—occurred in the bends and collector.

* A boundary layer is unstable on a concave surface.

As these tests were made on an old model in which only the beds had been modified, not all the conditions necessary for efficient collection were satisfied. A further improvement of distribution could be achieved by fuller application of the recommendations in the analysis.

Graded throttling.—In one of the early models a test was made with a simple form of graded throttling, with the object of eliminating the overall spanwise variation in the suction flow. The results were highly satisfactory.

The throttling device consisted of a long strip of brass, set in a sawcut running across all of the partitions. The ends of the strip were supported so that its depth of penetration into the tributaries could be adjusted by moving either end.

This method of throttling is recommended as a supplementary device for obtaining level distribution of suction, because it regulates the flow through each channel simultaneously. Other methods had been tried in some early models, in which only one channel had been throttled at a time. But this was found to be highly unsatisfactory, as changes in one channel always upset the flow in neighbouring channels.

This type of throttle is extremely simple to adjust, and is particularly suited for use in wind-tunnel models because it is not necessary to have access to the throttle through the surface of the wing. It can of course be used to obtain any other form of distribution and not just the level distribution aimed at in these tests.

Alternatively the overall distribution can be improved by gauzes, but this method is not recommended, because of the extra losses it introduces.

6. *Slot with Vortex Channels.*—During the successive modification of tributary section shape in a small two-tributary duct (Fig. 6) it was found that the velocity distribution could be levelled very effectively by means of two vortex channels running spanwise along the slot throat (Section C of Fig. 6). The spanwise variation of velocity was extremely small—about 2 per cent—and the flow so steady that the liquid in the manometer appeared to be almost rigidly fixed while observations were being taken. Unfortunately, the idea appears so far to be impractical as the channels give out a very piercing whistle. This was reduced considerably by rounding off the rear edge of the channel, and if the whistle can be eliminated altogether by more careful design, then the channels should have quite wide application.

7. *Guide Vane Duct (Figs. 7 and 8).*—The idea of using guide vanes has always appeared attractive because of their simplicity of construction and assembly, their lightness and compactness. So, taking advantage of experience gained with other ducting, a small model was built for comparison.

Design.—Slot dimensions: $12 \times \frac{1}{4}$ in.

Number of tributaries: 4.

Expansion to collector: $r = 2$.

All the expansion was carried out before the guide vanes at the optimum rate of diffusion (slope of beds = 1 in 10). The entry was roughly of free streamline shape modified to join smoothly with the sloping beds of the diffuser. The entry and diffuser together occupied a length of only 6 slot widths, *i.e.*, $1\frac{1}{2}$ in.

The curve chosen for the shape of the guide vanes was an oblique parabola, as the curvature thereof decreases towards the trailing edge, allowing a less sharp divergence of the tributary beds than would be the case with circular arcs. The graphical construction for, and the analytical treatment of this type of curve is relatively simple. However, in retrospect, circular vanes would probably have been better, as they would give a smaller initial radial pressure gradient across the tributaries, and would provide a length of relatively tranquil flow beyond the diffuser in which some of the diffuser pressure loss could be recovered.

The depth of the tributaries was calculated on the assumption that the streamlines follow the same curve as the vanes, so that the width of a stream tube at any point is proportional to the cosine of the angle between the tangent at that point and the tangent at the leading edge; the depth, therefore, for constant area of cross-section, varies as the secant of this angle.

Testing.—Static pressure readings were taken at the slot throat at points opposite the vanes, and half way between. Intermediate points on the graph were interpolated from a series of observations taken with a probe.

The graph shows that the efficiency and distribution of velocity compare very well with other models, the loss coefficient being 0.215. It also shows that the radial pressure gradient between the vanes gives a slightly higher velocity opposite the convex side than the concave side. This effect could be reduced by spacing the vanes more closely, reducing the initial curvature, or adding straight extensions to the leading edges.

The flow through the slot was observed by means of smoke filaments. The flow appeared to be laminar, in the diffuser, but turbulenced at the concavity formed by the junction of the tributary and diffuser beds. When the smoke was directed at the leading edge of a vane, it followed both the convex and concave sides very closely, showing no sign of separation from either side.

Thus guide vanes appear to be very suitable for suction slot ducting, the only disadvantages being that they do not provide the same degree of support, nor do they offer as much space between the tributaries in which to accommodate the ribs and spars of a real wing, as do the broad partitions.

8. *Vortex Collector Duct.* (Fig. 9).—Slot dimensions: $48 \times \frac{1}{4}$ in. Overall expansion ratio: $r = 4.2$.

The duct shown in Fig. 9 was designed to have the flow through the slot passing tangentially into a collector of roughly circular cross-section.

Three different plan forms were tested. The first consisted of a simple frustum of a cone, the tip diameter being half the root diameter. In the second a solid cone was placed inside the frustum, the base coinciding with the tip of the frustum, and the apex coinciding with the centre of the root section. In the third, a parabolic cone was built, with one straight edge along the slot. The two latter designs gave a constant variation of cross-sectional area from tip to root, as with the rectangular collectors so far described.

This type of duct appeared to be very efficient, as higher suction was achieved than with any of the other ducts, though no quantitative estimate could be made of the losses without great difficulty, owing to the complexity of the exit conditions. Unfortunately, however, the distribution of suction was disappointing, as the entry velocity was far higher at the tip than at the root.

9. *Conclusion and Recommendations.*—In the light of the tests described above, and the preceding analysis, the following recommendations may be formulated for the design of ducting of high efficiency and good local and general distribution:—

(i) *For Good General Distribution*

(roughly in order of importance):—

- (a) The velocity field in the collector should be uniform.
- (b) All tributaries should be similar.
- (c) The velocity in the collector should be low compared with the velocity in the slot.
The expansion ratio should not be less than 2.

- (d) The spacing of tributaries should be fairly small: a spacing of about 10 per cent of the chord of a wing appears to be sufficient.
 - (e) The bend radius/width ratio should be large—greater than 3.
 - (f) The bend height/width ratio should be large—greater than 4.
 - (g) The trailing edges of the partitions should be sharp, cusped, and extended in a straight line a short way downstream—about 1 bend width if possible.
 - (h) The collector walls should be smooth.
 - (i) The mid-section of a rectangular collector should, ideally, be square.
 - (j) The collector should be continued in a straight line downstream as far as possible; otherwise the pressure gradients arising from the curvature of the stream can be reduced by a carefully designed cascade of guide vanes across the collector.
- (ii) *For Good Local Distribution.*—
- (a) Using the optimum diffuser, the depth of the slot at the leading edges of the spurs should be at least double the depth at the throat.
 - (b) The tangent of the semi-angle of the spurs should be less than $\frac{1}{3}$.
 - (c) The spurs should be well downstream from the throat. The optimum diffuser with expansion ratio $r = 2$ gives a length of 5 slot widths from throat to spurs. This length should be exceeded if possible.
 - (d) Blunt or rounded spurs must be avoided.
 - (e) The spacing of the spurs must be close.
 - (f) Vortex channels might be used if they can be effectively silenced.
- (iii) *For High Efficiency.*—
- (a) For optimum two-dimensional diffusion, the slope of the diffuser beds should be a little less than 1 in 10. This value is rather critical, so a value of 1 in 12 is recommended as being safer.
 - (b) A free streamline or other carefully designed entry should be used. Breakaway at entry can cause a rise of losses to $2 \cdot 0q_1$.
 - (c) Diffusion should be carried out as near the entry as possible, where the boundary layer is thinnest.
 - (d) The expansion ratio in the tributaries should nowhere be allowed to exceed the expansion ratio in the collector. The beds should therefore be convexly curved ahead of the bends.
 - (e) Duct walls should be smooth and all angles filled in or radiused off (except leading and trailing edges).
 - (f) Low loss coefficients in the bends and collector are important for good general distribution, but not very important as far as the overall efficiency is concerned, because the relevant dynamic pressures are relatively small.

LIST OF SYMBOLS

$2b$ Width of bend B Radius of bend d Slot width d_1 Height of tributary at leading edge of partitions D Height of tributary at bend r Expansion ratio: <i>i.e.</i> , ratio of duct area in collector to that at slot throat α Semi-angle of partitions.	$\left. \vphantom{\begin{array}{l} 2b \\ B \\ d \\ d_1 \\ D \\ r \\ \alpha \end{array}} \right\} \text{ See Fig. 3.}$															
<table style="width: 100%; border-collapse: collapse;"> <thead> <tr> <th style="width: 60%;"></th> <th style="text-align: center; width: 20%;"><i>At slot throat</i></th> <th style="text-align: center; width: 20%;"><i>In collector</i></th> </tr> </thead> <tbody> <tr> <td>Ideal velocity (no losses)</td> <td style="text-align: center;">u_1</td> <td style="text-align: center;">u_2</td> </tr> <tr> <td>Measured velocity (mean)</td> <td style="text-align: center;">v_1</td> <td style="text-align: center;">v_2</td> </tr> <tr> <td>Static pressure relative to atmosphere</td> <td style="text-align: center;">p_1</td> <td style="text-align: center;">p_2</td> </tr> <tr> <td>Dynamic pressure (mean)</td> <td style="text-align: center;">$q_1 = \frac{1}{2}\rho v_1^2$</td> <td style="text-align: center;">$q_2 = \frac{1}{2}\rho v_2^2$</td> </tr> </tbody> </table>		<i>At slot throat</i>	<i>In collector</i>	Ideal velocity (no losses)	u_1	u_2	Measured velocity (mean)	v_1	v_2	Static pressure relative to atmosphere	p_1	p_2	Dynamic pressure (mean)	$q_1 = \frac{1}{2}\rho v_1^2$	$q_2 = \frac{1}{2}\rho v_2^2$	
	<i>At slot throat</i>	<i>In collector</i>														
Ideal velocity (no losses)	u_1	u_2														
Measured velocity (mean)	v_1	v_2														
Static pressure relative to atmosphere	p_1	p_2														
Dynamic pressure (mean)	$q_1 = \frac{1}{2}\rho v_1^2$	$q_2 = \frac{1}{2}\rho v_2^2$														
$\sqrt{(p_1/r^2 p_2)}$ Velocity efficiency ignoring losses between slot entry and throat. (If these losses are taken into account, the actual velocity efficiency is approximately $0.95 \sqrt{(p_1/r^2 p_2)}$.)																

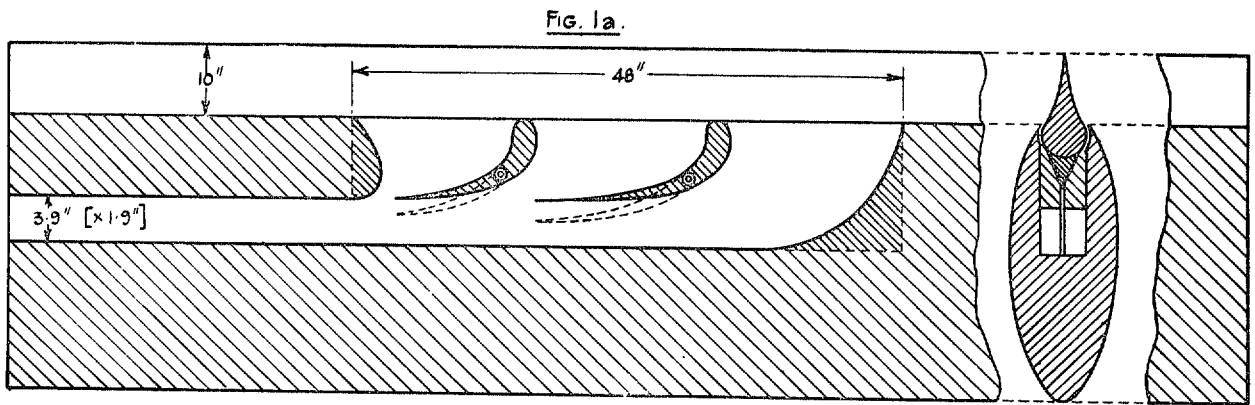
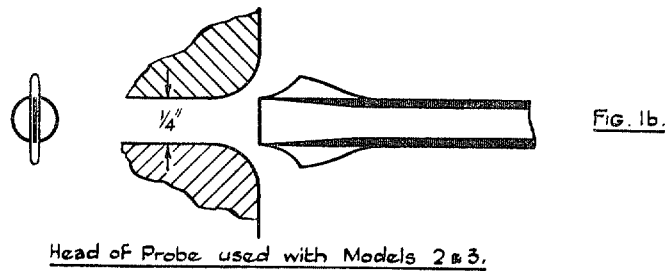

Fig. 1. Initial ducting of the 30 per cent Griffith wing.

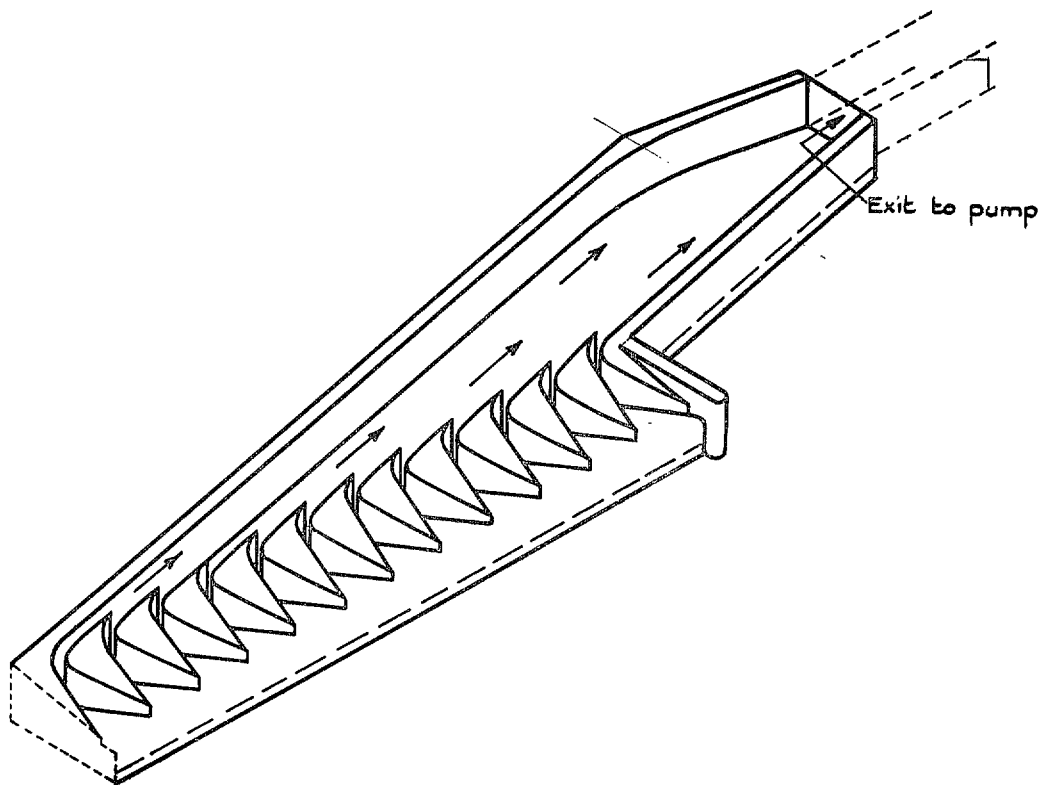
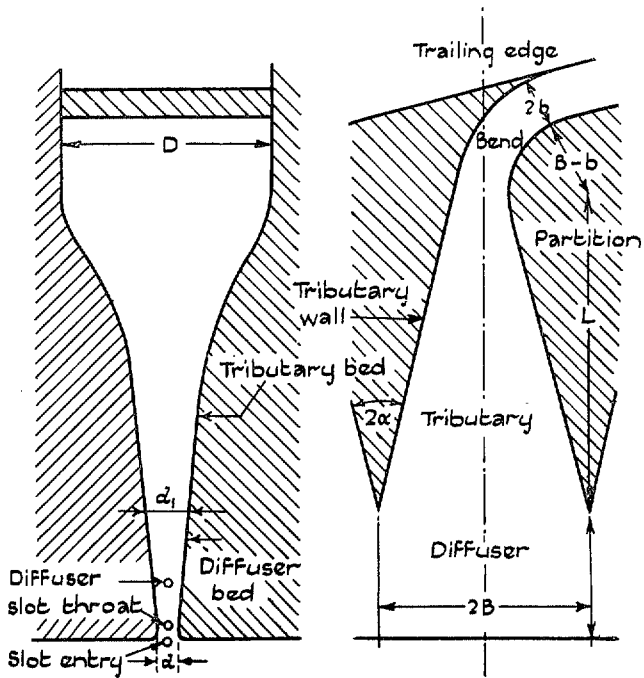
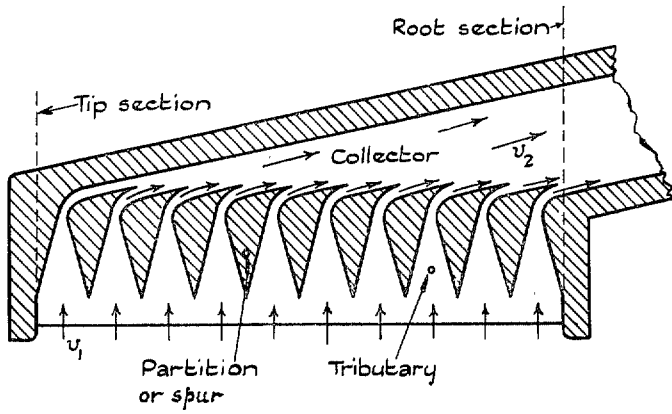

Fig. 2. Suggested form of internal ducting. Isometric view.



Section of Tributary

Plan of Tributary

Fig. 3. Nomenclature and dimensions.

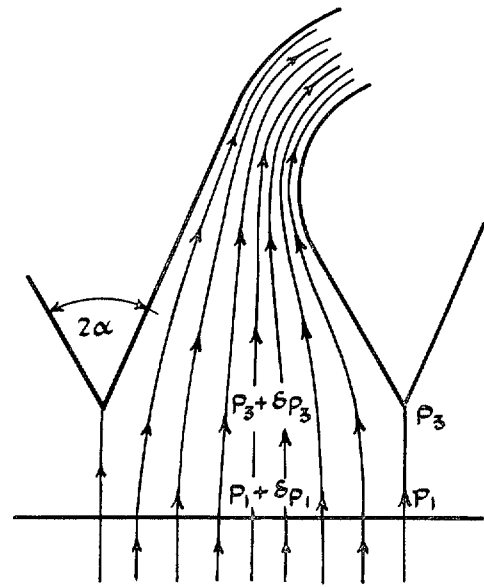

Fig. 4. Local flow through tributary.

Expansion ratio $\tau=2.5$

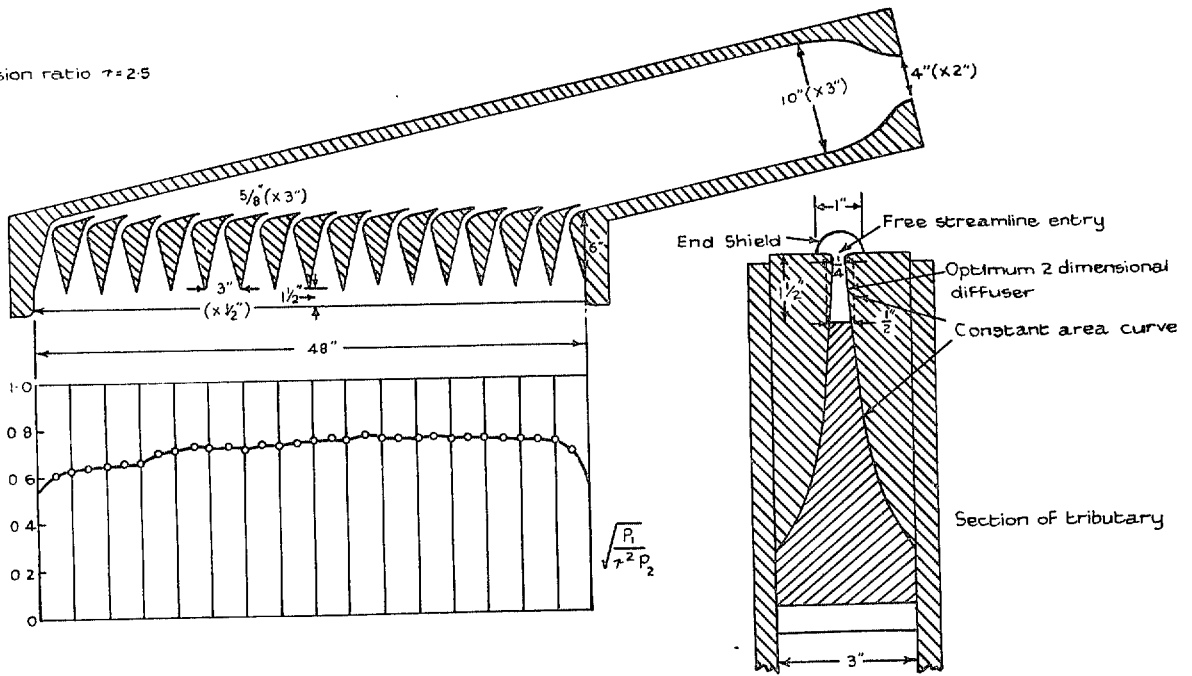

Fig. 5. Sixteen-tributary optimum-diffuser duct.

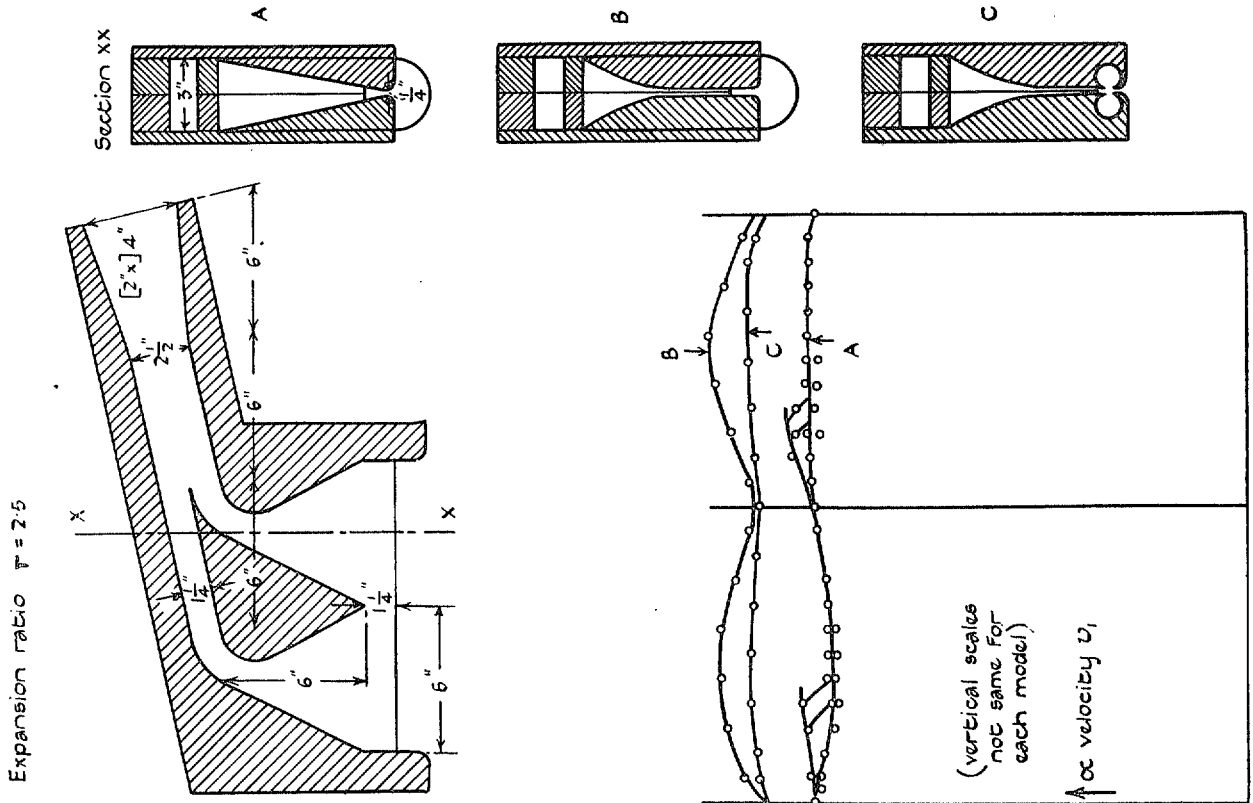

Fig. 6. Small two-tributary duct.

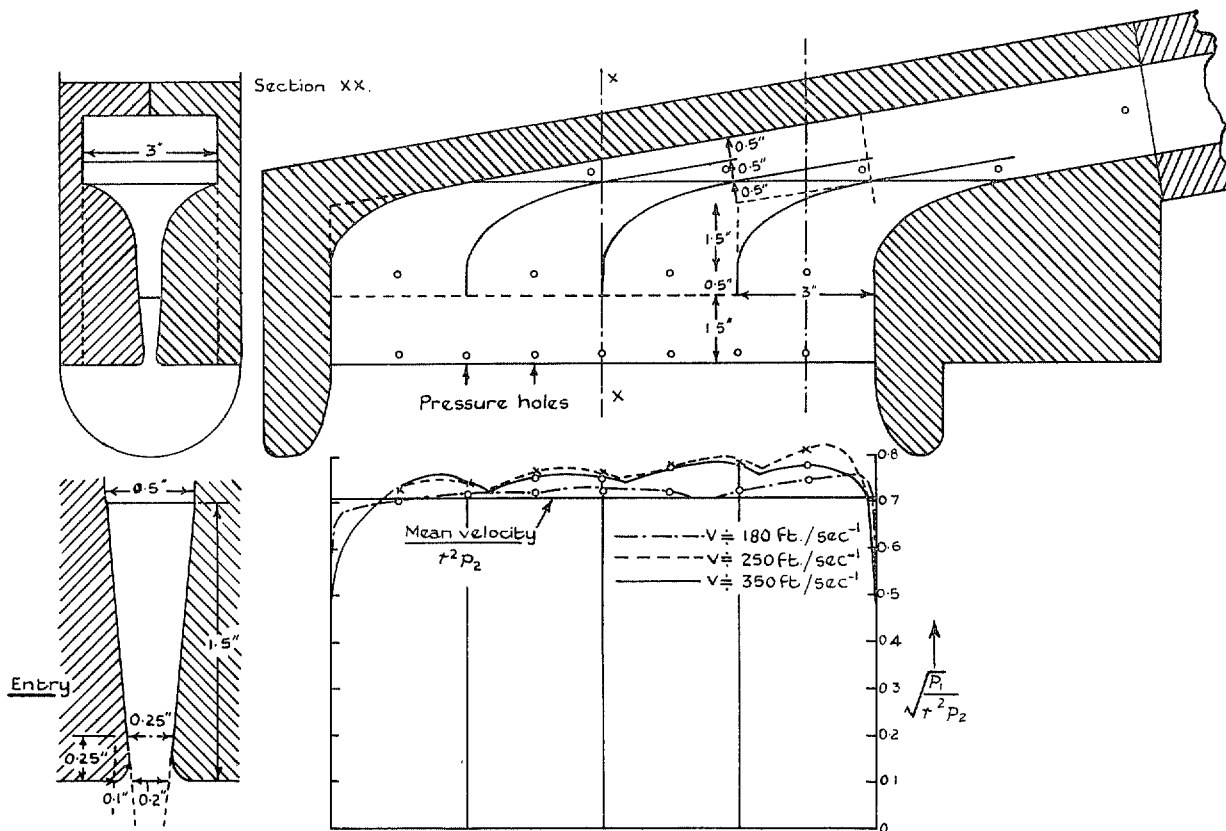

Fig. 7. Guide vane duct.

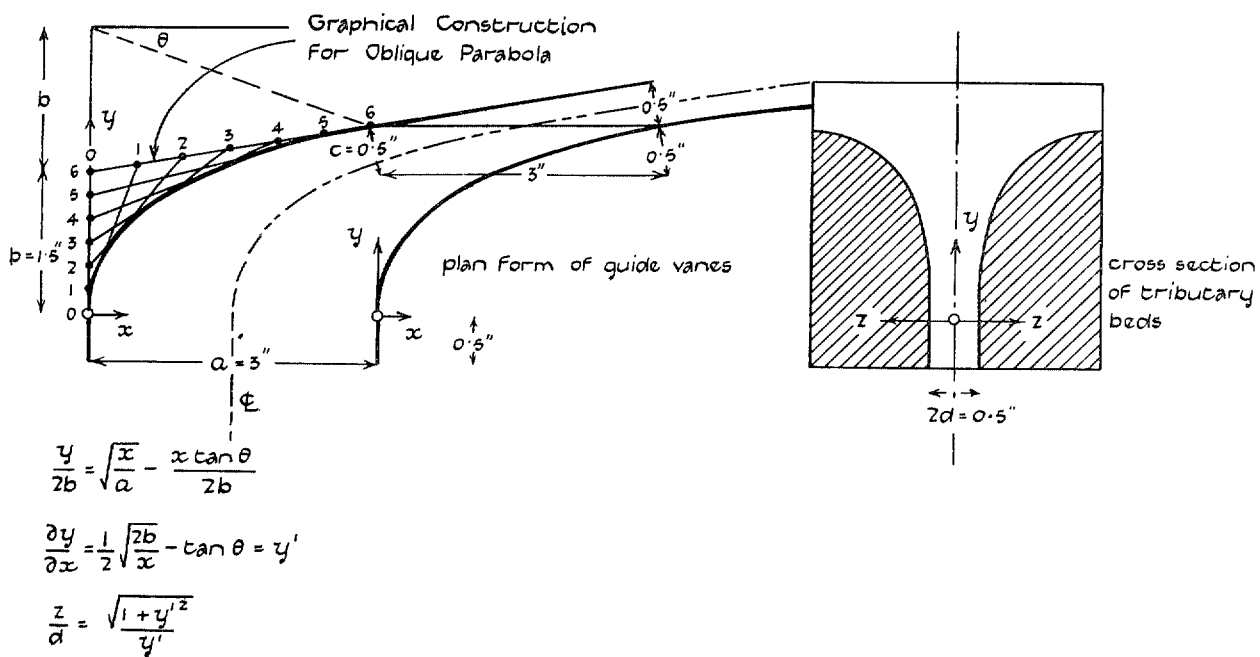

Fig. 8. Shape of guide vane tributaries.

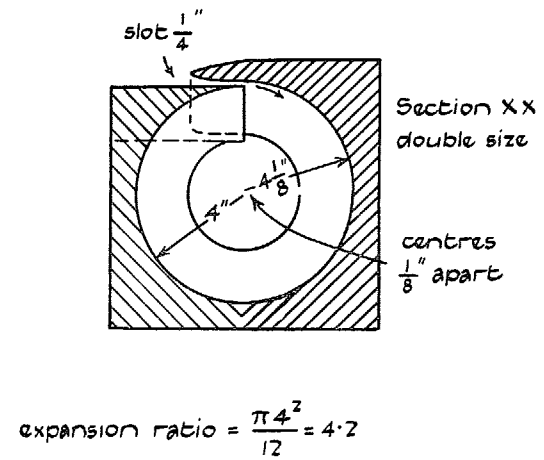
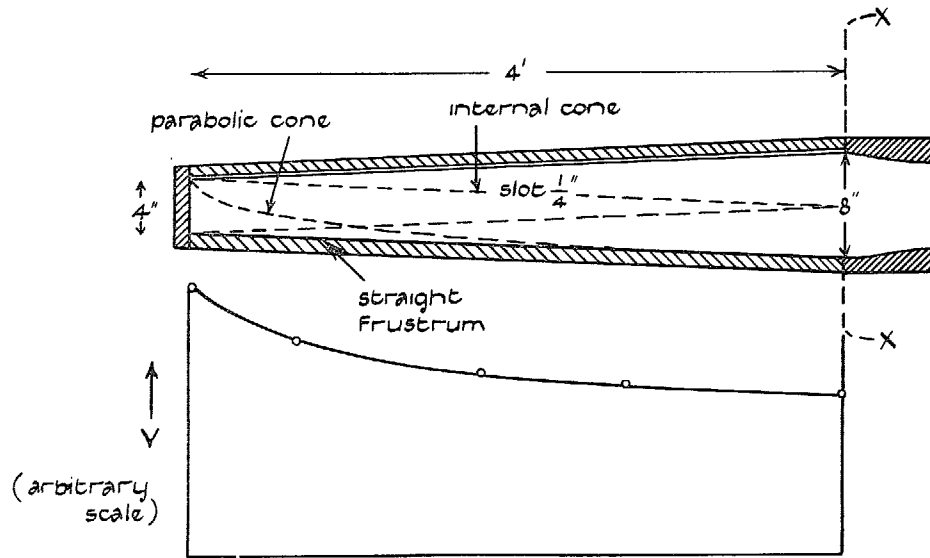

Fig. 9. Conical vortex duct.

Publications of the Aeronautical Research Council

ANNUAL TECHNICAL REPORTS OF THE AERONAUTICAL RESEARCH COUNCIL (BOUND VOLUMES)—

- 1934-35 Vol. I. Aerodynamics. *Out of print.*
Vol. II. Seaplanes, Structures, Engines, Materials, etc. 40s. (40s. 8d.)
- 1935-36 Vol. I. Aerodynamics. 30s. (30s. 7d.)
Vol. II. Structures, Flutter, Engines, Seaplanes, etc. 30s. (30s. 7d.)
- 1936 Vol. I. Aerodynamics General, Performance, Airscrews, Flutter and Spinning. 40s. (40s. 9d.)
Vol. II. Stability and Control, Structures, Seaplanes, Engines, etc. 50s. (50s. 10d.)
- 1937 Vol. I. Aerodynamics General, Performance, Airscrews, Flutter and Spinning. 40s. (40s. 10d.)
Vol. II. Stability and Control, Structures, Seaplanes, Engines, etc. 60s. (61s.)
- 1938 Vol. I. Aerodynamics General, Performance, Airscrews. 50s. (51s.)
Vol. II. Stability and Control, Flutter, Structures, Seaplanes, Wind Tunnels, Materials. 30s. (30s. 9d.)
- 1939 Vol. I. Aerodynamics General, Performance, Airscrews, Engines. 50s. (50s. 11d.)
Vol. II. Stability and Control, Flutter and Vibration, Instruments, Structures, Seaplanes, etc. 63s. (64s. 2d.)
- 1940 Aero and Hydrodynamics, Aerofoils, Airscrews, Engines, Flutter, Icing, Stability and Control, Structures, and a miscellaneous section. 50s. (51s.)

Certain other reports proper to the 1940 volume will subsequently be included in a separate volume.

ANNUAL REPORTS OF THE AERONAUTICAL RESEARCH COUNCIL—

- 1933-34 1s. 6d. (1s. 8d.)
1934-35 1s. 6d. (1s. 8d.)
April 1, 1935 to December 31, 1936. 4s. (4s. 4d.)
1937 2s. (2s. 2d.)
1938 1s. 6d. (1s. 8d.)
1939-48 3s. (3s. 2d.)

INDEX TO ALL REPORTS AND MEMORANDA PUBLISHED IN THE ANNUAL TECHNICAL REPORTS, AND SEPARATELY—

- April, 1950 R. & M. No. 2600. 2s. 6d. (2s. 7½d.)

INDEXES TO THE TECHNICAL REPORTS OF THE AERONAUTICAL RESEARCH COUNCIL—

- December 1, 1936 — June 30, 1939. R. & M. No. 1850. 1s. 3d. (1s. 4½d.)
July 1, 1939 — June 30, 1945. R. & M. No. 1950. 1s. (1s. 1½d.)
July 1, 1945 — June 30, 1946. R. & M. No. 2050. 1s. (1s. 1½d.)
July 1, 1946 — December 31, 1946. R. & M. No. 2150. 1s. 3d. (1s. 4½d.)
January 1, 1947 — June 30, 1947. R. & M. No. 2250. 1s. 3d. (1s. 4½d.)

Prices in brackets include postage.

Obtainable from

HER MAJESTY'S STATIONERY OFFICE

York House, Kingsway, LONDON, W.C.2 429 Oxford Street, LONDON, W.1
P.O. Box 569, LONDON, S.E.1
13a Castle Street, EDINBURGH, 2 1 St. Andrew's Crescent, CARDIFF
39 King Street, MANCHESTER, 2 Tower Lane, BRISTOL, 1
2 Edmund Street, BIRMINGHAM, 3 80 Chichester Street, BELFAST

or through any bookseller.