

C.P. No. 186

(15,980)

A.R.C. Technical Report

C.P. No. 186

(15,980)

A.R.C. Technical Report



MINISTRY OF SUPPLY

AERONAUTICAL RESEARCH COUNCIL

CURRENT PAPERS

Load Diffusion in Plastic Structures

By

L. M. Tucker and R. B. Twiss

LONDON: HER MAJESTY'S STATIONERY OFFICE

1955

Price 8s. 6d. net

ROYAL AIRCRAFT ESTABLISHMENT

Load diffusion in plastic structures

by

L.M. Tucker
and
R.B. Twiss

SUMMARY

This report describes theoretical and experimental investigations of the inherent advantages, in plastic structures, of resin bonded shear joints over comparable pin joints, and the most efficient material distribution for load diffusion.

Loads of over 50 tons in tension and compression have been achieved by the bonding of steel inserts into vacuum moulded, chrysotile asbestos-reinforced phenolic resin panels, with an efficiency 50% of the theoretical ideal diffusion panel.

Satisfactory strength characteristics were shown over the temperature range -80°C to $+90^{\circ}\text{C}$, with a drop of about 20% immediately after wetting and exposure and with consistent failure in the plastic, not in the glue joint.

Variations of moulding technique had small effect on strength compared with correct choice of materials, splice proportions, span and sharpness of inserts; factors which are most important for high load capacity.

Theoretical analysis and graphical solutions are developed to obtain the ideal distribution of material for load diffusion; these have general applicability to structural design problems.

It is believed that by careful design and manufacture, very high diffusion and joint efficiencies can be realised.

LIST OF CONTENTS

	<u>Page</u>	
1	Introduction	7
2	Initial experiments	8
2.1	Glued inserts in simple test panels	8
2.11	Inserts	8
2.12	Test panel construction and assembly	9
2.13	Gluing	9
2.14	Vacuum moulding	9
2.15	Mechanical testing	10
2.2	Relative efficiencies of insert shapes	10
2.21	Tapering to narrow point in both planes	10
2.22	Parallel flat strips	10
2.23	Fishtail; increased span, reduced insertion depth	11
2.3	Effect of panel thickness on insert failure	12
3	Four inch span fishtail inserts in plain Durestos panels under various conditions	16
3.1	Comparative glue tests at normal temperatures	16
3.11	Effect on insert failing loads of wetting prior to vacuum moulding	16
3.12	Effect of pre-pressing on strength	19
3.2	Effect of temperature on load capacity	19
3.3	Deterioration	22
3.31	Water immersion	22
3.32	Climatic exposure	22
4	Inserts up to 20 inch span with panel contouring for diffusion of point loads up to 50 tons	24
4.1	Inserts of from 7 in. to 9 in. span in contoured panels	24
4.2	Contouring with stress pattern interplotting for improved stress distribution	25
4.3	Assembly and vacuum moulding of large insert test panels	27
4.4	Ventilation of glued joints with metal inserts	28
4.5	Loading tests with inserts of 20 inch span	29
4.6	Some factors influencing load capacity	30
5	Interpretation of experimental results	30
5.1	General load characteristics of steel inserts in vacuum-moulded Durestos, from experimental results	30
5.2	Efficiency criterion for insert test panels	33
6	Theoretical analysis of load diffusion	35
6.1	Analysis of load diffusion in plane panels	35

LIST OF CONTENTS (CONTD)

	<u>Page</u>
6.11 Influence of material on stress distributions	35
6.12 Failure under combined stress	36
6.13 Geometry, material properties, and stress relationships	36
6.14 A concentrated load acting on a boundary of a semi-infinite plate	37
6.15 Uniformly distributed load acting on a boundary of a semi-infinite plate	37
6.16 Analysis of opposed point loads and the formation of a combined stress pattern	37
6.17 Opposed uniformly distributed loads	38
6.18 Application of stress patterns	
(a) to laminated plastics	38
(b) to metal inserts	39
6.19 Conclusions	40
6.2 Analysis through the thickness of the panel at joints between plastic and metal	40
6.21 Types of adhesive joint	40
6.22 Stress distribution along the length of the joint	40
6.23 Stress distribution in joints between two materials of different elastic moduli	40
6.24 Types of insert	41
7 Materials for load diffusion	41
7.1 Mechanical properties of materials to be joined. Metals compared with Durestos	41
7.2 Properties of Durestos	42
7.3 Application of Durestos to panels with inserts	42
7.31 In the plane of the panel	42
7.32 In the thickness of the panel	42
7.4 Effect of thermal expansion on stress between different materials	43
8 Point attachments for large plastic structures	43
8.1 Applications to the plastic wing	43
8.2 Insert packs for sub-assembly	44
8.3 Location of inserts during vacuum moulding	44
9 Recommendations for future work	44
9.1 Basic information on material physical properties	44
9.2 Use of new materials	44
9.3 Diffusion of even larger point loads	45
9.4 Further work	45
10 Conclusions	45
Acknowledgement	46
References	46

LIST OF APPENDICES

	<u>Appendix</u>
Rate of loading of insert test panels	I
Large span steel inserts	II

LIST OF TABLES

	<u>Table</u>
Glued inserts: span increase, insertion decrease	I
Panel thickness: effect on failing load	II
Glue comparison	III
Average failing loads in tons of glued inserts with and without sealing coats	IV
Effect of wetting before cure	V
Effect of glue variation on failing loads at 90°C	VI
Effect of temperature on insert load capacity	VII
Deterioration	VIII
7-9 inch span fishtail inserts in asymmetrically-contoured panels	IX
20 inch span fishtail inserts in asymmetrically-contoured panels	X
20 inch span inserts in contoured symmetrical panels	XI
Panel efficiency	XII
Typical panel and insert weights	XIII
Rates of loading	XIV Appendix I

LIST OF ILLUSTRATIONS

	<u>Figure</u>
Progressive development of insert shapes	1
Good and imperfect adhesion	2A
Variation of effective insertion depth	2B
Typical failures 4" span insert panels	3 A, B, C, & D
Shear failure at 9.3 tons of a 4" span insert compression panel	4

LIST OF ILLUSTRATIONS (Contd)

	<u>Figure</u>
Shear failure at 22.5 tons of 9.38" span insert compression panel	5
Reverse side of insert	6
20" span fishtail insert profile-machined with 1° nose angle	7
Panel assembly showing introduction of glued inserts	8
Contoured felt assembly completed	9
20" span insert: Well ventilated top surface	10A
20" span insert: Badly ventilated bottom surface	10B
20" span insert: Good ventilation, top surface	11A
20" span insert: Good ventilation, under surface	11B
Asymmetrically contoured test panel - plan view	12
Asymmetrically contoured test panel - side view	13
20" insert test panel: Failure at 52 tons (contoured side)	14
20" insert test panel: Shear and tension failure at 52 tons (plain side)	15
20" insert compression panel showing stabilisation and end fixation (plan view)	16
20" insert compression panel showing stabilisation and end fixation (side view)	17
Completely symmetrical panel with failed insert	18
Load characteristics of steel inserts in vacuum-moulded Durestos from experimental results	19 and 20
Ideal adhesive joint between similar materials	21
Ideal adhesive joint between two materials of different elastic moduli	22
Typical section through joint as used in 20" span insert test panel and Delta plastic wing	23
Concentrated load acting on a semi-infinite plate Principal stress trajectories	24
Stress pattern	25
Section of stress pattern on centre line	26

LIST OF ILLUSTRATIONS (Contd)

	<u>Figure</u>
Uniform Load acting on a semi-infinite plate Principal Stress trajectories	27
Stress pattern	28
Section of stress pattern on centre line	29
Opposed point-loads on a circular panel Principal stress trajectories	30
Stress pattern	31
Section of stress pattern on centre line	32
Opposed uniformly-distributed loads Principal stress trajectories	33
Stress pattern	34
Section of stress pattern on centre line	35
Comparison of stress-strain curves of various steels with that of Durestos	36
Comparison of stress-strain curves of aluminium and magnesium alloys with that of Durestos	37
Durestos tension properties through the thickness for all angles of loading	38
Plan view of top skin of plastic Delta wing showing inserts and lines of constant skin thickness	39
Section through wing showing internal web structure and root forgings	40
Sub-assembled insert packs for plastic Delta wing	41

1 Introduction

High strength inserts and joints, capable of sustaining tension or compression loads of the order of 40-50 tons or more, economical in weight and as compact as possible in size, were needed for plastic structures requiring diffusion of point-loads; in particular, root fittings for plastic wings.

Little information on such inserts could be found in the literature, though it is common practice to mould them under high pressure, but without gluing, into many commercial plastic materials. Such inserts are frequently notched or serrated to give a mechanical "key"; efficient load carrying is generally of secondary importance provided strength is adequate for the required purpose.

A glued joint of adequate area between a metal insert and a plastic structure provides potentially the best method of distributing large concentrated loads, and it is to this end that the present investigation has been directed.

Ad hoc experiments had indicated that a fair molecular bond between steel and phenolic (P.F.) resin could be achieved by the simple introduction of clean steel inserts between sheets of Durestos* subsequently cured by the R.A.E. vacuum moulding process¹. In the absence of additional glue, however, adhesion was unreliable and strength insufficient. Other inter-dependent factors not at all obvious at the time are now known greatly to influence joint strength.

A step-by-step approach seemed the only feasible method of investigation, but even so, all variables could not, with available resources, be dealt with completely or entirely selectively. The ideal would be statistical investigation of much larger numbers of many sizes and types of joint under the range of conditions necessary for aircraft structural materials.

However, joints made under closely similar conditions have shown better reproducibility than expected, the strength characteristics being much the same as those of the plastic itself.

Though no size limitation has been discovered, larger-scale investigations proved more difficult in practice, chiefly because of increase in manufacturing difficulties in attempting to approach the theoretically ideal linear relationship between load capacity and depth of insertion.

A practical difficulty also arises in attempting to simulate point load diffusion into a semi-infinite skin or panel structure; semi-infinite that is compared with insert dimensions. Ultimately a truly representative test specimen can only be the completed structure itself; this is especially so for a plastic wing with point attachments, because the stress distribution is even less determinate than in wings of orthodox construction. Where many tests are necessary, test panels of reasonable sizes with two opposed inserts prove the best method of experimental load diffusion. These do not behave however as a semi-infinite panel containing one insert only from the stress viewpoint, particularly when inserts are large compared with panel size.

For a closer approximation to the ideal state of plane diffusion, interplotting of theoretical stress-patterns for each insert, with subsequent panel contouring according to elasticity requirements, was found necessary for reasonably uniform planwise stress-distribution across inserts up to 20 in. span, the maximum size so far employed.

* A proprietary asbestos-reinforced P.F. plastic.

The real significance of this principle of stress pattern interplotting however, lies in its general application to structural design.

Theoretical analysis of load diffusion both in the plane of a panel and through its thickness is considered in detail at para. 6 of this report.

The experimental investigations are considered in order of increasing load capacity.

2 Initial experiments

Early experiments were small in scale but the results were of value because

- (a) nothing was previously known about the load capacities of inserts of any given size or shape
- (b) they demonstrated that with satisfactory glue adhesion to the metal, the most consistent type of failure was shear in the plastic material, well outside the glueline, often within the first laminate
- (c) they proved conclusively that, as theoretically anticipated, the relative elastic moduli of steel and plastic greatly influence optimum insert dimensions and insertion depths for most efficient stress distribution in both materials and in glue layers.

For these exploratory experiments conditions were necessarily somewhat arbitrary; constructional details, however, are given below, since with modification and refinements of technique they formed the basis of the larger scale work.

2.1 Glued inserts in simple test panels

Convenient test pieces took the form of plain rectangular laminated Durestos panels with two exactly similar opposed inserts, each terminating in a projecting lug suitable for attachment to testing machine shackles by means of simple pin joints.

2.11 Inserts

Inserts were cut by bandsaw from nominal 10-SWG spring steel sheet, Spec. D.T.D.138A of the order 4.0 tons/sq.in. U.T.S., as received, without heat treatment. With the exception of the first spike-shaped inserts, corners or abrupt changes of shape were suitably radiused, and the perimeters of areas to be glued chamfered to form a continuous feather-edge, except round the lugs.

Surfaces for gluing were cleaned first with coarse, then with finer emery cloth to remove scale, the strokes being always in the same direction in order to facilitate final cleaning.

The bright steel surfaces were degreased with pure benzene by vigorous application to and fro along the emery scratches with successive wads of clean crumpled tissue paper soaked in the solvent. This process was repeated until the paper remained clean. A final rinse in benzene completed the degreasing which was done shortly before use, care being taken to avoid subsequent contamination, e.g. by fingermarks, before gluing.

2.12 Test panel construction and assembly

Panels were built up of an even number of 0.06 in. Durestos felts to a finished thickness such that failure would be more likely at an insert than elsewhere. Panel size was decided on a rough estimate of insert tip separation such that when the test-piece was eventually loaded, each insert could be considered as acting more or less independently.

It was realised that these simple test-pieces were not good load diffusers; gradation of panel thickness for improved stress distribution followed later from elastic considerations.

The felts were stacked in two equal piles with the longer edges adjacent, glue being applied (2.13 below) to the topmost face only of each pile, over areas at each end of the same shape as the inserts, but extending an inch or so all round; there were four such areas in all. Glue was also applied to both faces of the two inserts, cleaned as already described. The inserts were placed one at each end of one of the felt piles and carefully aligned in precise opposition. The top (glued) felt from the other pile was inverted and placed directly upon the inserts without disturbing their alignment. The rest of the felts were assembled in order so that all were in register.

The result was a rectangular 'panel' with the two insert lugs projecting from the ends.

2.13 Gluing

A hot-setting glue giving good bond strength to steel and with much the same cure cycle as Durestos was available, (Bakelite J.11185) and was found satisfactory. A few experiments were later made with another glue, but the above material, which combines thermo-setting and thermoplastic components in a single viscous syrup, has not been bettered for gluing the steel inserts into Durestos.

The syrupy glue was diluted with about 30% methylated spirit before use, to facilitate spreading.

Since Durestos is porous in texture, glue starvation at the joint was obviated by prior application to the felt areas to be glued (not steel) of two brushed coats of 7% Formvar in a 70% benzene-30% alcohol solution; the second coat was applied an hour or so after the first. This thin thermoplastic film tends to restrict glue to the actual joint faces during early stages of cure when glue viscosity is at its minimum.

However, at a later stage it was found that the high thermoplastic content of J.11185 (in the form of polyvinyl butyral) was sufficient to render unnecessary separate sealing coats. This is considered at 3.2.

2.14 Vacuum moulding

The panels, made up as described at 2.12 above, were provided with thermocouples for progressing of the cure cycle. These were situated

- (a) at insert positions in contact with the steel, centrally through panel thickness
- (b) at centres of longer sides, also at mid-thickness
- (c) on the mould face beneath the panel and on top surfaces.

The projecting lugs were raised from the mould face by small piles of felts of half panel thickness less half steel thickness to provide support, otherwise they would be tilted downwards by bag pressure. Cellophane was interposed between these felt packs and the lugs to obviate sticking.

The panels were then vacuum-moulded in the usual manner² in the R.A.E. moulding rig, the cure temperature of 150°C being reached in $1\frac{1}{2}$ - 2 hours and maintained for a further $1\frac{1}{4}$ - $1\frac{1}{2}$ hours. The vacuum of 25-27 in. of mercury was maintained until final cooling to room temperature.

2.15 Mechanical testing

Tension tests were conveniently made in an electrically driven 10 ton Olsen machine, the rate of load application being about 2 - 3 tons per minute. A few sharp cracks were heard from time to time, ascribable to glue flash fractures. These were more severe where the glue had exuded round the necks of lugs. After failure of the specimens, which was sudden, the testing machine was speeded up to effect complete withdrawal of the failed insert from the panel for examination.

Panel compression tests (insert shear reversed in direction) were deferred until stabilisation could be accomplished, with end fixation of the lugs instead of the simple pin joints. (For Rates of loading, see Appendix I).

2.2 Relative efficiencies of insert shapes

A series of experiments with differently shaped inserts provided useful data, summarised in Table I and discussed below.

2.21 Tapering to narrow point in both planes

Consideration of scarf joints first suggested a long tapering sword-like insert, or a combination of several inserts, disposed fanwise for diffusion of loads into panels or shells. Hence two such prongs 12 in. long and 1 in. wide at the neck of the lug were moulded into a 36 in. x 6 in. panel as described at 2.1.

A tension load of 3.8 tons caused failure of one insert in shear, the mean shear stress being 710 p.s.i. The appearance of the insert after complete withdrawal was interesting (extreme left, Fig. 1). The glue/steel bond was intact over the glued area except at the extreme tip. The Durestos had failed in shear about half way through the lamination adjacent to the insert, a distance of 0.015 in. away from the glue line. There was no evidence of delamination of the plastic over the insert region. For a distance of $2\frac{1}{4}$ in. from the point, the spike was almost bare; a trace of glue remained but no Durestos.

Hence this rudimentary form of scarf joint in two planes was very inefficient because of the uneven stress distribution over the glued area. This latter was very small at the pointed tip and the peak shear stress excessively high.

This throws an interesting light on the behaviour of high stiffness fibres surrounded by much lower stiffness resin existing in these fibre-reinforced materials, the fibres being analagous to sword-type inserts on a very small scale.

2.22 Parallel flat strips

Parallel steel strips with semi-circular ends, chamfered around the edges as before, were glued into 24 in. x 6 in. Durestos panels and vacuum

moulded. To maintain the same glued area for comparison with the above spikes, the depth of insertion was 6 in. instead of 12 in.

The failing load for the first panel was again 3.8 tons, the same as for the spike-type inserts. The failed strip was completely covered with Durestos, showing the woolly appearance of severed asbestos fibres. (Fig. 1, second from left, top row).

Repeat tests gave slightly higher loads but all were of the same order of about 4 tons (Table I). In one or two, gluing was imperfect; one insert in particular, though failing at the higher load of 4.32 tons, was imperfectly stuck except for the last 2 inches of the tip (Fig. 2A, right) whereas a precisely similar specimen from another such panel, failing at 4.15 tons, showed uniform shear failure in the Durestos, with perfect glue/steel adhesion.

Since the elastic moduli of steel and Durestos lengthwise are respectively 30×10^6 p.s.i. and 2.1×10^6 p.s.i. it was concluded that the load was carried chiefly by the tip areas of inserts, the steel (of the thickness used for these experiments, 0.112 in.) being too stiff to strain with the Durestos sufficiently to carry load further back along the after-portion.

A further experiment confirmed this. Two more panels were constructed with exactly similar inserts. The first pair were glued over a distance of 4 in. from their tips; the second pair 2 in. only from the tips. Corresponding areas of inner felt faces next to the steel were also glued. As a precaution against Durestos-resin adhesion to unglued steel, a layer of cellophane was wrapped round the bare parts. The inserts were assembled and the panels vacuum-moulded simultaneously.

Failing loads were 3.9 and 3.79 tons respectively, compared with 3.8 tons for the first insert of this type, glued the full 6 in. of its length. Fig. 2B shows the three inserts side by side.

Mean shear stresses per sq.in. total glued area were respectively 710 p.s.i. for 6 in. effective insertion depth, 1120 p.s.i. for 4 in. and 2250 p.s.i. for 2 in. In the previous test where poor adhesion had extended to within 2 in. of the tip, though glued the full 6 in. (Fig. 2A, right), sufficient well-stuck area remained to sustain 4.32 tons before failure, showing good agreement with the above test where the glue had purposely been applied over 2 in. only at the tip.

However, parallel strip inserts showed only slight improvement on tapered spikes of twice the length and having the same glued area; high peak tip stresses still occurred with little or no stress in the aftermost two-thirds of the length.

It therefore seemed reasonable to reduce the depth of insertion, consistent of course with the provision of sufficient area for shear attachment of the two materials by means of the joint.

2.23 Fishtail: increased span, reduced insertion depth

Since increase of span distributes the load over a longer edge, and glued area is most efficiently disposed when near tips for relatively thick inserts, the shape was modified in stages to that of a triangle suitably radiused to blend in with the circular lug. Sharp corners at the base were rounded since they would otherwise be stress-raisers. The true span of inserts was thus rather less than the bases of the triangles from which they were developed.

With insert span increase, later panels were suitably widened to increase the amount of diffusion in approximately the same proportion.

Fig. 1 illustrates various shapes which were tested and their appearance after failure. (For clarity, the edges of inserts were lightly chalked; dotted lines represent parts still buried in the panel remnant). Failing loads, shear and tensile stresses are shown against scale drawings of inserts, in Table I. Glued areas were measured by planimeter where possible i.e. after a clean shear failure. This was partly to check if the tapered inserts had suffered outward displacement during moulding, before solidification of the glue. A jig was used later to prevent movement.

It was intended to keep the glued area constant at 10 sq.in., but the more efficient the insert the nearer the load approached that of lug failure by elongation. Hence for the last three tests (Table I) the area was reduced to 8 sq.in.

In all these failures the glue/steel and glue/Durestos bonds remained intact over the whole adhesion area, shear failure being in the Durestos itself up to 4.9 tons. Above this, tension failures occurred at tip regions where stress was most concentrated, See Fig. 1.

Table I shows that with the exception of the reversed triangular insert, a broad "spike", mean shear stresses have risen steadily with progressive span increase and insertion decrease within the range of shapes tested.

The 4 in. span by 1.25 in. deep fishtail was considered an optimum for this steel thickness; further span increase and corresponding depth reduction would result in excessive bending flexure causing load relief at the tips, thus upsetting crosswise stress distribution.

The final test in this series was made with heat-treated inserts (80 tons/sq.in. U.T.S.) and a 12 instead of an 8-felt panel to reduce the likelihood of tension failure occurring in the Durestos at insert tips before the maximum shear strength of the joint had been attained.

The failing load was 8.2 tons, giving a mean shear stress of 2300 p.s.i. over the glued area.

Steel stiffness of course, was still excessive, and it was then realised that the ideal steel section would be similar to that of a hollow-ground razor (Fig. 22) an extremely difficult shape to produce without distortion.

Thin sections of high strength steel were eventually used for larger inserts (4.1 and Fig. 23), but for the present, comparative tests were continued with the simple 4-inch span type cut from sheet and thinned at the tips. The panel size was maintained at $14\frac{1}{2}$ in. by 8 in. the separation: span ratio being 3:1. Further experiments were made on panel thickness and on reproducibility of failing loads of these simple inserts.









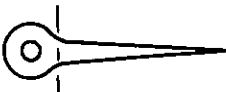

2.3 Effect of panel thickness on insert failure

Table II shows test results for panels of 8, 12 and 16 felts respectively, the first three being taken from Table I for direct comparison.

Of the four failures with 12-felt panels, one only, at 8.52 tons, occurred in clean shear in the Durestos; that at 8.2 tons in part-shear,

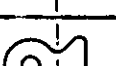
Glued inserts: span increase insertion decrease

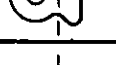
TABLE I

Shape of insert	Area sq.in.	Span in.	Depth of insertion in.	Tip sepn. in.	Panel size in.	Failing load tons	Mean shear stress p.s.i.	Mean tensile panel centre	Type & position of failure
	12	1	12	12	36x6	3.81	710	5940	Shear in Durestos glue strip of tip 2"
	12	1	6	12	24x6	4.15	773	6450	Shear in Durestos
	"	"	"	"	"	3.80	710	5920	" " "
	"	"	"	"	"	3.99	745	6200	" & pt glue strip
	"	"	"	"	"	4.31	805	6720	" " " " "
	7.785	"	4 glued	"	"	3.90	1120	6070	" " " " "
	3.785	"	2 glued	"	"	3.79	2250	5370	" in Durestos
	10	1.5	4	16	24x6	4.55	1020	7070	Shear in Durestos
	12.56	2	4	16	24x6	5.05	893	7850	Shear in Durestos
	10.6	2	3.5	17	24x6	4.90	1032	7620	Shear in Durestos
	10.5	3	2.5	19	24x6	5.83	1242	9060	Tension in Durestos over tip
	10.4	3.5	2	20	24x6	5.79	1247	9000	Tension in Durestos
	10.45	4	1.67	20.6	24x8	6.19	1328	9630	Tension in Durestos
	8	4	1.25	21.5	24x6	6.17	1730	7200	Tension in Durestos
	8	4.5	1.25	21.5	24x8	5.69	1590	6640	$\frac{1}{2}$ tension and $\frac{1}{2}$ shear in Durestos
	8	4	1.25	12	14.5x8	8.20	2300	6360	$\frac{1}{2}$ tension and $\frac{1}{2}$ shear in Durestos *

Common conditions

Steel

DTD 138A not hardened. Thickness 0.112" . Angle at nose 12°

Durestos

Curing time 1½ - 1½ hr at 150°C Vacuum 25"

Felt laminates 8

Gluing

2 coats Formvar on felts.

Glue Bakelite J.11185

* Hardened and tempered steel. Felt laminates 12.

TABLE II

Panel thickness: effect on failing load

A. Glue: J.11185, with or without formvar felt treatment

No. of felts	Cure 150-160°C hours	Failing load tons	Mean shear stress p.s.i.	Mean tensile stress at tips p.s.i.	Mean tensile stress panel centre p.s.i.	Description of failure (Glue adhesion satisfactory)
8	1.25	6.19	1328	14,450	9630) Tension in Durestos: /* } Fracture across insert tip //*
	1.25	6.17	1730	14,350	7200	
12	1.5	8.2	2300	12,700	6360	Durestos shear one side, tension other Clean shear Durestos Tension in Durestos across tip Tension in Durestos across tip
	1.25	8.52	2380	13,250	6630	
	1.0	7.62	2135	11,840	5900	
	1.0	8.02	2240	12,500	6400	
16	1.0	>7.58	2120	8840	4420	Steel lug failure (insert not H.T.)* Shear in Durestos Shear in Durestos Durestos shear 1 side, tension other Shear in Durestos " (D.T.D. 331 steel)** Shear in Durestos
	1.25	7.85	2200	9160	4700	
	1.25	7.55	2115	8800	4540	
	3.0	9.12	2550	10,600	5280	
	3.75	8.4	2350	9800	4775	
	3.75	6.8	1900	7940	3970	
	3.75	6.9	1930	8040	4020	
	3.75	7.27	2035	8470	4240	
		7.54	2110	8800	4400	
	2.75	7.75	2170	9020	4525	
	2.75	6.9	1930	8040	4020	
	2.75	7.2	2010	8400	4200	
	2.75	7.2	2010	8400	4200	
	2.75	7.27	2035	8470	4240	
	2.75	7.21	2150	8410	4205	
		2.75	7.75	2170	9020	
	3.75	9.3	2600	10,850 _C	5425 _C	Panel in compression Shear in Durestos (Plate IV)

B. Glue: Bakelite R.540 with Formvar treatment

16	1	7.26	2030	8450	4225) Shear one side, tension other, with auxiliary fracture round insert } Shear in Durestos
	1.25	7.65	2140	8920	4580	
	3	8.1	2270	9450	4830	

Common conditions Steel D.T.D.138A (Heat treated except where marked*)
 Thickness 0.112 in. Angle at nose 12° approx.
 Span 4 in. Area 8 sq.in. Insertion 1.25 in.
 Tip separation 12 in.
Durestos Panel 14.5 in. x 8 in.
 Cure temp. 150° - 160°C
 Thickness one cured laminate 0.03 in.

** Area 7.5 sq.in. Insertion 1 in.
 / Panel size 24 x 8 in.
 // Panel size 24 in. x 6 in.

part-tension (Fig. 3A); the remaining two failed in tension across an insert tip (Fig. 3B).

To prevent such tension failures complicating future tests 16-felt panels were used, there being no point in continuing with insufficient material at insert tips where peak stresses were highest. As the table shows, subsequent failures were nearly all in clean shear, an exception being that at 9.12 tons (Fig. 3C), where, at this higher than average load, the likely sequence was primary shear failure of one side immediately followed by bending stress added to the tension in the other.

A series of the 16-felt panels was made; they were vacuum-moulded in batches of up to six at a time (the limit of the available equipment), so that panels from the same batch were strictly comparable. However, other variables were being explored at the same time, and these are given in the Table, whence it is seen that wide variations in curing times appear to have little influence on the results.

These variations were made purposely in order to ascertain if, in felt assemblies of greatly unequal section such as are often necessary in large structures, the thinner sections would suffer much loss of strength from over-curing. This is of course assuming uniform heat dissipation per sq.ft. of mould and blanket (see, however, end of 4.3).

Although an optimum period for curing Durestos has been recommended² it must be remembered that 'hot spots' often limit the permissible rate of heating of large mouldings; thus sufficient time must be allowed for every part to attain and then maintain the cure temperature.

From Table II, the arithmetical mean failing loads are as follows:-

<u>Thickness</u> <u>(No. of felts each 0.03 in. cured)</u>	<u>Failing load</u> <u>tons</u>
8	6.18 (mean of 2)
12	8.09 (mean of 4)
16	7.54 (mean of 19)

Though the results for 12-felt panels are slightly up, it can be inferred that within the scatter range, above a certain minimum necessary to carry tension, mere increase of panel thickness has negligible effect on load capacity. It has, however, a large effect on diffusion (See 6.2).

These results ignore the obviously stronger inserts which remained intact. The difficulty of making satisfactory attachments to "failed ends" of panels for withdrawal of the opposite insert made it hardly worth while, though for certain high-temperature tests (3.2) this was done, with partial success only. (See end of 5.2).

Variation

For true statistical significance the number of exactly comparable tests of this kind should be about 60, instead of the 16 in Table II.

However, the standard deviation for insert failing loads is 0.57 ton on the mean value of 7.52 tons.

The coefficient of variation is thus 7.64%, exactly comparable with the known variation of Durestos (6% - 8%). This is reasonable, since

failure occurs in Durestos preferentially, and better than expected considering the many variables, including stress concentrations in insert regions.

One compression result only appears in Table II. This test was merely a check to see if there was any reduction in failing load compared with tension, since the strength of Durestos along the 60% fibre-orientation axis in compression is only two-thirds of that in tension (See however 5.2).

The result, for the externally-stabilised panel with end fixation, mounted between spherically seated anvils in a 30 ton Avery testing machine, was greater than the best for tension in this group, failure occurring by shear at one insert. The panel was cut around this area; the portion so obtained separated easily into two halves for examination of the failure (Fig. 4).

3 Four-inch span fishtail inserts in plain Durestos panels under various conditions

Having determined some of the load characteristics of simple relatively small inserts, it was desirable, before scaling-up, to investigate conditions (e.g., glue change, temperature, deterioration, etc.,) likely to influence insert failing loads.

3.1 Comparative glue tests at normal temperature

Though Bakelite J.11185 had so far proved quite satisfactory for gluing of inserts into Durestos, its high thermoplastic content might be expected to reduce joint strength at elevated temperature.

The first step was to ascertain if a good enough bond to steel was obtainable with a reduced proportion of thermoplastic. A systematic testing of many glue mixtures with graded thermoplastic contents was outside the scope of this work, since it has been shown (2.23) that under normal conditions the glue bond is stronger in shear than Durestos.

However, the results of a few tests using both J.11185 and Bakelite R.540 (a P.F. resin without or with very little thermoplastic, and hence similar to Durestos resin), with and without Formvar sealing coats, which provide a ready means of varying the amount of thermoplastic in the joint, are given in Table III, and summarized in Table IV.

3.11 Effect on insert failing loads of wetting prior to vacuum moulding

In good moulding condition, Durestos is flexible and easily manipulated. Consolidation of built-up laminates is then satisfactory, with little "stepping". Loss of moisture through exposure to a dry atmosphere in transit, storage, or during use causes the sheets to stiffen so that not only are they liable to crack if bent, but final bond strength between felts is impaired.

Restoration of moisture may be accomplished either in the liquid or vapour phase, the former by direct application, the latter by storing for 2 - 3 days before use in an atmosphere with a controlled high relative humidity, preferably 93%, though not critical between 75% and 100%. Such conditioning over saturated sodium sulphate solution at about 20°C was the method normally used for panel felts.

TABLE III
Glue comparison

Glue	Sealing coat applied to felts	Treatment of felts before cure	Failing load tons	Mean shear stress p.s.i.	Mean tensile at tip p.s.i.	Mean tensile panel centre	Type of failure
J.11185	2 coats 7% Form-var	Wetted	8.2	2300	12,780	6360	Combination shear/tension*
			8.52	2380	13,250	6630	Clean shear Durestos*
			7.85	2200	9160	4700	Clean shear Durestos
			5.31	1485	8250	4140	" "
	None	(Pre-pressed (750 p.s.i.	7.62	2135	11,840	5900	Tension across tip*
			>7.58	2120	8840	4420	Lug failure (one lug not HT)
			7.55	2115	8800	4400	Shear in Durestos
			9.12	2550	10,600	5280	Durestos shear one side, tension other
			9.5	2660	11,100	5550	Durestos shear one side, tension other
			8.4	2350	9800	4775	Shear in Durestos
			6.8	1900	7940	3970	" " "
			6.9	1930	8040	4020	" " "
			7.54	2110	8800	4400	" " "
			7.75	2170	9020	4525	" " "
			7.75	2170	9020	4525	" " "
			6.9	1930	8040	4020	" " "
			7.2	2010	8400	4200	" " "
			7.2	2010	8400	4200	" " "
			7.27	2035	8470	4240	" " "
			7.21	2150	8410	4205	" " " **
Bak. R.540	2 coats 7% Form-var	Wetted	8.02	2240	12,500	6250	Tension Durestos (tip)*
			7.26	2030	8450	4220	Durestos shear one side, tension other.
			7.65	2440	8920	4580	Durestos shear
			8.1	2270	9450	4830	Durestos shear
	None	Wetted	5.24	1468	8150	4070	50% stick only*
			5.88	1650	6880	3440	Less than 50% stick
No glue except Durestos resin	None	Wetted	4.81	1347	7480	3740	Shear in Durestos
			2.59	750	4025	2020	Under 50% stick*
			2.02	566	2360	1180	Very little stick
			4.46	1248	7150	3460	Shear in Durestos*

Common Conditions:- Steel D.T.D. 138A Heat treated. Thickness 0.112 in.
Span 4 in. Area 8 sq.in. Tip separation 12 in.
Angle at nose 12° approx.
Durestos Panel size 14.5 in. by 8 in.
No. of felts 16 (except where indicated)

* 12 felt panels

** 7.5 sq.in. area, insertion depth 1 in.

TABLE IV

Average failing loads in tons of glued inserts with and without sealing coats

Glue	With Formvar sealing coats as at 2.13	Glue alone as supplied
J.11185	8.19	7.52
R.540	7.78	5.56

Thus, for tests at room-temperature, sealing coats showed an advantage with both types of glue. (See, however, Table VI).

3.11 (Contd)

Addition of moisture by spraying or sponging is difficult to control. A few experiments with panels built up in the usual manner except that of moisture addition by sponge application hardly sufficient to darken the Durestos appreciably, revealed that during subsequent moulding, loss of resin by absorption into ventilating layers considerably upset the joint as shewn in Table III. Table V shows this more clearly:

TABLE V

Effect of wetting before cure

Glue and felt treatment	Insert failing load tons (Av. of Table III)	
	Felts in satisfactory mouldable state	Very dry felts moistened before cure by light sponging
J.11185 with sealing coats	8.19	5.31
J.11185 alone	7.52	-
R.540 with Formvar	7.78	-
R.540 alone	5.56	4.81
No glue (Durestos resin only)	2.3	4.46

The bottom figures refer to Durestos/steel only, showing poor adhesion unless the steel is wetted (actually with an aqueous solution of Durestos resin acting as glue. Though adhesion to the steel was sufficient nearly to double the failing load, the shear strength of Durestos had suffered through resin starvation, particularly at outer laminate faces. Hence if, for intricate mouldings, water in the liquid state has to be used, glue should also be added to compensate for loss of felt resin into absorbent material during vacuum moulding. The optimum resin content for Durestos is about 55%.

3.12 Effect of pre-pressing on strength

A 16-felt test panel with inserts glued with plain J.11185 glue was pressed between parallel platens at 750 p.s.i. for 5 minutes at room temperature before vacuum moulding.

The subsequent test failure (Fig. 3D) occurred at 9.5 tons compared with the average 7.52 tons, a significant difference.

The following points may be noted:

- (i) Over the steel, except at the nose, the consolidating pressure exceeded 750 p.s.i.
- (ii) Glue, of high viscosity because of solvent loss during open assembly, was pressed into the felts rather than expressed from them, reducing voids near the glueline.
- (iii) The effect of concentrating the asbestos fibres closer to the steel is advantageous in that it increases Durestos shear stiffness locally, so that more load is transferred through the joint to the thicker steel section away from the nose, relieving the high tip peak stress of these thick inserts.

Pre-pressing is advantageous and where practicable, is recommended.

The above points may have a bearing on high strength inserts in high pressure mouldings, provided ventilation problems can be overcome.

It is foreseen that for large low-pressure mouldings a local high pressure over inserts might be achieved by incorporating in the insert locating jig (see 8.2), a mechanically-operated platen suitably shaped to apply extra pressure over these areas.

A warning is needed, however, that for the plastic, the coefficients of thermal expansion vary with moulding pressure. Some evidence of warping in large wing mouldings has been attributed to residual stresses on cooling.

3.2 Effect of temperature on load capacity

At higher than normal temperatures a fall in insert strength was expected for two reasons:-

- (i) The ultimate tensile strength of vacuum-moulded Durestos was found⁴ to fall steadily from about 23,000 p.s.i. at room-temperature to 16,000 p.s.i. at 120°C. No values are available for shear but the drop should be proportional.
- (ii) Presence of thermoplastic in the glue.

A number of 14½ in. by 8 in. 16-felt test panels with opposed inserts was made up for preliminary tests at 90°C, this temperature being chosen because

- (a) of normal aircraft design requirements
- (b) it approximates to the average softening temperatures of thermoplastics used as ingredients in these types of glues.

The panels were from the same batch, vacuum-moulded simultaneously.

Three types of glue application were employed; J.11185 with and without Formvar sealing coats, and R.540 with Formvar, since the bond to steel is unsatisfactory without it (3.1; Table IV).

For tests at 90°C in the horizontal position (10 ton Olsen machine) the panels were completely surrounded by an electrically heated muff (flexible wire elements sewn into glasscloth), power being supplied through a Variac transformer.

During construction, the panels were provided with thermocouples moulded in at the glue line adjacent to the steel at each end, so that the temperatures of both inserts could be measured. Heating was adjusted so that they were equal.

About half an hour's 'soaking' was given to ensure that each insert and surrounding material had reached the same steady temperature before commencement of test.

Results are shown in Table VI.

TABLE VI

Effect of glue variation on failing loads at 90°C			
Gluing	Insert failing load, tons		Type of failure
	20°C	90°C	
J.11185	8.33	7.22	All shear in Durestos with good adhesion to steel
J.11185 & Formvar	8.19	6.95	
R.540 & Formvar	7.78	5.99	

Although the quantities of Formvar and glue are small compared with total Durestos resin, the drop in load capacity is perceptible with Formvar present at the joint.

Taking these results merely as a pointer, it seemed best to omit Formvar in future, and use J.11185 only.

No glue starvation effects had been noticed with this material, probably because its own high polyvinyl butyral content is sufficient for "sealing".

A wider temperature range, from 20°C to 145°C was now explored for simple J.11185 glued joints in another batch of panels. The test method was exactly the same, using the heated muff.

To find the effect of repeated heating, the stronger inserts were re-tested at the same respective temperatures. Failed ends of panels were sawn off square and drilled for bolts, which passed through two steel plates, one each side, the assembly being in fact a large bolted joint fitted with a lug.

The results of both series of tests are shown in Table VII, a few of the previous results for 90°C. being incorporated.

TABLE VII
Effect of temperature on insert load capacity

Degrees centigrade	First heating				Second heating (Test of remaining insert)			
	Failing load tons	Mean shear stress p.s.i.	Mean tensile stress at tip	Type of failure	Failing load tons	Mean shear stress p.s.i.	Mean tensile stress at tip p.s.i.	Type of failure
20	8.33	2330	9720	Shear in Durestos	-	-	-	
70	7.97	2230	9280	" " "	>8.15	2280	9510	Failed panel (bolt holes)
80	7.73	2160	9000	" " "	>7.2	2010	8400	Failed panel (bolt holes)
90	7.22*	2080	8430	" " "	-	-	-	
100	6.1	1710	7120	" " "	4.9	1372	5720	Shear in Durestos
115	6.39	1790	7460	" " "	5.64	1570	6580	" " "
130	5.15	1442	6000	" " "	5.4	1510	6360	" " "
145	6.1	1710	7120	" " "	4.8	1342	5600	" " "

Common conditions: Steel - D.T.D. 138A Heat treated. Thickness 0.112 in.
Nose angle 12° approx. Span 4 in.
Area 8 sq.in. Insertion 1.25 in.
Tip separation 12 in.
Durestos - Panel 14.5 in. x 8 in. 16 felts
Glue J.11185
Cure 2 - 3 hours at 150°C

* Mean of 2 results

Conclusions

First heating: From 20 to 90°C the drop in strength was not serious, but between 100° and 145°C it was more pronounced.

Second heating: Since these inserts had not failed in the first tests, the effect of re-heating on their strengths was more adverse, though there was little falling-off up to 80°C. The exact figures for the first two were not obtained because of premature panel failure at bolt holes at the higher loads, illustrating the superiority of glued inserts over this type of bolted joint.

The general conclusion is that temperature characteristics of such joints are largely those of Durestos, provided that the properties of the glue do not fall off more rapidly than those of Durestos itself.

These tests suggested that provided maximum loads are not sustained at temperatures greater than 80 - 90°C glued inserts should be satisfactory. Repeated loadings at higher temperatures should be avoided. There has been no opportunity for hot creep tests yet, but they are obviously necessary.

Low temperatures

The ultimate tensile and compressive strengths of Durestos have been measured⁴ down to -150°C where they approach each other at approximately 24,000 p.s.i.

Hence at low temperatures an insert glued into Durestos would be expected to carry greater load were it not for increase of brittleness.

A check test was made with one of the 16-felt panels with opposed inserts having an average failing load at room temperature of 7.52 tons. Using a box packed with solid carbon dioxide and allowing time for a steady temperature of -80°C to be attained, the failing load was 8.0 tons.

The main reason for this check test was to find if differential strain due to different coefficients of expansion, which would be expected to have an adverse effect (see 7.5), did in fact reduce failing load, the effective temperature range here being from +150°C (cure temp.) to -80°C (test temp.) i.e. 230°C.

The result indicated the probability that within this temperature range Durestos strength increases more than is required to offset the effect of differential strain.

3.3 Deterioration

Short term tests of the effect of moisture on failing loads were required.

3.31 Water immersion

Two exactly similar panels with inserts were completely immersed in plain tap water in a deep tray for 21 days, and pulled while still wet, at room temperature.

The failing loads were 5.71 and 6.2 tons, the average adverse effect being 21%.

3.32 Climatic exposure

Three similar panels, vacuum moulded in one batch, were exposed with unprotected lugs, for 5 months on the open roof under winter conditions before tension testing.

TABLE VIII

Deterioration

Panel conditions before test	Failing load tons	Mean shear stress p.s.i.	Mean tensile stress at tip p.s.i.	Mean tensile stress panel centre p.s.i.	Type of failure
Pulled damp as taken from exposure site (5 months winter roof exposure)	6.51	1825	7600	3800	Clean shear in Durestos
48 hours drying out in laboratory	6.0	1680	7000	3500	Shear in Durestos
Panel dried at 110°C in vacuo (27" Hg) for two hours. Pulled at room temp.	7.07	1980	8250	4125	Shear in Durestos
Panels soaked in water for 21 days	5.71	1600	6680	3340	Durestos shear
	6.2	1737	7240	3620	Durestos shear
Average value for these inserts in similar panels not exposed or wetted	7.52	2110	8800	4400	Mostly shear; a few part tension, part shear

Common conditions: Steel As in Table VII

Durestos 16 felt panels 14.5 x 8 in.

Glue J.11185 No formvar

Cure time 2 $\frac{3}{4}$ hrs at 150°C

Table VIII shows the effect on insert strength.

The first, pulled at once while still damp, failed at 6.51 tons instead of the average 7.52 tons for such panels in the dry state. The strength reduction was thus 13.4%.

The second panel, kept for 48 hours in the laboratory for superficial drying-out gave a lower load of 6.0 tons, a drop of 20%.

After thorough drying at 110°C under vacuum for two hours and cooling to room temperature, the third panel failed at one insert at 7.07 tons, a reduction of only 5.9% on the average figure for these panels (7.52 tons).

Examination of failed inserts showed that though lugs had rusted there appeared to be little or no penetration of rust under the glue layer, which seemed unaffected, failure being by clean shear in Durestos away from the glue line as usual. Alternatively the glue resin may act as rust inhibitor for steel.

Hence the effect of such exposure was largely that of moisture on Durestos. Summer exposure tests have not been done, but outer Durestos would be expected to protect the joint from the effect of U.V. so that deterioration should be influenced chiefly by intermittent heating and cooling plus occasional wetting.

4 Inserts up to 20 inch span with panel contouring for diffusion of point loads up to 50 tons

Failing loads of the 4 in. by 1.25 in. fishtail inserts, of the order of 2 tons per inch of span (1 ton/sq.in. average shear stress over total glued area) were sufficiently promising for scaling up of insert dimensions, assuming linear proportionality between span and load, though not between area and load.

Increase of span was accomplished in two stages: first approximately twice, then five times, in an attempt to meet fully factored load requirements for front and rear root attachments respectively for the R.A.E. plastic Delta wing, (See 8.1 and Fig. 39).

Contouring is necessary to increase radial stress diffusion, and hence load capacity for minimum weight, and is most efficient when symmetrical about an insert. In practice this would involve external as well as internal contouring of the wing shell at the root, not permissible in a wing designed to a definite aerodynamic profile having single curvature only. Contouring had thus to be limited to the inner surface so that representative test panels were necessarily asymmetrical in section.

For efficiency investigations however (5.2) a few completely symmetrical panels were made, the weight economy being about 30% compared with the asymmetrical type.

Inserts also were asymmetrical in section, thus differing from those used in the small scale experiments already described, though still centrally disposed in laminates to share shear stress as equally as possible between each glued face.

4.1 Inserts from 7 in. to 9 in. span in contoured panels

The difference from the 4 inch size lay in increased thickness and an extended tail instead of the circular lug. Early 7 in. types were of 0.30" thick spring steel plate with tips thinned by grinding so that both faces tapered to a feather edge. Subsequent inserts were end-milled on one face only.

Though load capacity was in rough proportion to the 4 inch size, steel thickness and nose angle were excessive. This led to poor consolidation of Durestos at the tips because the bag tension reduced pressure over the resulting 'hollow'. Greater tip pressure was attained by introducing a roll of glass cloth beneath the top blanket and lying crosswise, so that bag tension assisted consolidation. This was, however, overdone, the Durestos being displaced and tip stress distribution upset, resulting in early failure at 8 tons.

Table IX shows variations of insert shape for these experiments, including the recessing of one pair to 0.06 in. over the adhesion area instead of taper milling, but the tip thickness was excessive.

Increase of span to 9.25 in. showed some improvement (highest 15.75 tons). A pair of inserts made with fishtail extended to give increased adhesion area, and milled further back, which reduced the nose-angle from 10° to 6° gave a satisfactory failing load (after a preliminary test showing poor consolidation) of 22.25 tons, with clean Durestos shear over both faces.

These inserts were recovered and used again in another exactly similar contoured panel, the failure this time being at 22.15 tons, showing good repeatability.

A rectangular tapered plate of almost the same span, $\frac{1}{2}^{\circ}$ less nose angle and 35% greater area gave a lower failing load of 19.1 tons with an abnormally low mean shear stress of 714 p.s.i. much of the thicker steel being redundant. Hence by trial and error a rough optimum had been found for insert dimensions. (Later, the design of correct shapes and sections for inserts became possible from theoretical analysis - see 6, and Figs. 21-23).

A compression test panel was made up with the pair of fishtail inserts giving the best tensile figures (above), the thickness being increased at the centre, compensating for the lower compressive strength of Durestos as compared with its tensile strength. The panel was stabilised by a wooden frame (the inserts being suitably fixed), and tested in compression (30 ton Avery machine), the failing load being 22.5 tons (Table IX).

The failed insert and the surrounding plastic are shown in Fig. 5; Fig. 6 shows the other face of this insert. The mean shear stress for the best fishtail inserts was, however, only half that produced by the 4 inch span type, apparently because of the scale effect well known with practical glued joints, load not being simply related to insertion depth.

These experiments were intended as a prelude to more efficient insert design for this size, but, in view of larger load requirements, improvements conforming with elastic theory which was being worked out at the time were incorporated in the design of inserts of 20 inch span. These were similar in plan form to that shown in Figs. 5 and 6, but were of thinner section over the adhesion area, with a nose angle of 1° only, and were profile-shaped before heat-treatment as shown in Fig. 7.

4.2 Contouring with stress-pattern interplotting for improved stress distribution

In the simple asymmetrically-contoured panels developed for the 7 in. and 9 in. inserts, where tip separation was large relative to panel width (Table IX), it is probable that the arbitrary panel contours used gave a reasonably uniform panel stress and load across insert span.

In the larger scale experiments, moulding equipment dimensions limited the panel size to 56 in. x 27 in. so that with 20 inch span inserts only 33 in. tip separation was possible.

For tests to be at all representative of stress distribution with diffusion around a single insert in a plastic structure, it was necessary for opposed inserts to take into account interaction between the two stress fields. This was accomplished by interplotting graphically according to the principles described at 6.17, the resulting contour shapes being seen in Fig. 9. This modified contouring gave much closer approximation to uniform planwise stress distribution across these large inserts. Improved diffusion by radial orientation of laminates, discussed at 7.3, was not done for test panels, but was incorporated in the plastic wing skin design at insert regions according to the best information then available.

The panels were constructed from felts cut to templates based on the interplots, and built up in the usual way as an assembly of laminates with the smallest contour outermost.

Those intended to simulate wing root end construction were asymmetrical in section as shown in Fig. 13, but panels completely symmetrical about each of the three principal axes were also made in order to test stress distribution theory. Fig. 18 shows one of this series.

4.3 Assembly and vacuum moulding of large insert test panels

Construction and assembly, following the same general procedure described at 2.1 are most easily explained by reference to photographs taken during the building of a typical asymmetrical panel with 20 in. glued inserts, it being most convenient to assemble in situ in the moulding chamber.

Fig. 8 shows the base felt pack with carefully aligned inserts assembled on the electrically-heated mould face after glue application to necessary areas and the required open-assembly for removal of excess volatile solvent. Durestos surfaces are glued over areas greater than those of inserts by 1 - 1½ in. all round, and the steel glued separately.

The first contoured felt shown standing on edge is lowered to cover insert adhesion areas and the rest of the laminates assembled in order (Fig. 9).

During assembly the necessary thermocouples were interleaved between laminates at points most suitable for temperature control during cure. Eight were generally used, four of which were in contact with the steel in the important tip regions. Then followed the usual assembly of venting layers, electrically-heated top-blanket, asbestos cloth and bag, and finally, the top frame with vacuum-seal.

When felts had stiffened by exposure to dry atmosphere during cutting and open assembly, gentle heat was applied with the assembled 'panel' in position so as to bring the average temperature up to 50 - 60°C maximum, this taking about half an hour. Durestos resin viscosity was thus lowered sufficiently to permit of better initial felt consolidation, with the added advantage of further removal of glue solvent not accomplished by mere open-assembly⁵; a few inches of vacuum only were maintained at this stage. Pre-consolidation was also applied to plastic wing insert felt packs. (8.2).

Cure proper then proceeded with application of full vacuum and rapid heating to 80 - 90°C and continued at the lower rate of about 30°C/hour until attainment of cure temperature, the time from starting

being about 4 hours for this stage. Heating was continued for a further 3 hours to ensure that every part of the assembly, though of varying section and complicated by the presence of large steel inserts, had attained the cure temperature of 150°C for the requisite period.

This long slow cure is advisable for all such composite thick assemblies; it also limits the temperature gradient over the range of maximum rate of evolution of volatiles from the resin curing reaction, so that they come off more steadily and diffuse more evenly through partly cured material.

This is true for thick Durestos assemblies generally, but much more important for the material beneath the inserts, particularly the glue. These precautions are considered in detail at 4.4 below.

Some practice in temperature control is required in order to hold the thin centres of panels at the permissible 150°C while the greater mass of material is coming up to cure temperature; this is a further reason for the slow rate of 30°C/hour. Temperature recorders are useful in this connection.

Cooling-off under vacuum to 50°C or less usually needed 2 - 2½ hours. The mould was then opened up and the panel provided with end fittings for mechanical testing. Pre-consolidation was found greatly to reduce 'stepping' at contours, thus improving smoothness of profile of the final surface. This was especially noticeable at root regions in wing moulding, where local heating around inserts, switched on in advance of the main mould, reduced overall moulding time to little more than that necessary for the other parts of the wing shell.

4.4 Ventilation of glued joints with metal inserts

The volatiles given off by a P.F. resin consist largely of steam which is an inhibitor and must be removed in order to obtain the best resin properties.

Good ventilation also enables heat from the exothermic poly- condensation to be dissipated as latent heat of vaporisation, thus reducing hot spots.

Vacuum moulding assists in this extraction of volatiles and at the same time produces a moulding pressure of nearly one atmosphere.

A vacuum gauge gives a misleading indication of the actual consolidation pressure as local restriction of volatiles causes steam pressure to build up. (Complete trapping would give about 80 lb sq.in. at 150°C, curing temperature).

It should be noted that for satisfactory removal of volatiles at very low pressure, extraction ducts should be of relatively large cross-section and pump displacement adequate.

The larger the metal insert the more it encourages local trapping of volatiles, the worst position being the centre of an insert under-surface. Thus the adhesion area with the longest diffusion-path is most affected, as shown in Fig. 10B. The resultant glue-bubbling, steel oxidation and lack of adhesion were worse the greater the quantity of glue and the higher the rate of temperature rise.

Top surfaces, however, were well-ventilated by the porous top glass cloth layers so that adhesion was satisfactory (Fig. 10A).

Venting layers alternately of glass cloth and copper gauze totalling $\frac{1}{2}$ in. thick under the whole panel and drilling of inserts brought about only slight improvement compared with glue reduction. The glue spread of 0.19 lb/sq.ft. which had been satisfactory with inserts even up to 9 in. span (Figs. 5 and 6) proved excessive for the larger inserts which compelled volatiles to traverse longer diffusion paths.

A much reduced glue spread, 0.05 lb/sq.ft, prevented bubbling and the joint gave the high failing load of 52 tons (Fig. 14) but some starvation was evident, hence this was the lower limit.

The most satisfactory glue-spread on steel and Durestos was 0.06 - 0.07 lb/sq.ft. of J.11185, diluted 50% W/W with methylated spirit, applied in 4 - 5 successive coats with a total open-assembly time of 2 hours.

A failed insert from a subsequent panel glued in this way had the appearance shown in Figs. 11A and B. Sanding of the Durestos down to the glue showed the glue layer to be uniform and well bonded to the steel over both faces.

4.5 Loading tests with inserts of 20 inch span

Tensile testing followed the usual procedure, but the size of the panels necessitated a large machine (200 ton Avery used over the 100 ton range). Panels were provided with suitable end-fittings and set up as shown in Fig. 12. The asymmetrical section of this panel, typical of the first group, and representative of plastic wing root construction, is shown in Fig. 13. The rate of loading for all tests was about 16 tons/min. (Appendix I).

The respective contoured and plane faces of the same panel after failure at 52 tons in the region of one insert are shown in Figs. 14 and 15. Intermittent sharp cracks, attributed to brittle glue "flash" fracture during straining, accompanied the earlier tests, but after modification of gluing technique for ventilation reasons, (4.4 above) this flash no longer existed; the tests being almost noiseless right up to failure. Compression panels even with glue flash present were always quiet up to failure.

Compression testing was less straightforward than tensile, since a tensile test piece is inherently stable, whereas for panel compression external stabilisation and end-fixation are necessary. It is also essential, if test results are to have real significance, that panels be accurately aligned between the spherically-seated anvils of the machine.

Satisfactory stabilisation was accomplished by two heavy timber frames very lightly clamped each side of the test specimen by means of tie-rods. The inner faces of the cross-pieces in contact with the panel surfaces were accurately scribed to them. Figs. 16 and 17 show the general arrangement, particularly the heavy fabricated end fixings.

Test results

In this larger-scale work, variables were explored to an extent such that few test panels were exactly similar, but where duplicates or triplicates were tested, both in tension and compression, there was good agreement after initial difficulties had been overcome.

Shear stresses at inserts due to tension loads are not exactly comparable with those due to compression of equal magnitude, nevertheless

the close agreement between tension and compression failing loads with 9 inch inserts in similar but smaller panels (4.1 above) was also found for the 20 inch size in the large panels (Table X, Nos. 6-9 inclusive). The lower compressive strength of Durestos compared with its tensile strength does not reduce load capacity because the failures are in shear (See 5.2).

Tension and compression results with the asymmetrically-contoured panels so far described are given in the Table.

Further experiments with 20 in. span inserts were directed to more efficient utilisation of material; results are given in Table XI, for tension only.

4.6 Some factors influencing load capacity

Panels The first two panels, Table X, suffered from incorrect distribution, the amount of Durestos being insufficient, particularly at the centre.

In the second group of three panels the material distribution was better, but still insufficient at the panel centres.

Interplotted contours (See 6.16) gave a more correct distribution, with sufficient material to produce shear failures (Panels No. 6, 8 and 9). These panels attained the 48 tons load considered desirable for the plastic wing rear root attachment.

An attempt was then made to improve efficiency, symmetrical panels being constructed based on theoretical distributions (Fig. 18) and though higher efficiencies were obtained (5.2) the overall quantity of material was somewhat excessive, and load carrying penalised by incorrect splice proportions (6.23).

Inserts

Inserts with varying thickness of splice portions showed that load-carrying was somewhat sensitive to these dimensions. This is to be expected from theoretical considerations, especially with a large insertion depth (Fig. 19).

Tables X and XI show that if the insert tip thickness exceeded 0.030 in. the failing load was appreciably reduced.

With a steel root thickness below 0.065 in. load carrying capacity was also reduced, owing to the effect described at 6.23. The upper limit of root thickness has not so far been investigated, though it is known that the ideal thickness for these panels is about 0.090 in.

5 Interpretation of experimental results

5.1 General load characteristics of steel inserts in vacuum moulded Durestos, from experimental results

The characteristics of steel inserts in Durestos can be gathered from Figs. 19 and 20 where curves of mean shear stress and load per inch of span against depth of insertion, and load against span, have been plotted by extracting from the Tables the mean results of the various sized fishtail inserts.

Depths of insertion

It will be noted that there is a considerable falling off of mean

TABLE XI

20 in. Span inserts in contoured symmetrical panels

Felt contours	Inserts		Falling load in tons	Mean shear stress lb/sq. in.	Mean tensile stress across tips p.s.i.	Mean tensile stress panel centre p.s.i.	Panel eff. F.load /lb.wt /in. panel length	Remarks
	At root of radius in.	At tip in.						
18 - 36	>0.09	>0.03	33.8	473	4200	6800	37.4	Panels cured on shaped female felt-pack with two glass cloth parting layers. All shear failures with good adhesion.
"	0.08	0.02	42.0	587	5220	8450	46.5	
"	0.07	0.01	42.4	593	5270	8560	46.8	
"	0.066	0.01	29.6	414	3650	5975	32.7	
"	0.063	0.01	22.8	319	2830	4600	25.2	
16 - 28	0.095	0.015	40.5	567	5400	9440	45.0	

Common conditions

Steel Inserts

D.T.D. 138A H.T. 80 tons
Depth of insert 4". 1° Nose angle

Durestos

Av. curing time 8 hrs.
Vacuum 28 in. Hg.
Panel size 27" x 42" Glued area 160 sq.in.
Contouring interplotted symmetrical

shear stress (calculated on glued area) with increasing depth of insertion. This confirms the existence of a high stress peak at the tip of the insert with a rapid falling off to a small shear stress over the rest of the insert length. The greater the depth the lower the shear over the after portion.

The curve of load carried per inch of span again confirms this conclusion, as it will be seen that there is no further increase of load beyond about 2 inches of depth.

This characteristic is due to inserts having been made too thick to strain with the Durestos, for with the ideal splice joint (Figs. 21 and 22), theoretically the load should increase uniformly with increase of depth, and thus the shear stress of Durestos would be reached throughout the joint. With increasing span it will be seen that load carrying capacity increases linearly within the range of inserts tested. It is expected that this linear increase of load with span would continue indefinitely.

5.2 Efficiency criterion for insert test panels

Comparative efficiencies on a weight basis can be obtained by using the simple expression:-

Falling load in lb. per lb. wt. of complete panel per inch of panel overall length.

By this means it is possible to compare composite panels with columns of plain material.

Below is given a table of mean values for various panel sizes with efficiencies given as a percentage of that for Durestos in plain tension and compression (longitudinal properties), i.e. 18,000 lb.sq.in. and 13,000 lb.sq.in. respectively.

TABLE XII
Panel efficiency

Insert span in.	Type of panel	Panel efficiency in tension %	Panel efficiency in compression %
-	Plain Durestos	100.0	100.0
2.75	8-felt panel	32.8	-
4	12-felt panel	33.0	-
4	16-felt panel	29.7	50.8
7	semi-contoured panel	27.3	31.7
9.25	" "	34.4	41.0
9.38	" "	46.2	62.0
20.0	" "	37.3	54.5
20.0	fully contoured panel	43.6	-

It should be noted that all test panels have varying degrees of stress diffusion while the comparable Durestos column has none.

By calculating the volume of material in the theoretically ideal opposed point load panel, (see Figs. 30-32, also 6.16), and comparing it with the volume required in a plain column to give the same load, it will be found that for an isotropic material the maximum attainable efficiency is 90% of that of the plain column. However, if the panel

and column were both built up of orthogonal biaxial and uniaxial systems of fibres respectively, the efficiency of the panel would be only 72% that of the plain column since the transverse fibres carry the secondary stress only.

These then are the optimum efficiencies for load diffusion, indicating that point attachments in theory at least need not constitute a heavy structure weight penalty.

On the other hand however, the best test result so far is only a little over half in tension and two thirds in compression of the ideal isotropic panel value. The increase of efficiency in compression is due to the lower compressive properties of Durestos having no effect on the usual type of failure, i.e. shear in Durestos near insert, the strength being substantially the same as in tension.

It will be seen from Table XII that there is a rise of efficiency with grading of panel thickness as would be expected. If allowance is made for weight saved by contouring, there is little change of efficiency with wide variation of panel size.

An attempt was made to compare directly the efficiency of a plastic panel with glued metal inserts and one with metal fittings attached by shear pins.

A plastic panel with an end attachment consisting of two metal plates, one on either side, fastened through the plastic by nine staggered rivets, showed an efficiency of 25.2% whereas a similar-sized panel with the same failing load but with 4 in. span fishtail inserts showed an efficiency of 33%. The achievement of much higher efficiencies for pin joints in plastics would be difficult, whereas the glued joints developed so far are by no means considered the optimum.

For comparative purposes, Table XIII gives typical panel and insert weights

TABLE XIII

Typical panel and insert weights

Span of insert in.	Insert wt lb.	Panel wt lb.	Type of panel
4.0	0.3	2.7	12-felt uniform
9.38	1.2	13.0	7 - 18 contoured asymmetrical
20.0	4.0	40.0	13 - 26 contoured asymmetrical
20.0	4.0	30.0	18 - 36 contoured symmetrical

6 Theoretical analysis of load diffusion

It is convenient to divide theoretical considerations into two sections, the first dealing with problems in the plane of shell structures, and the second with problems through the thickness.

This approach is possible providing the thickness is small, as only then can stresses in the plane and through the thickness be treated as independent systems.

6.1 Analysis of load diffusion in plane panels

In an attempt to arrive at the ideal distribution of material in a panel loaded at a point, an investigation was made of the elastic theory of stress distributions in plane structures. This subject is dealt with in numerous published works^{6,7}.

Before dealing with theoretical distribution it is necessary to investigate the behaviour of materials.

6.1.1 Influence of material on stress distributions

In a plane structure with a single loaded boundary and made of an isotropic material the stress distribution produced is independent of the elastic constants, i.e., Poisson's ratio and elastic modulus.

In solid structures with one or more boundaries, stress distribution is affected only by Poisson's ratio, and even then to a negligible extent.

In other words, similar structures in different isotropic materials would have the same stress distribution as postulated by an elastic theory independent of the elastic constants. This conclusion has been confirmed by the large number of photo-elastic and theoretical distributions which verify each other.

It should be remembered, however, that natural organic materials such as wood, and synthetic laminated plastic similar to that used in the present experiments, are far from isotropic.

How then can we apply theoretical distributions to states of anisotropy?

In plane problems thickness is theoretically zero, and even in practical shell structures it is small compared with the other dimensions, so that high orientation through the thickness can have little influence on the plane distribution of stress. It is the orientation in the plane which can cause considerable discrepancies in the application of theoretical distributions.

Therefore, providing that in the plane the axes of principal stress and strain, and hence principal elastic moduli, are coincident, and the elastic moduli in the principal stress directions are equal, the material behaves isotropically.

Thus it is possible to replace an isotropic plane structure having a given loading and stress distribution by an ideal structure, consisting of highly orientated material arranged with lines of orientation coinciding exactly with the stress trajectories, so that both structures then have similar strain and stress distributions. That this is the ideal structure is borne out biologically, where internal bone formation during growth and with load carrying, consistently develop an orthogonal system of reinforcing filaments⁸.

Assuming the above to be true and providing that structures of anisotropic plastic material conform to one of the three states outlined at 6.13, it was considered that certain theoretical distributions could be applied to them without too much inaccuracy.

6.12 Failure under combined stress

Reinforced plastic materials in general can be termed brittle and therefore follow closely the maximum stress theory which states:- "Failure in a material will occur when any one of the principal stresses reaches the value for simple tension or compression regardless of the value of the other principal stresses". This theory is confirmed in tests of the random-orientated plane mat. Therefore the best distribution of material is greatly simplified in that only the distribution of the separate principal stresses has to be considered for strength.

Most plastics are almost purely elastic. Accurate prediction of stress behaviour by elastic theory is therefore possible, and accordingly alleviation of stress concentrations by plastic flow cannot be expected. Thus it is all the more important that the material be correctly distributed for structural economy.

6.13 Geometry, material properties, and stress relationships

In purely elastic plane problems there are three significant states relating non-uniform distributions of:-

Stress

Geometry (in plane problems - thickness)

Material (mechanical properties, i.e., tension, compression and elastic modulus varying as a single quantity).

State 1: Constant thickness and material properties, but stress varying. This state is identifiable with primitive structures, and with photoelastic models.

State 2: Constant material properties and stress, but thickness varying. This is a more efficient structure, but becomes only approximately true when the thickness gradient is large, producing a three-dimensional stress system.

State 3: Constant stress and thickness but material properties varying, which is probably the structural ideal.

In practice, a combination of any or all three is desirable. State 3, although often found in Nature's load carrying members, has only been made possible to a limited extent in plastics by variation of density, e.g. by moulding pressure (3.12). It can also be approximated in sudden steps by joining several materials of differing properties.

It will be seen therefore, that under given conditions, by keeping any two of the three factors constant the third will always have the same distribution. In other words the stress distribution in state 1 also gives the correct distribution for the variable property in states 2 and 3.

Having arrived at this relation, the formation of various theoretical distributions will now be considered.

6.14 A concentrated load acting on a boundary of a semi-infinite plate (Case 1)

This is the simplest theoretical form of the diffusion problem.

From Fig. 24 it will be seen that the stress trajectories are:-

- (a) Radial lines converging towards the point of application of the load.
- (b) A series of concentric circles with load point as centre.

It should be noted that as one set of stress trajectories takes the form of straight lines, the principal stress Q acting along the concentric circles must theoretically be zero.

Thus the stress pattern fringes (see Fig. 25) can be interpreted as loci of constant principal stress P .

Therefore this stress pattern, comprising a series of circles (of diameters d , $\frac{d}{2}$, $\frac{d}{3}$ etc), tangential to each other at the load point and lying on a common line of centres in the direction of the load, can be interpreted as constant loci of either:-

- (a) Principal stress P
- (b) Thickness
- (c) Material properties

It is important to note that though in practice local distortion of the ideal distribution can occur owing to inaccurate equivalents of point loads, the effect is always negligible at large distances from the loaded area.

6.15 Uniformly distributed load acting on a boundary of a semi-infinite plate (Case 2)

This is a development of the previous case, to simulate more closely the uniform loading applied to a plastic shell by a straight-edged metal insert.

Fig. 27 shows the stress trajectories, consisting of a series of confocal ellipses intersected by an orthogonal system of hyperbolas with common foci at the extremities of the load.

Fig. 28 shows the stress pattern, which is a series of circles intersecting at the extremities of the load; each circle is a locus of $P + Q$. The principal stresses (see Fig. 29) are biaxial tension or compression, and at the loaded boundary these are equal. At the semi-circular fringe the principal stress Q tends toward zero, so that outside of this area the stress pattern can be interpreted as lines of constant principal stress P .

Curves of constant P , Q , and $P - Q$ are also circles intersecting the load at its extremities.

6.16 Analysis of opposed point loads and the formation of a combined stress pattern (Case 3)

It was found for the experimental testing of plastic panels with inserts that the most convenient arrangement was to place two concentrated loads in opposition, forming two stress fields which must be combined.

The combination can be effected graphically (see Figs. 30 and 31) which gives the combined stress trajectories and also the combined stress pattern for $P + Q$.

The construction is simply done by drawing a fresh set of curves through the intersecting points of the two opposed stress systems of Case I, and forming, by addition of one higher with one lower fringe order, fresh curves of constant principal stresses $P + Q$.

It is also possible to obtain a stress pattern for curves of constant Q by interplotting as before the same two systems of tangential circles, thus constructing a series of circular arcs passing through the two load points so that the number of curves crossing the diameter normal to the load direction is equal to half the number of curves of $P + Q$.

Stress patterns of $P - Q$ and P can then be obtained by interplotting patterns of $P + Q$ with those of Q .

It will be recognised that this loading case is that of a circular disc with diametrically opposed loads. The principal stresses are of opposite sign (see Fig. 32) and both principal stresses become zero on the boundary circle.

The stress patterns of $P + Q$, $P - Q$, and P are essentially the same in character owing to the relatively small value of principal stress Q , i.e. $Q = 1/3P$ at the centre of the boundary circle.

6.17 Opposed uniformly distributed loads (Case 4)

This is a development of Case 3 and can be plotted in like manner, by combining two opposed stress systems of Case 2.

Fig. 33 gives the stress trajectories, and Fig. 34 the stress patterns for constant $P + Q$. Fig. 35 gives the distributions on the centre line of principal stresses P and Q , also their sum and difference. At the loaded ends P and Q are like sign but change to opposite sign over the centre portion.

Complete stress patterns for Q can be obtained by interplotting distributions for Q in Cases 2 and 3. By further interplotting of this evolved distribution of Q with the stress pattern for $P + Q$, stress patterns for $P - Q$ and P can be obtained.

A modified form of stress pattern in Fig. 34 was applied in the large test panels.

6.18 Application of stress patterns

(a) To laminated plastics

With laminated plastics which are isotropic in the plane the correct thickness distribution is obtained by directly applying contours of constant principal stress P or Q (whichever is the greater) described at 6.14 to 6.17, as outlines for each successive lamination. With material considerably anisotropic in the plane however the above method cannot be applied.

It was pointed out at 6.11 that in order to conform to the same stress distribution as that for an isotropic material, fibres must lie along the principal stress trajectories.

The most efficient forms of orientation for the three main types of plane stress are as follows:-

- (i) For shear stresses a biaxial orthogonal orientation
- (ii) For uniaxial stresses a uniaxial orientation
- (iii) For a like sign biaxial stress a plain random orientation

For these arrangements of the material the following contours are the correct ones to give the ideal thickness distribution:

- (i) contours of $P - Q$
- (ii) contours of P or Q
- (iii) contours of $P + Q$

For opposite-sign principal stresses there is then the practical difficulty of following the curved stress paths, which might be overcome by using narrow strips of laminate. For like-sign principal stresses it is possible to utilise straight bands of laminations which will give just as efficient an arrangement of material as would result from following an orthogonal system of curved stress trajectories.

For example, in Section 6.15 Case 2 and Fig. 28, the material would consist of straight bands of laminations spreading fanwise at equal angles, each laminate of a different width according to the angle subtended at the loaded edge, so that all lamination edges meet at the extremities of that load. This arrangement gives exactly the same distribution of material as that derived from the circular stress contours of $P + Q$ as it utilises their construction lines as boundaries for the laminations.

The orientation is then uniaxial at large distances from the load where there is a uniaxial stress, merging gradually to a random orientation at the loaded edge where a tensile or compressive biaxial stress exists; this ensures that for all stresses in the structure the corresponding orientations are the most efficient.

(b) To metal inserts

For ease of manufacture the majority of inserts described in this report have been made with a straight loaded edge, to simulate closely the uniform load applied to a straight boundary. Although the stress distribution in the panel is known, the exact state of stress diffusion and optimum configuration for the insert remains unknown, therefore a rough approximation only is possible owing to the varied requirements for mechanical attachment to the insert.

There is, however, no reason why the distribution produced by a point load acting on a boundary (Figs. 19 and 24) cannot be applied to give the correct distribution for both insert and panel using any convenient loci of constant stress as the insert boundary. For constant stress, of course, the correct distribution of material must continue with the insert itself or at least sufficiently so to prevent distortion of the stress distribution occurring in the joint between insert and panel. From Figs. 20 and 31 it will be seen that the ideal shape could be circular.

Providing the specific properties of insert and panel are equal and both their strengths utilised equally, variation of insert size will not affect structural economy. Insert size, therefore, will depend on glue shear considerations only.

6.19 Conclusions

By the methods outlined it has been possible to obtain trajectories and stress patterns of P , Q , $P + Q$, and $P - Q$ for the cases considered. It is also possible to obtain stress distributions for many other combinations of loads by a multiplication of the graphical interplotting process.

It is considered that a graphical stressing system could be developed on these lines which would give a solution more easily than by a purely mathematical approach. It is recognized, however, that for complex loadings and boundary conditions there may be no graphical solution and here relaxation methods⁹, though often lengthy, would be the only solution.

The limitations of experimental resources have rendered possible only partial confirmation of theoretical stress-distributions.

6.2 Analysis through the thickness of the panel at joints between plastic and metal

6.21 Types of adhesive joint

As far as is known at present, adhesives employed for relatively high-strength joints possess inherently lower strengths than those of the materials to be joined. It is necessary, therefore, to place the adhesive in shear in order to increase its cross section compared with the cross section normal to the direct stress in the joining members. Such lap or splice joints have already been studied in detail^{10,11} so their salient features only need be discussed here.

6.22 Stress distribution along the length of the joint

The plain lap joint between two pieces of constant thickness material causes a very high peak stress at the ends of the lap, and it therefore should not be considered for high-strength joints. To obtain the maximum joint strength, the shear stress for any load must be as uniform as possible over the length of the splice. This uniformity can never be achieved completely, because at the boundary, where the adhesive layer ends, the normal principal stress must always be zero. A state of plain tension or compression only can exist along a boundary. It should be contrived, however, that this boundary stress should not greatly exceed the principal components of shear in the adhesive.

As far as is known at present for isotropic materials the straight tapered scarf joint is nearest to the theoretical ideal.

6.23 Stress distribution in joints between two materials of different elastic moduli

To obtain a uniform shear in the composite joint the strain distribution in the two materials must be sensibly equal and constant over the length of the splice for all values of load up to failure. This is achieved by making the thickness at the ends of the splice in inverse proportion to their effective elastic moduli, see Fig. 21. If both materials are to reach their ultimate strengths simultaneously these must be in the same ratio as the elastic moduli. For further discussion of this matter, see Section 7.1.

It should be noted that the ideal splice of Fig. 21 will become modified when applied to a state of load diffusion for the joint will then occur in a section of varying thickness, (see Figs. 26 and 29) the splice becoming superimposed on a curved distribution producing an increase in the thickness of the high modulus material relative to the thickness of the low modulus material (see Fig. 22).

An incorrect ratio between the two material thicknesses at the ends of the splice will cause the radial stress trajectories to change direction at the sharp edge; this increases or decreases the diffusion locally with the adverse effect of producing in the plane secondary stresses normal to the radial stresses in the vital glued joint area.

6.24 Types of insert

A number of inserts placed one above another and interspaced with laminations of plastics are unlikely to show any advantage structurally over a single insert, being in principle only a multiplication of them.

Theoretically, in their best form multiple inserts would consist of extremely thin laminations, but with plastics giving off volatiles during cure there would be a considerable ventilation problem. Also, the coalescence of thin metal laminations into an integral boss has practical difficulties.

It appears therefore, that multiple inserts will be limited in application to extra thick sections of limited span and from which there is little diffusion. However the principle of using an assembly of thin laminates to form a correctly contoured single insert should be quite practicable.

Where a large diffusion is required, as in all shell structures with point loads, a single insert will always have the advantage over the inevitably thicker assembly of an equivalent multiple insert, for the latter will produce a steeper inclination of stress trajectories to the applied load in the plastic outboard of the insert, thus making less efficient use of material.

There is another insert type which is worth consideration, especially in high pressure mouldings. It consists of a single plate formed into corrugations which spread radially from the boss. The advantages are increased surface area, and better stress distribution in the joint through the thickness. The disadvantage is difficulty of manufacture.

7 Materials for load diffusion

7.1 Mechanical properties of materials to be joined Metals compared with Durestos

In determining the behaviour of joints between dissimilar materials it is necessary to compare their stress-strain curves. Typical tension curves of several steels, aluminium and magnesium alloys have been plotted against a typical stress-strain curve of Durestos. See Figs. 36 and 37.

To secure the best compromise between the strain and the failing strengths of the two materials which could occur in a splice joint, Durestos curves have been superimposed on those of the metals by using a different stress scale. The ratio of these scales will represent the ratio of the material thicknesses at the ends of the splice, see Fig. 21.

Fig. 36 shows superimposed curves for Durestos, spring steel to Spec. D.T.D.138A, H.T. steel S.28, and D.T.D.331, also mild steel S.1.

It will be seen that by making the Durestos section twelve times that of the H.T. steels only a small differential strain is caused.

For the optimum use of Durestos properties, it appears that higher strength steels than were used for these experiments would be advantageous.

By comparison it will be noted that if Durestos is given the same strain as mild steel up to its yield point the steel will reach failure while the Durestos is only stressed to 15% - 20% of its failing load.

Alternatively, if the Durestos section is reduced to three times that of mild steel so that the two materials reach failure together, a differential strain equal to half the maximum strain at failure will occur in the joint, the equivalent of causing a very considerable stress concentration at the nose of the steel insert.

Therefore, low strength steels are considered very undesirable for inserts in primary structures made of plastics similar to Durestos. It is preferable where a lower strength insert is sufficient to use one of the light alloys, (see Fig. 19). Where aluminium alloy D.T.D. 683 and magnesium Z;Z curves are plotted with that of Durestos having the equivalent sections of 4.5 and 2.5 times that of the alloys respectively, a very close matching of the stress-strain curves is obtained.

The above comparisons have been made with no consideration of the effects of thermal expansion, (see 7.5).

7.2 Properties of Durestos

The plastic material used for the experiments described in this report has structural properties which are far from ideal, being a plane mat of fibres orientated longitudinally to transversely in the ratio of 3 to 2 and with tension greater than compression in either direction in about the same ratio. Through the thickness the material consists of a highly orientated arrangement of fibres with a very low tension strength normal to the plane.

The moduli of elasticity for the three principal axes are roughly proportional to the strengths.

The material also suffers from a scatter of properties due to variation of moulding pressure. Fortunately strength and stiffness vary together; hence weaker portions do not reach failure before the stronger portions.

7.3 Application of Durestos to panels with inserts

7.31 In the plane of the panel

Durestos laminations should have the longitudinal properties in alignment with the radial stress trajectories which converge on the insert. For an insert from which there is little diffusion, an alignment of all laminations parallel to the load direction is probably sufficient.

7.32 In the thickness of the panel

Theoretically, the best arrangement of fibres through the thickness at a splice joint is that shown in Fig. 21, the fibres following the trajectories of the major principal stress.

The properties of an anisotropic material at various inclinations to the major axes conform approximately to the relationship

$$N = \frac{PQ}{P \sin^2 \theta + Q \cos^2 \theta}$$

where N is the property at some angle θ to P, P and Q being the two principal properties.

This relation is plotted, (see Fig. 38), to show the variation of Durestos tensile strength with angle to the fibre axis through the thickness.

It will be seen that a considerable drop in tensile strength occurs when the angle between load direction and main axial tension is relatively small. Hence the importance of alignment of fibres with the principal stresses in highly orientated materials.

7.4 Effect of thermal expansion on stress between different materials

Metal inserts are bonded into Durestos or other heat-cured plastics, at 150°C, and at this temperature there exists a condition of no strain.

On cooling, however, owing to the different coefficients of expansion an increasing differential strain and hence residual stress will develop in the joint. The magnitude of the strain was therefore investigated for the greatest temperature range likely to be imposed on plastic structures, i.e. 220°C.

Durestos coefficients of expansion vary for all three axes in approximately the same ratio as the inverses of the respective elastic moduli¹². The coefficient normal to the laminations is 9.35 and 5.1 times the respective plane coefficients. This normal direction will not be considered as the thickness of shell structures is small.

Below is given the differential strain between Durestos (longitudinal expansion) and three metals for temperatures of 20°C and -70°C; the strain quoted is a percentage of the average strain at failure for these materials, i.e. 1.0% elongation.

	<u>20°C</u>	<u>-70°C</u>
80 ton spring steel and Durestos	5.4%	13.2%
35 ton Duralumin and Durestos	16.4%	40.0%
20 ton magnesium and Durestos	18.0%	44.0%

These figures may be a little severe as they do not account for any plasticity of glue and Durestos resin during cooling from 150°C which would have the effect of alleviating some of this strain.

It appears from these figures that metal inserts of magnesium or aluminium alloys, while capable of matching Durestos from stress-strain and strength points of view, (see 7.1), will suffer severe residual stresses at low temperatures which may make them unsuitable for moulding into thermo-setting plastics.

In a splice joint with the ideal fibre arrangement through the thickness, (see 7.32) the fibres will subtend some small angle to the insert surface, thus favourably modifying the effective Durestos coefficient of expansion relative to the insert.

By using the relation given in Section 7.32 and substituting for mechanical properties inverses of the thermal expansions, effective expansion at any angle θ may be obtained.

8 Point attachments for large plastic structures

8.1 Applications to the plastic wing

Inserts of the type described in Section 4.1 were used to obtain a four-point fuselage attachment of a plastic Delta wing, using one 20-inch span and one 9-inch span insert in both top and bottom wing skins, (see Fig. 39).

The inserts were attached to machined forgings which bridged between top and bottom insert pairs, providing at the same time a vertical shear pick-up to the fuselage.

Thus inserts carry only tension and compression loads fed to them under wing bending.

The fully factored load required for rear inserts was 36 tons each and for front inserts 15.3 tons, but it was considered desirable to have some further reserve on the shear strength of these joints, and panel tests were accordingly developed to give 48 and 21 tons respectively.

It should be noted that panel thickness had to be sufficient to cause a shear failure at this figure although wing design skin thickness was required to diffuse 75% of these latter loads. Thus wing inserts had a shear area reserve of 1.33.

Load diffusion from inserts in this wing structure was complicated by a shear web structure of somewhat unusual form (Fig. 40) which made direct theoretical analysis of skin contours extremely difficult and only an approximate grading of skins was possible, particularly when strength requirements for the wing included a wide variety of airload distributions.

It will be seen also that similar inserts of smaller size are positioned for an anchorage of the elevon control surface hinges.

8.2 Insert packs for sub-assembly

It was found that for large mouldings such as the plastic Delta wing, gluing up of inserts was best accomplished by sub-assembling them into their correct position in the local surrounding laminations (see Plate 41) and partially consolidating by preheating in a small vacuum rig, as explained at 4.3.

8.3 Location of inserts during vacuum moulding

In order to obtain accurate location of all point attachments a suitable jig incorporating fastenings to all inserts is essential.

Laminated Durestos during cure reduces finally to about 50% of its original thickness which causes metal inserts to move normal to the laminations. This difficulty in jiggling of inserts can be overcome by incorporating a screw jack or similar device into the jig which can be adjusted during moulding to the final dimension required (see also 3.12; end). Sub-assembly of inserts greatly facilitates attachment to the jig.

9 Recommendations for future work

9.1 Basic information on material physical properties

Research into structures containing new materials is almost wholly dependent on the degree to which the material properties are known. It is felt that before much further advance can be made into solving the problems of glued joints, a more comprehensive knowledge of the behaviour of resins and fibrous materials is required.

9.2 Use of new materials

It is foreseen that the solution to the load diffusion problem as formulated here might well be applied to many other structural materials.

Glass fibre laminates which incorporate cold-setting resins give rise to a special problem with metal inserts, for the adhesion of these resins to metals is usually poor.

The problem might be overcome either

- (a) By special surface treatment of the metal, or
- (b) By pre-coating and curing a hot-setting resin on to the metal surface.

An alternative solution might be the gluing of Durestos to metal with thermo-setting resin, and then treating such an assembly as an 'insert' for incorporation into cold-setting resin structures.

From a stressing viewpoint glass laminates present the difficulty of matching the low elastic modulus and high strength, and hence high strain at failure, with similar suitable properties in a metal. Investigation of metals reveals that high strength titanium alloys seem to be the only ones likely to be really suitable if high joint efficiencies are required. For structures requiring only moderate degrees of diffusion, and where lower joint efficiencies are acceptable, light alloy inserts would be worth investigation.

The desire for further gains in structural weight economy may necessitate the application of highly orientated fibre materials into the optimum arrangements for load diffusion, i.e. radial bands of laminates and laying of fibres to curved stress trajectories.

9.3 Diffusion of even larger point loads

It is realised that loads greatly in excess of those already achieved may be required for large plastic structures. Although there is no reason to suppose that manufacture of inserts to carry loads exceeding 50 tons would be unduly difficult, further experiments would be desirable.

9.4 Further work

Other characteristics of plastic to metal glued joints on which further information is necessary are listed below:-

Inserts in high pressure mouldings

Experimental stress analysis of loaded inserts

Resistance of glued inserts to adverse conditions such as:

- (a) Repeated loading, fatigue, and creep over high and low temperature ranges, and
- (b) the effect of solvents, fuels, oils etc on load capacity.

10 Conclusions

The efficient diffusion of relatively large concentrated loads into comparatively thin reinforced plastic skins and shell structures has proved quite practicable, though less easy theoretically or experimentally than at first anticipated.

Tension and compression point-loads exceeding 50 tons have been achieved by simultaneous gluing and vacuum-moulding of specially shaped steel inserts into asbestos-reinforced P.F. laminated structural material.

Satisfactory strength characteristics of plastic to metal joints were shown over the temperature range -80°C to $+90^{\circ}\text{C}$, with a drop of about 20% immediately after wetting and exposure, with consistent failure by shear in the plastic away from the glue line, with no disturbance of the glue bond to the metal.

Correct choice of materials, splice proportions of metal and plastic, span and sharpness of inserts have far more influence on load capacity than variations of moulding technique.

A detailed study of load diffusion problems from the general viewpoint of elastic theory, involving theoretical analysis and graphical solutions for determination of the ideal distribution of material, have given new information of general applicability.

Acknowledgement

The Authors wish to acknowledge the assistance of Mr. E.F.J. Ashley in the whole of the experimental work, requiring difficult skilled techniques.

REFERENCES

<u>Ref.No.</u>	<u>Author</u>	<u>Title, etc.</u>
1	J.E. Gordon and C.G. Evans	Second Progress Report on R.A.E. plastic smooth wing. R.A.E. Report Chem 444 ARC 11,724. June, 1948
2	P.H.H. Bishop	Some factors affecting strength and stiffness of moulded "Durestos". R.A.E. Technical Note Chem 1071 Appendix I
3	P.L. McMullen	The effect of variation in resin content on the strength and stiffness of moulded "Durestos". R.A.E. Technical Note Chem 1119 ARC 12,901. December, 1949
4	H.F. Downton	The mechanical properties of vacuum- moulded "Durestos" at various temperatures. R.A.E. Report Chem 451 ARC 12,261. January, 1949
5	G.S. Learmonth	"The bonding of friction fabrics". (Structural Adhesives: the theory and practice of gluing with synthetic resins) Lange Maxwell and Springer Dec. 1951 pp 193-4
6	M.M. Frocht	Photoelasticity Vols. 1 & 2. John Wiley and Son Inc. Chapman and Hall, London 1941 and 1948
7	S. Timoshenko	Theory of Elasticity. McGraw Hill Book Co. New York & London 1934
8	D'Arcy W. Thompson	Growth and Form. Cambridge University Press. 1942
9	R.V. Southwell	Relaxation Methods. Cambridge University Press. 1942
10	N.A. de Bruyne , and R. Houwink	Adhesion and Adhesives. Elsevier Publishing Co. London, 1951

REFERENCES (Contd)

<u>No.</u>	<u>Author</u>	<u>Title etc.</u>
11	M. Goland and E. Reisner	Theory of scarf and lap joints. Journal of Applied Mechanics. No. 11 P. 417 1944
12	P.J. Mettam	Preliminary determination of the linear coefficients of expansion of Vacuum moulded Durestos Tech. Note Chem 1113 ARC 12,982. November, 1949.

APPENDIX I

Rate of loading of insert test panels

For the usual tension and compression tests, rate of loading (or alternatively strain rate) is specified for reproducibility of test conditions. In the work described, insert test panel size varied widely, hence the use of several testing machines.

As a rough check on sensitivity or otherwise to loading rate of such non-standard test pieces, six exactly similar 16-felt panels each $14\frac{1}{2}$ inches by 8 inches with opposed 4 inch span steel inserts, were pulled in two machines, one purely mechanical, the other hydraulic; the latter being capable of wide loading rate adjustment. Results were as follows:-

TABLE XIV

Rate of loading

Panel No.	Failing load of insert tons	Mean shear stress p.s.i.	Time of load application Sec.	Average rate of loading tons/min	Machine
1	7.54	2110	170	3.77	10 ton Olsen (Mech. drive)
2	6.9	1930	50	8.3	
3	6.8	1900	45	9.07	
4	6.9	1930	8	51.8	30-ton Avery (Hydraulic) 15-ton range
5	7.2	2080	8	54.0	
6	7.2	2080	8	54.0	

All failures were of similar type i.e. shear in the Durestos. Hence for rates of loading within the range 3.75 to 54 tons/min (1:14.3) failing loads were little affected, the usual scatter of course being evident.

The more conveniently applied lowest loading rate was used for 4-inch span inserts.

For large inserts and panels tested in a 200 ton Avery machine (100 ton range) a higher rate of loading, 15 - 16 tons/min was employed throughout so that on the basis of "time to failure" ($2\frac{1}{2}$ - 3 min) for all tests, both in tension and compression, straining rates were comparable.

APPENDIX II

Large span steel inserts

Inserts were cut from 0.3 in. thick sheet steel to Spec. D.T.D. 138A, the most easily obtainable steel which matched the Durestos properties. (See 7.1). The faces were flattened, ground and profile-machined to the section shown in Fig.23, but with a bead left along the tip to facilitate heat treatment (see Fig.7). All holes were drilled prior to heat treatment, which was 850°C oil quench, 430°C water quench giving a tensile strength of about 80 tons/sq.in. It was then necessary to correct distortion and when required, curve slightly to wing profile.

Final finishing consisted of sand blasting followed by mechanical sanding with an aluminium oxide resin-bonded disc, then degreasing just prior to use.

Although phosphoric acid etch or similar treatment might well increase glue adhesion, this is unnecessary in view of all failure occurring in the plastic.

If it is required to remove inserts for re-use, experience suggests that it is not advisable to loosen the plastic with caustic soda. Removal can best be achieved by splitting down the laminations and sanding off the excess. Other suitable insert materials are given at 7.1 and 9.2 and their respective manufacturing techniques would need development accordingly.

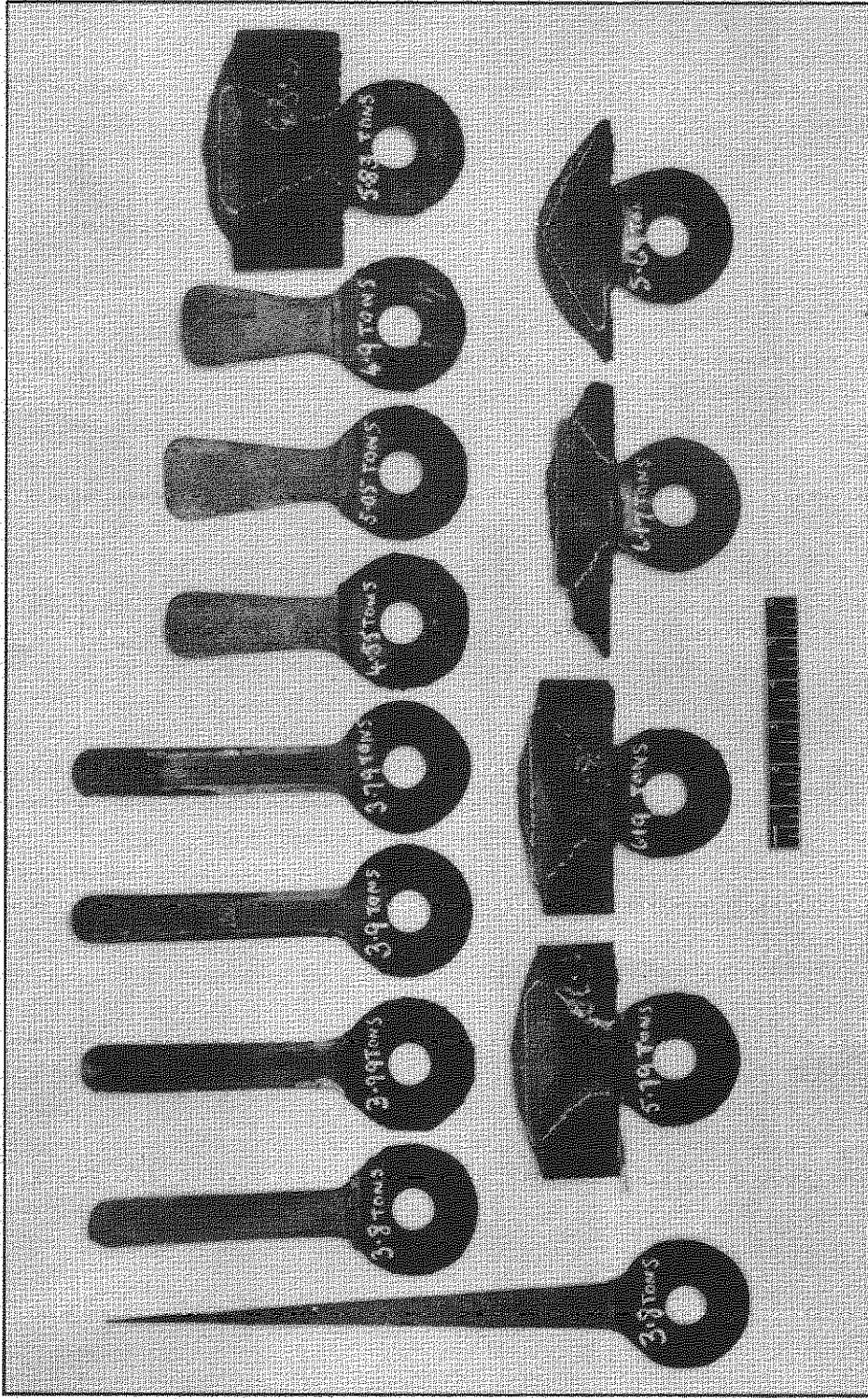

FIG.1. PROGRESSIVE DEVELOPMENT OF INSERT SHAPES

FIG.2

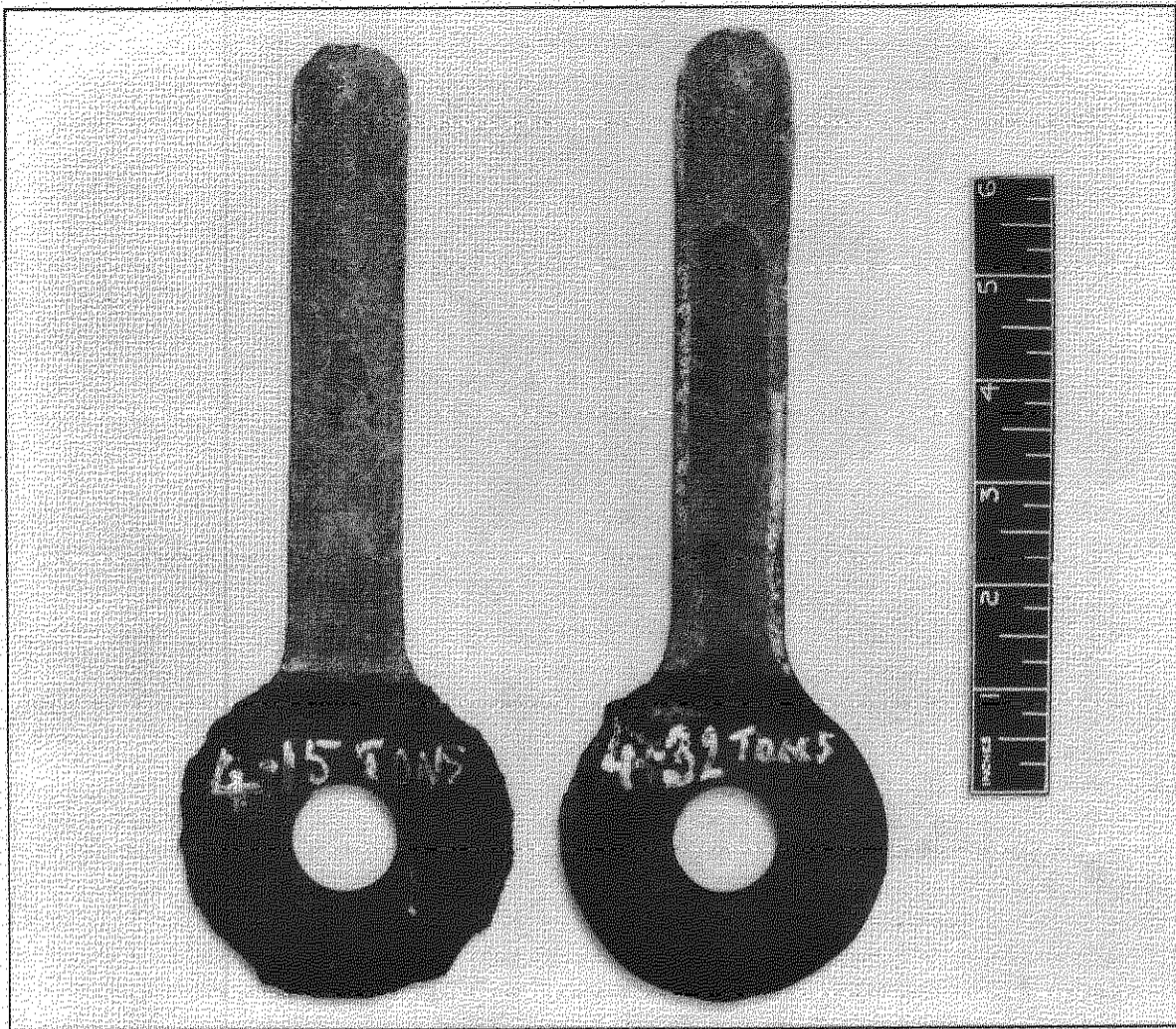

FIG.2a. GOOD AND IMPERFECT ADHESION

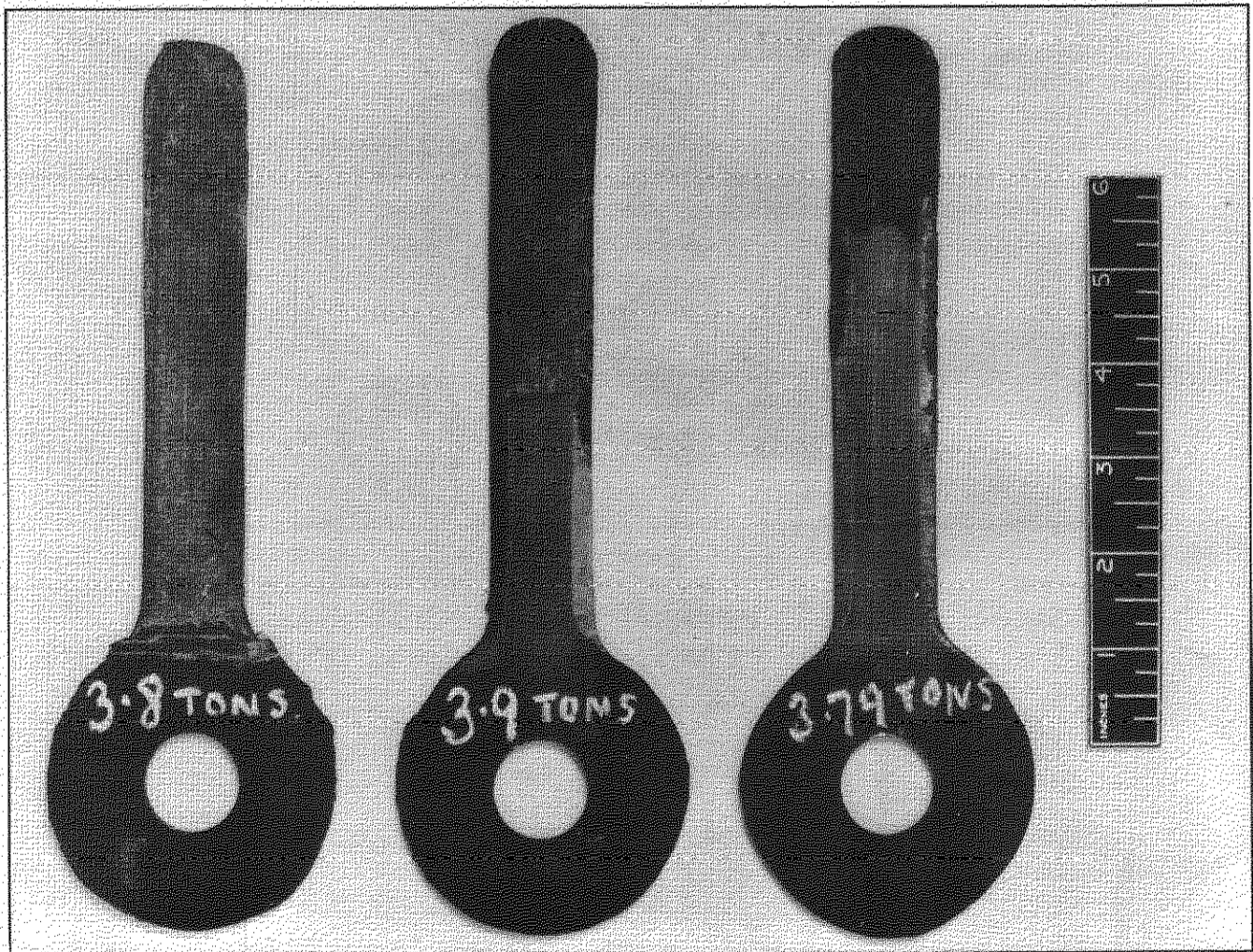

FIG.2b. VARIATION OF EFFECTIVE INSERTION DEPTH

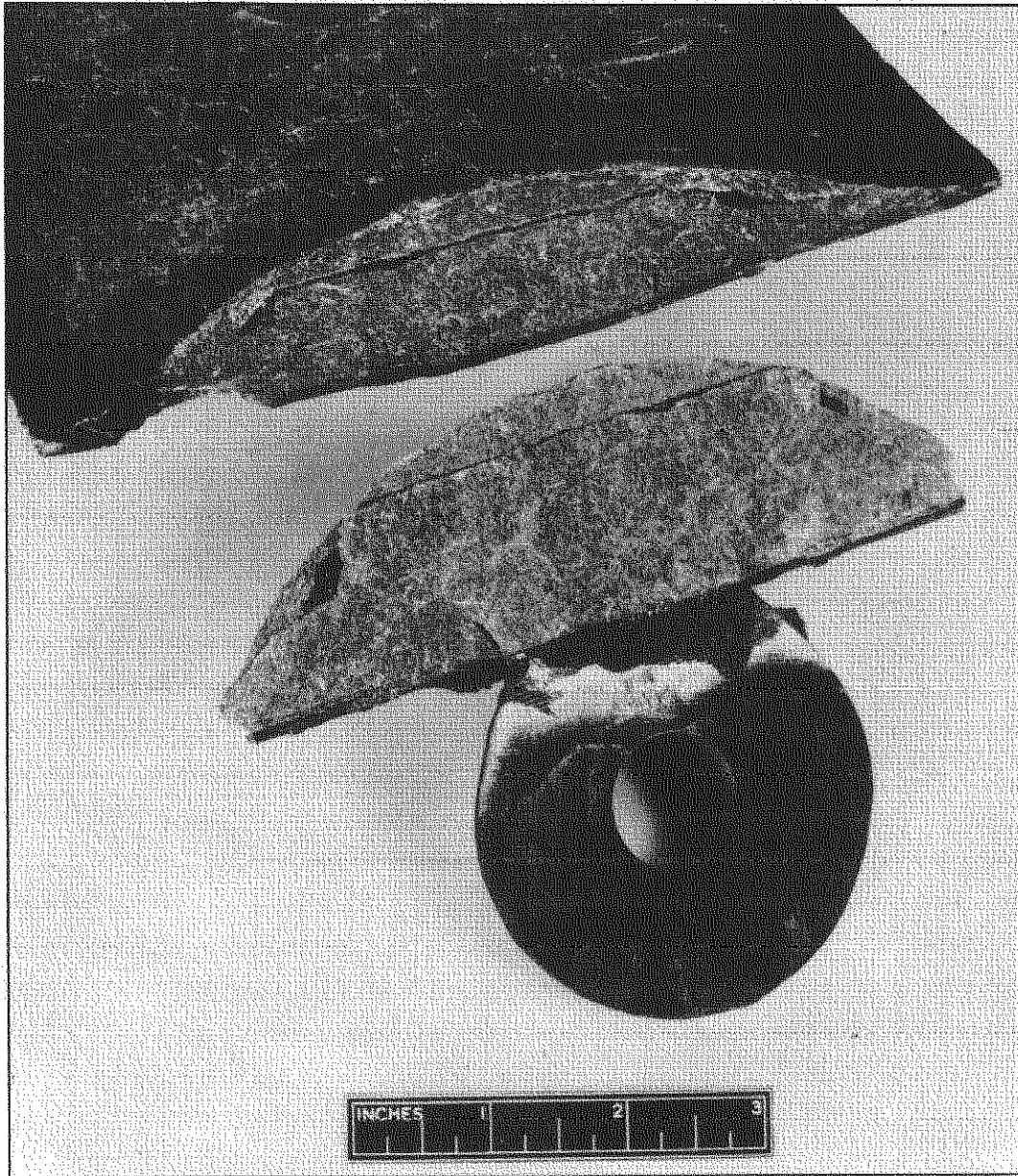

FIG.3a. SHEAR AND TENSION FAILURE AT 8.2 TONS



FIG.3b. TENSION FAILURE AT 8.02 TONS

FIG.3(cont'd.)

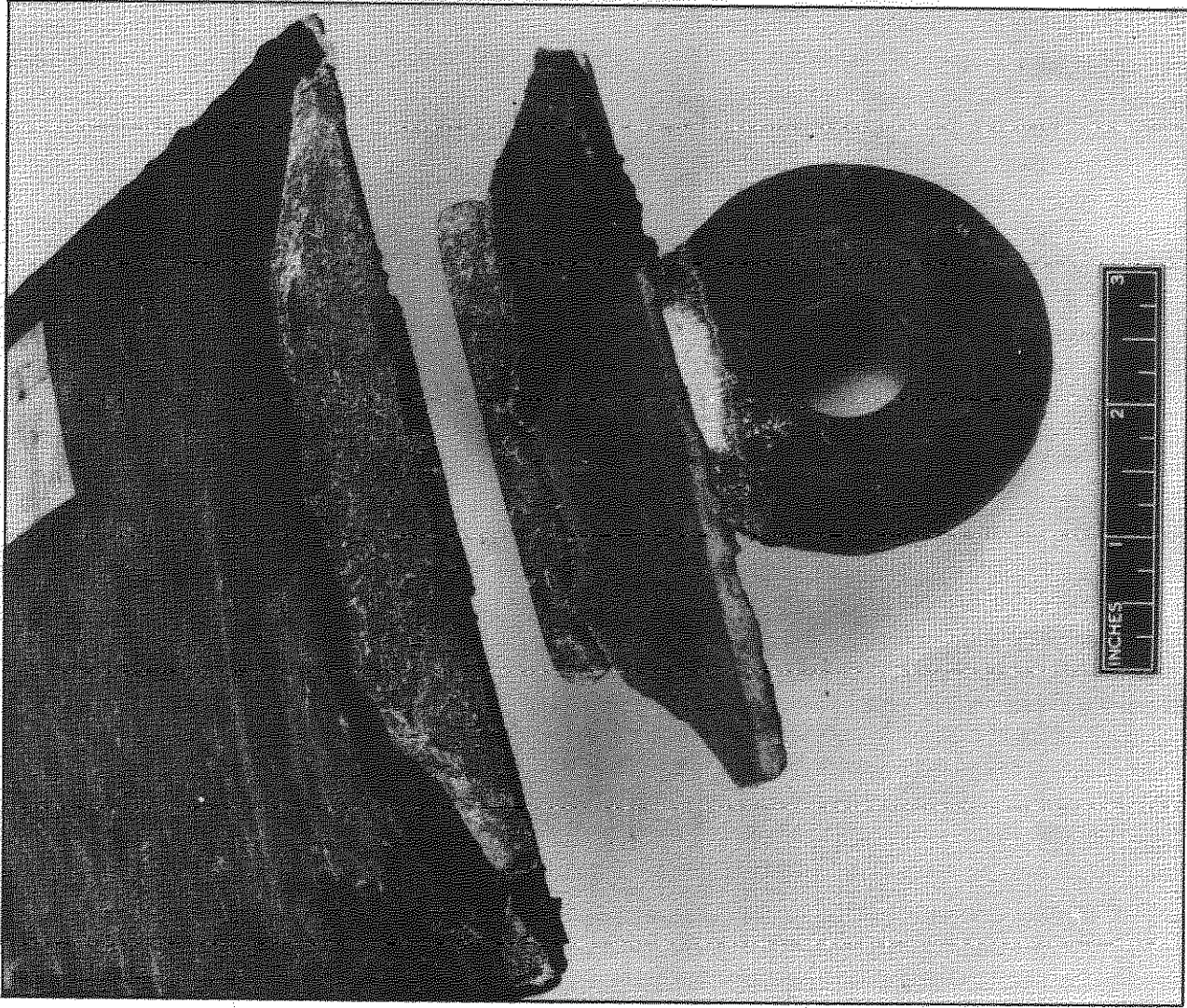

FIG.3d. PRE-PRESSED PANEL. FAILING LOAD 9.5 TONS

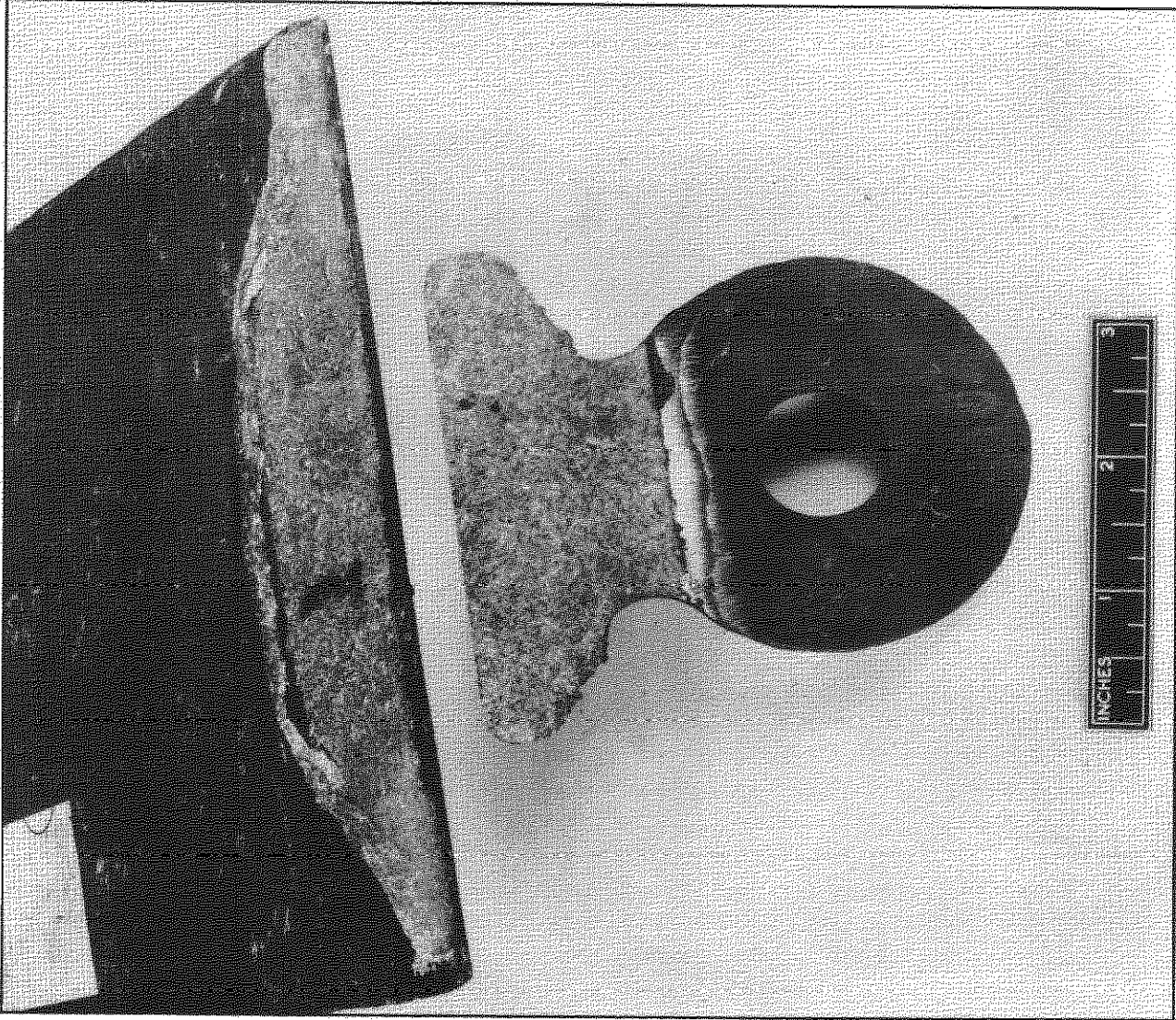

FIG.3c. SHEAR AND TENSION FAILURE AT 9.12 TONS

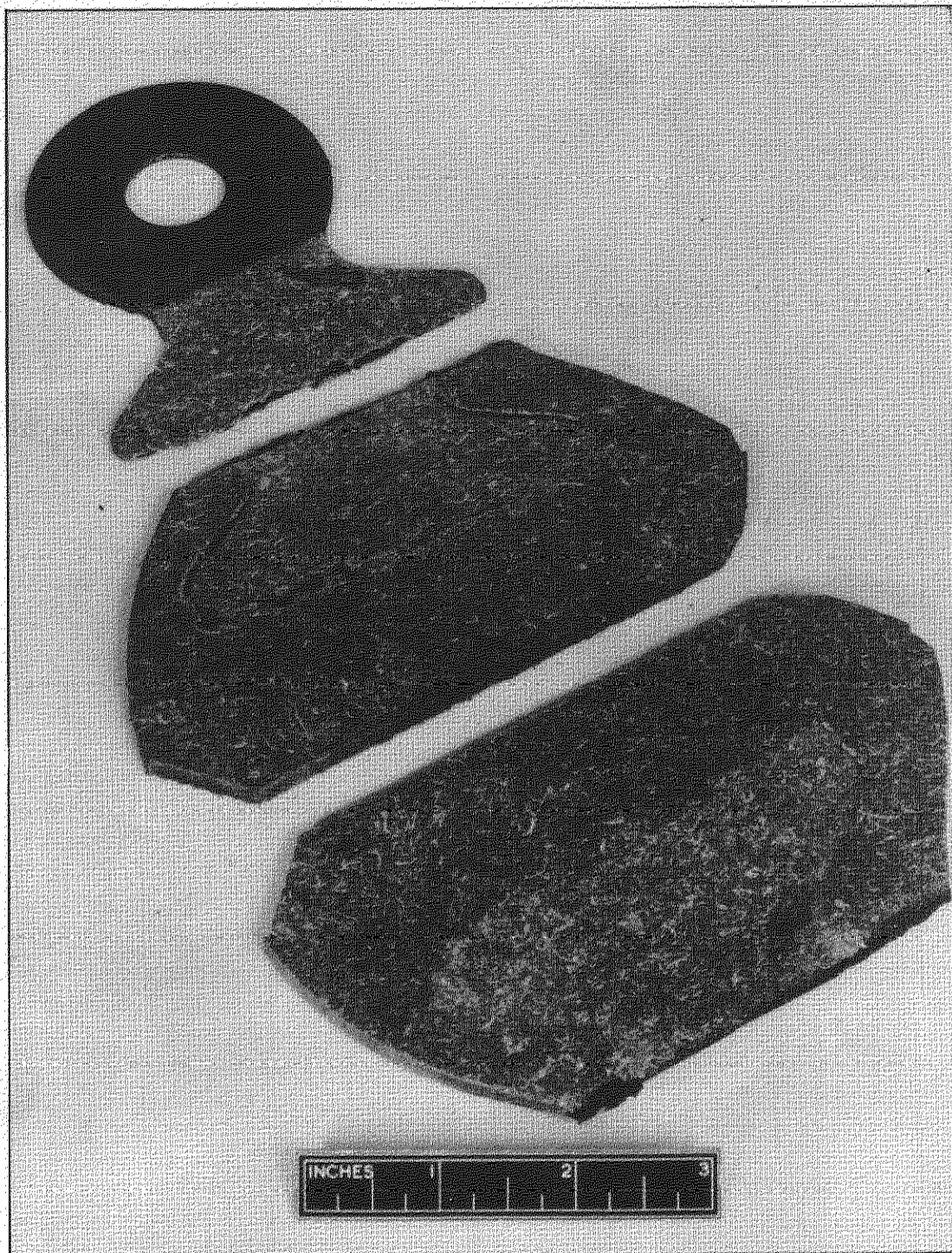

FIG.4. SHEAR FAILURE AT 9.3 TONS OF A
4 in. SPAN INSERT COMPRESSION PANEL



FIG.5. SHEAR FAILURE AT 22.5 TONS OF
9.38 in. SPAN INSERT COMPRESSION PANEL



FIG.6. REVERSE SIDE OF INSERT

FIG.5 & 6

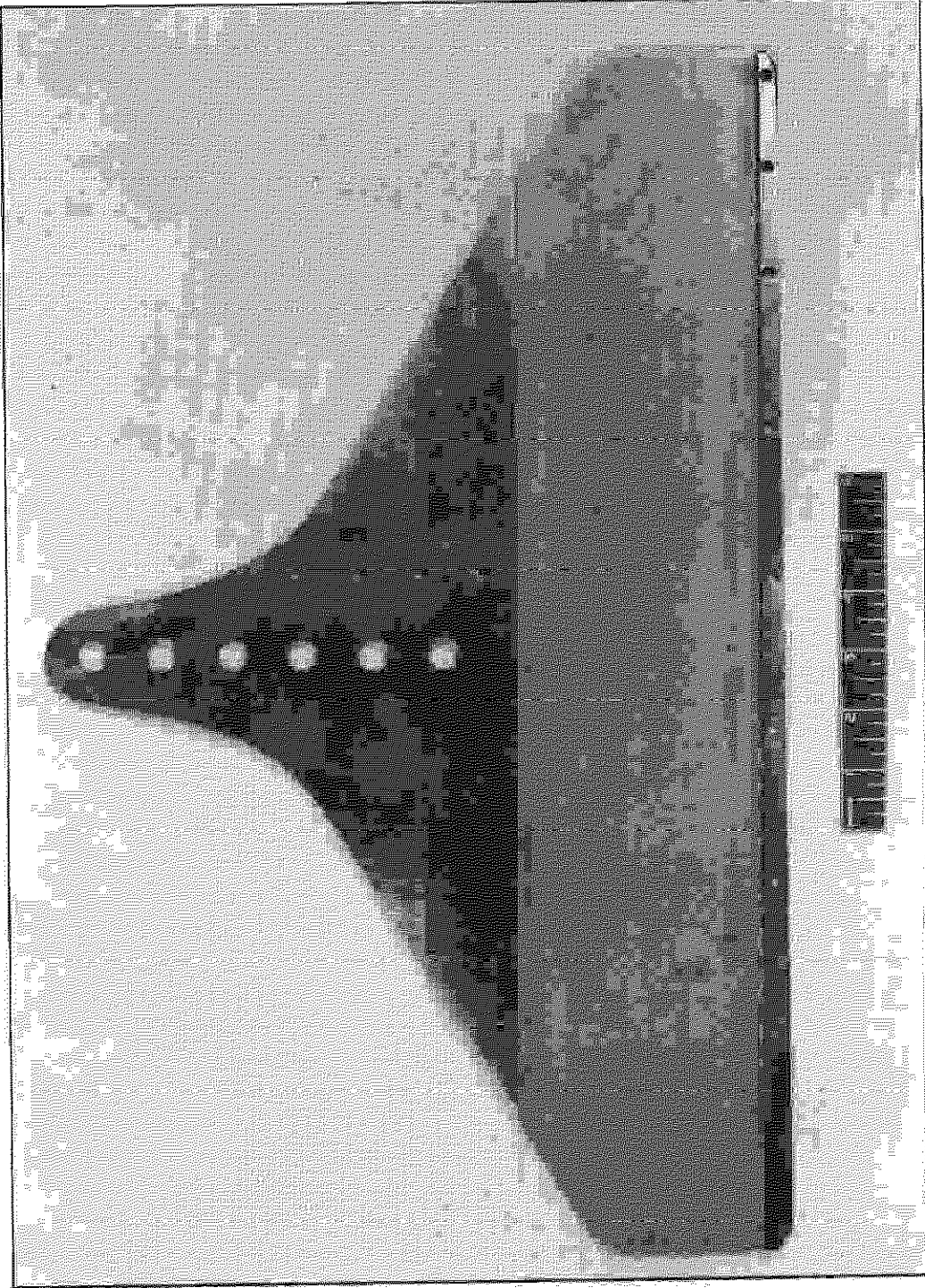

FIG.7. 20 in. SPAN FISHTAIL INSERT, PROFILE-MACHINED WITH 1° NOSE ANGLE

FIG.8

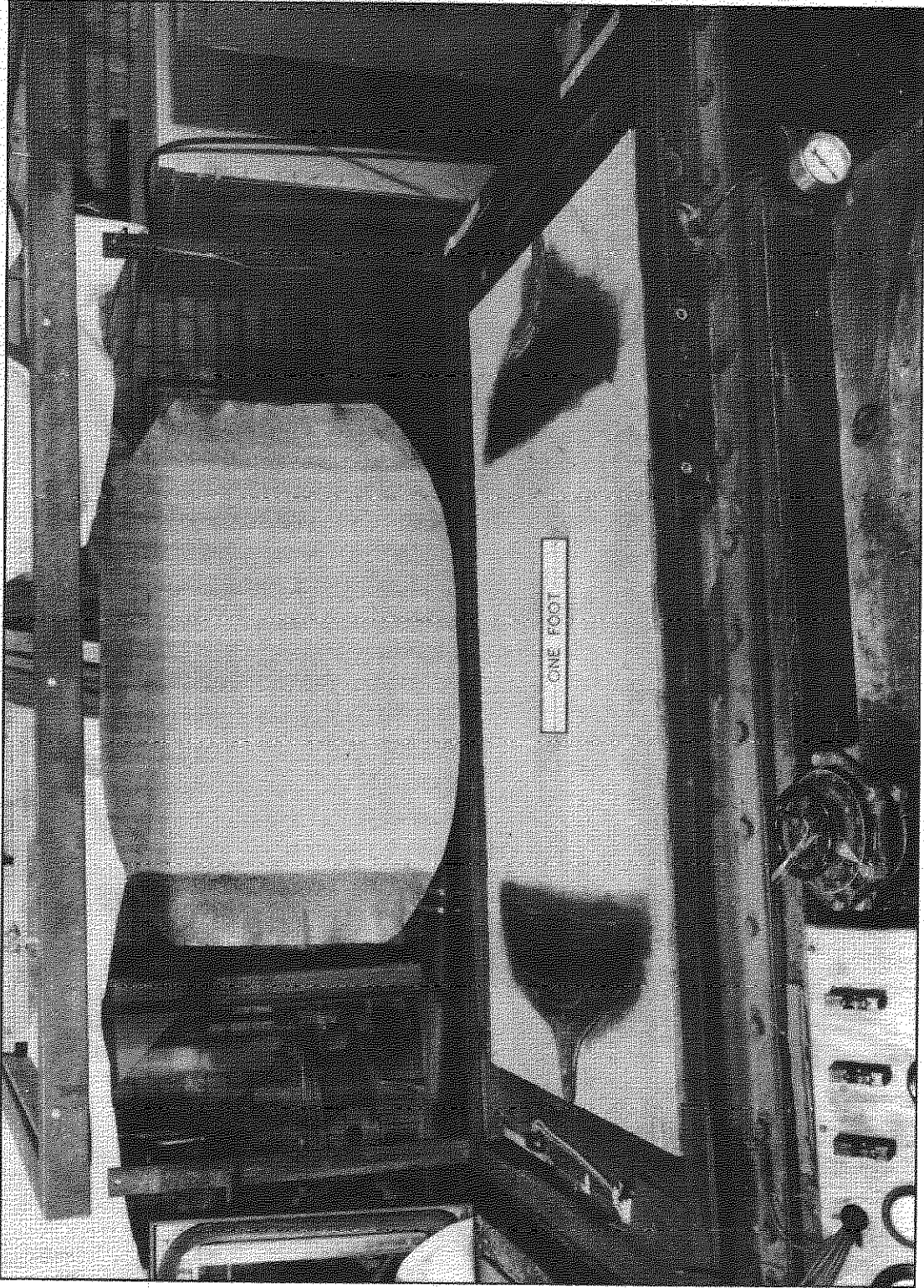

FIG.8. PANEL ASSEMBLY SHOWING INTRODUCTION OF GLUED INSERTS

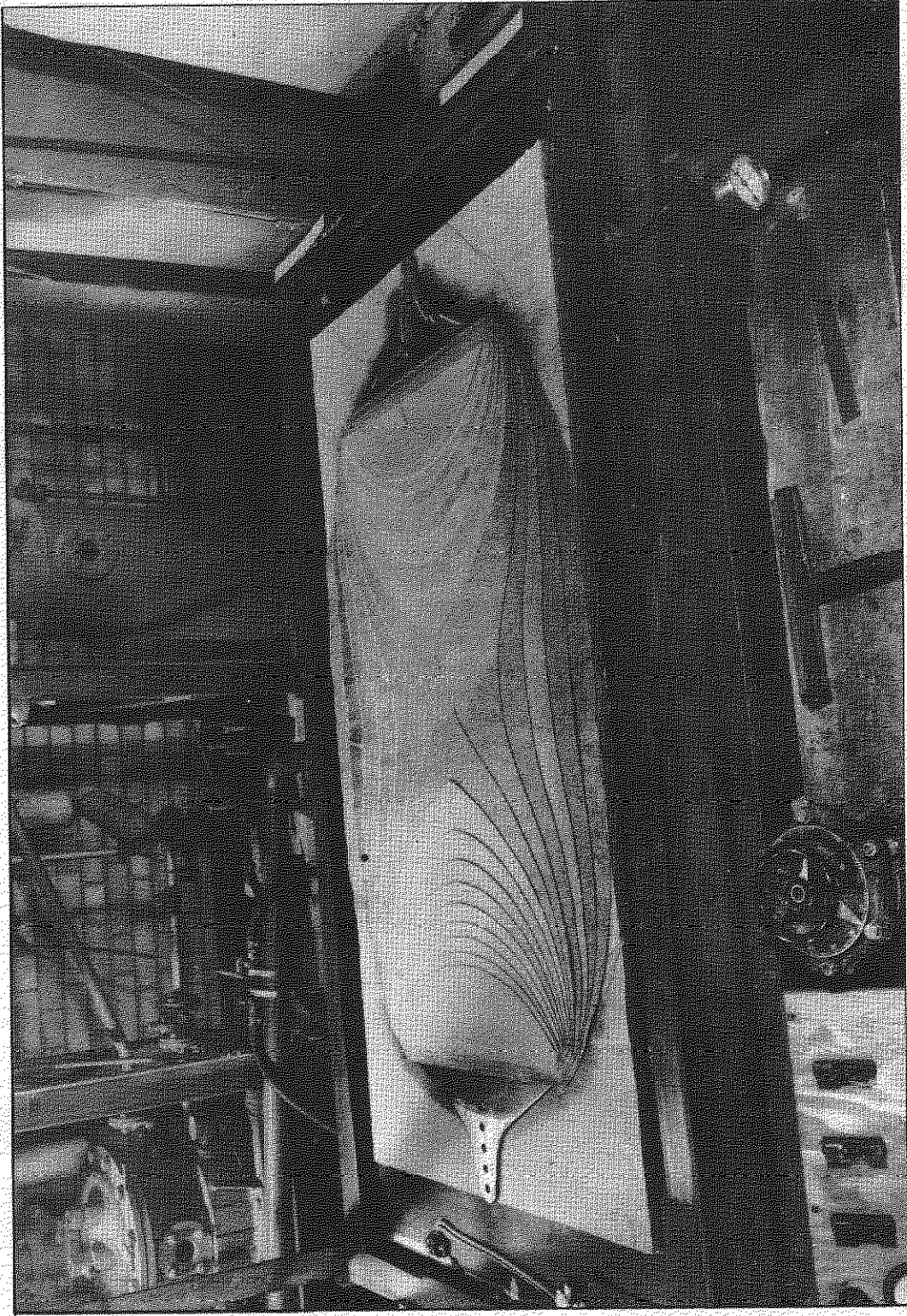

FIG.9. CONTOURED FELT ASSEMBLY COMPLETED

FIG.10

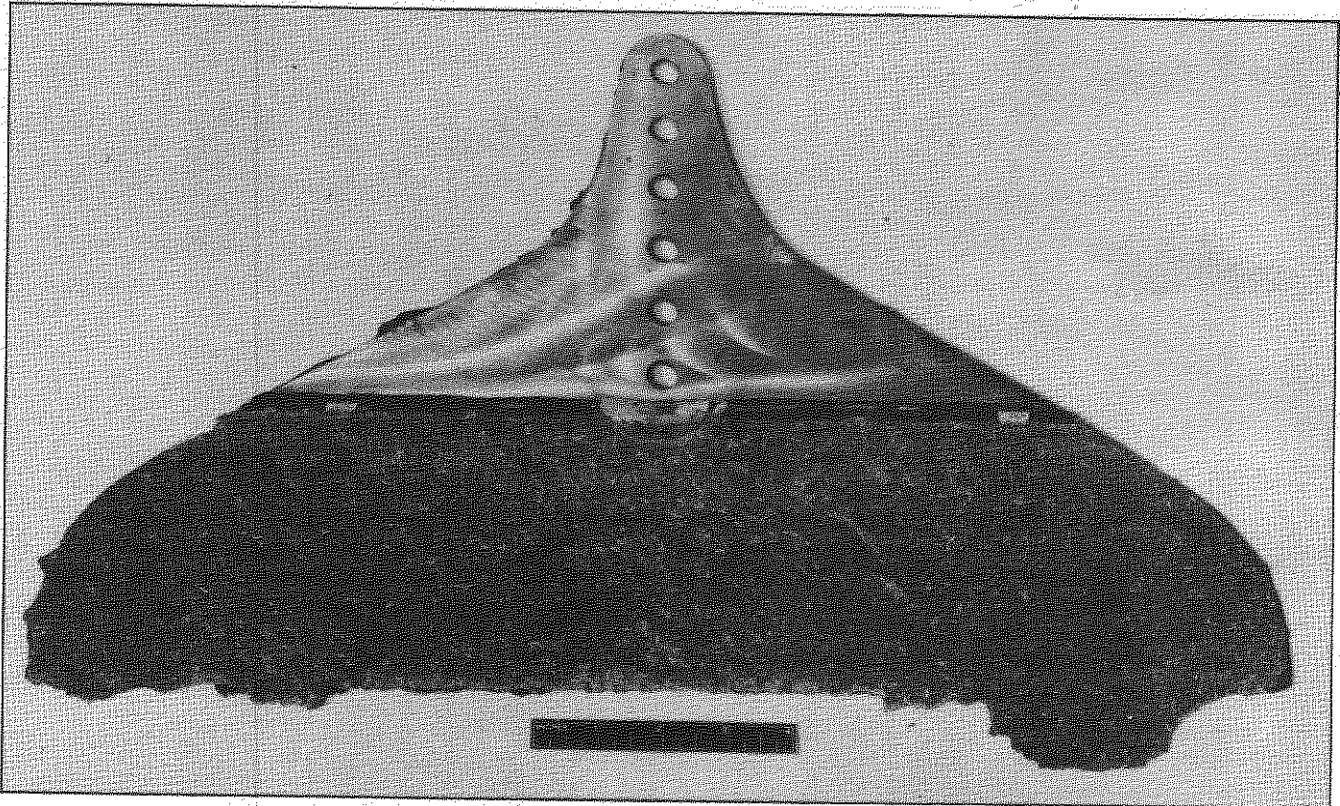

FIG.10a. WELL VENTILATED TOP SURFACE

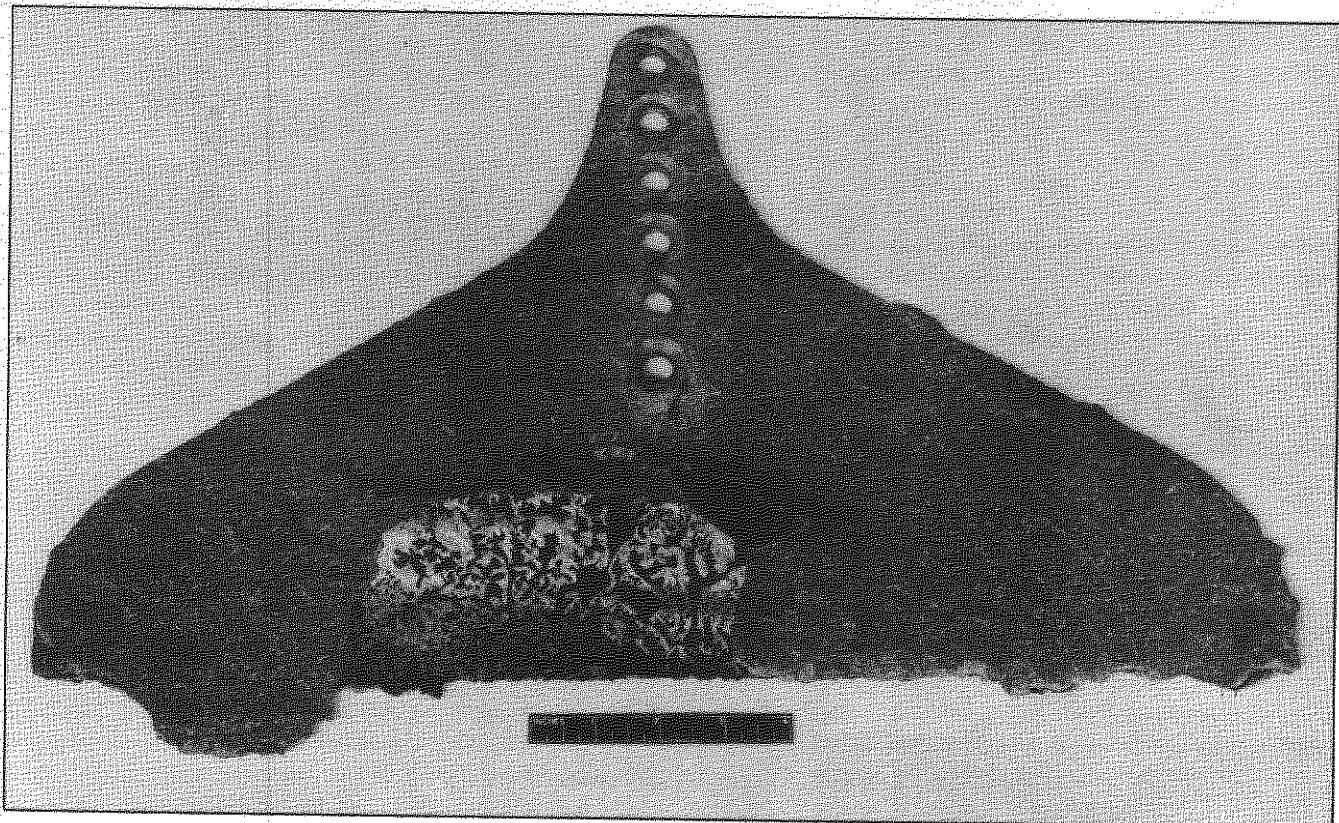

FIG.10b. BADLY VENTILATED UNDER SURFACE

FIG.10a & b. 20 in. SPAN INSERT

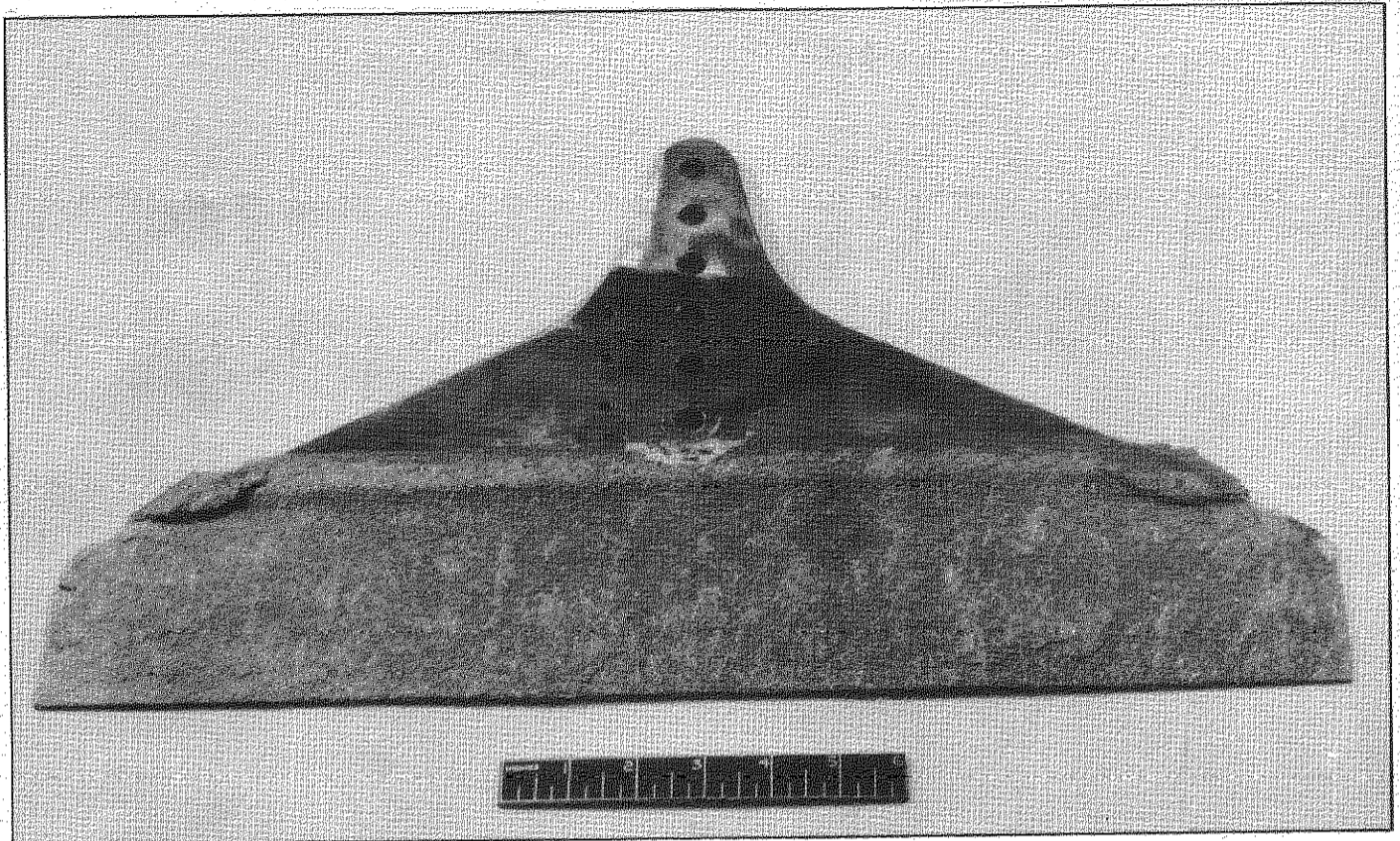

FIG.11a. GOOD VENTILATION, TOP SURFACE

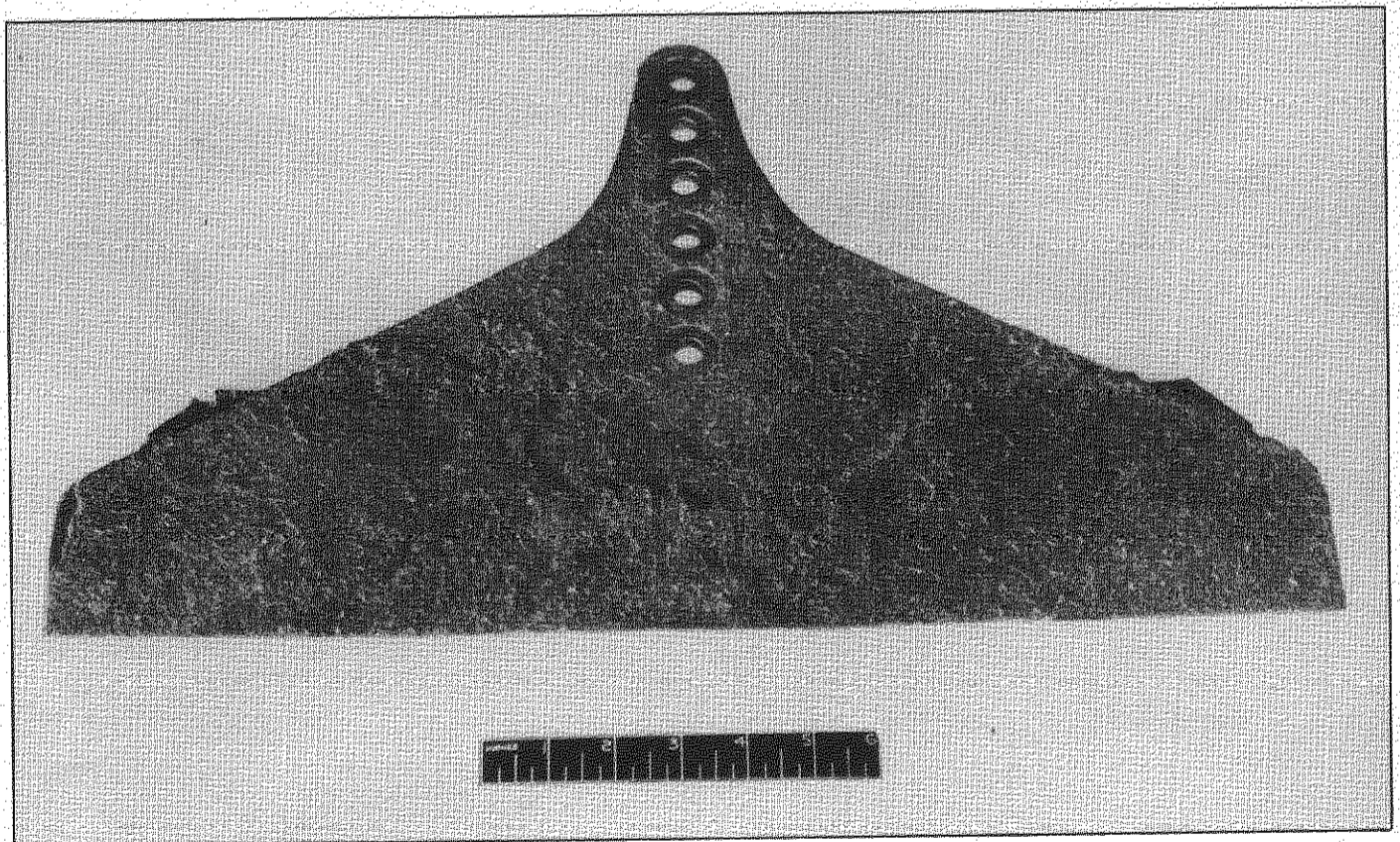

FIG.11b. GOOD VENTILATION, UNDER SURFACE

FIG.11a & b. 20 in. SPAN INSERT

FIG.12

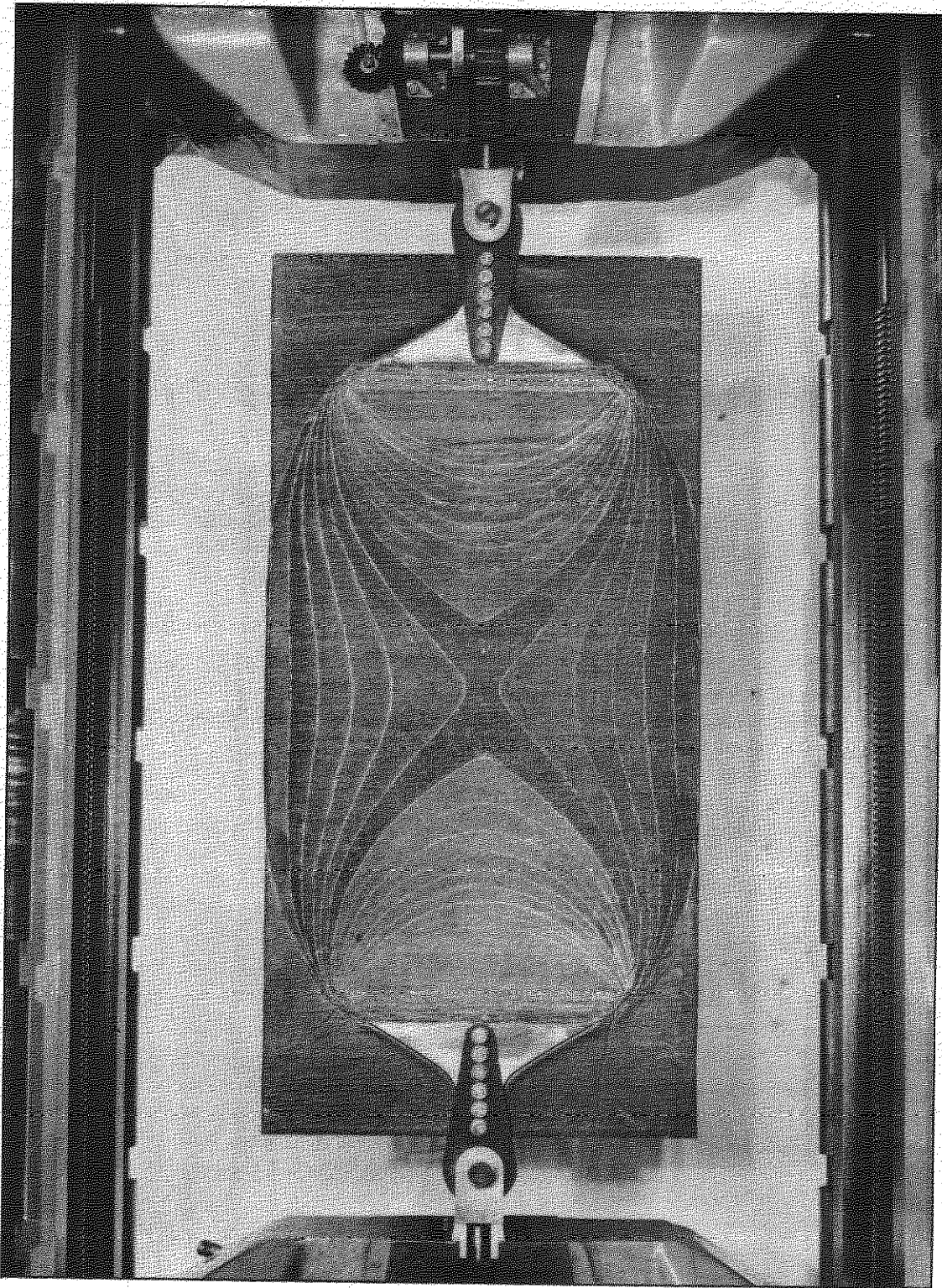

FIG.12. ASYMMETRICALLY CONTOURED TEST PANEL (PLAN VIEW)

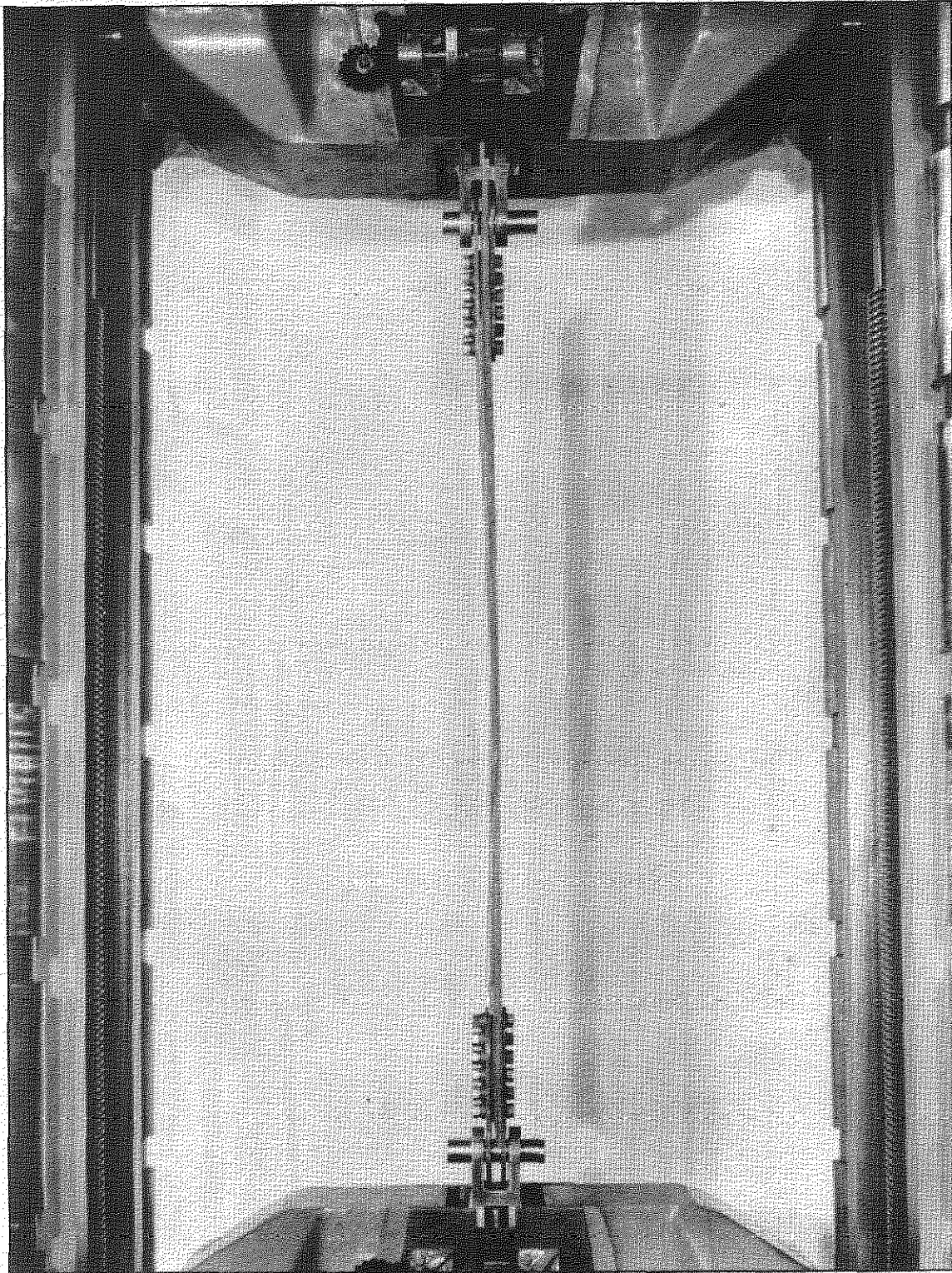

FIG.13. ASYMMETRICALLY CONTOURED TEST PANEL (SIDE VIEW)

FIG.14

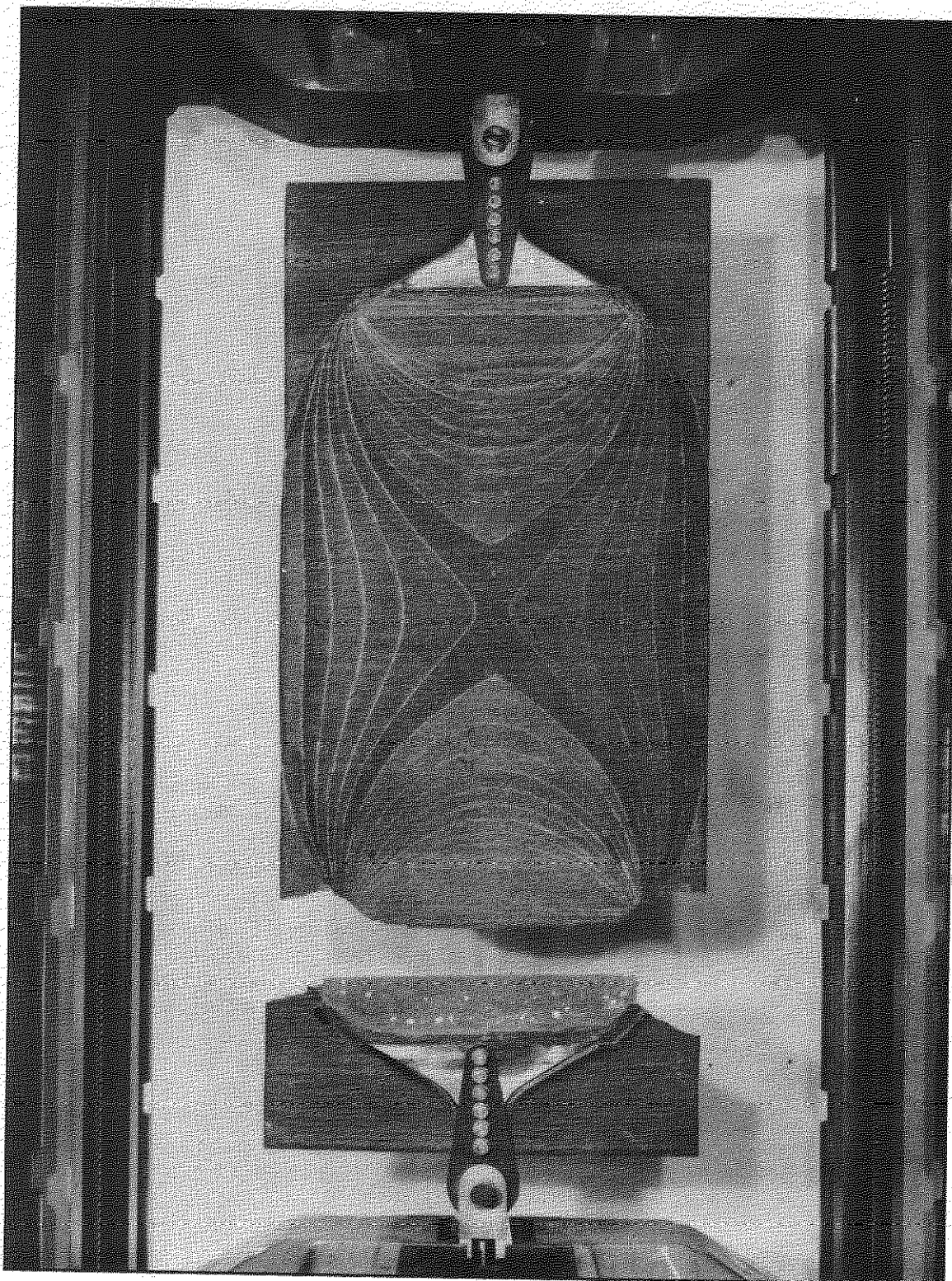

FIG.14. 20 in. INSERT TEST PANEL: FAILURE AT 52 TONS
(CONTOURED SIDE)

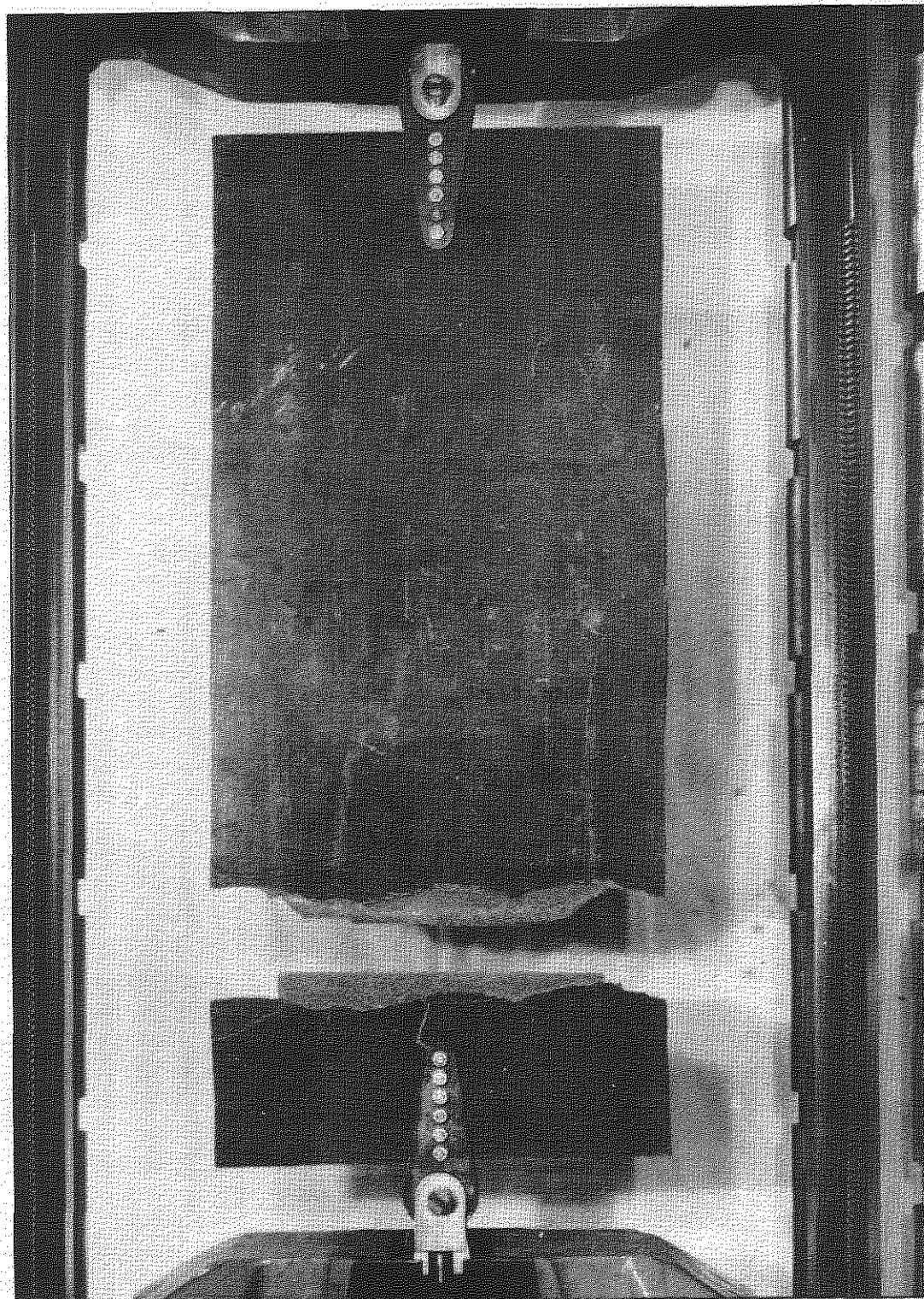

FIG.15. 20 in. INSERT TEST PANEL: SHEAR AND TENSION FAILURE, 52 TONS (PLAIN SIDE)

FIG.16

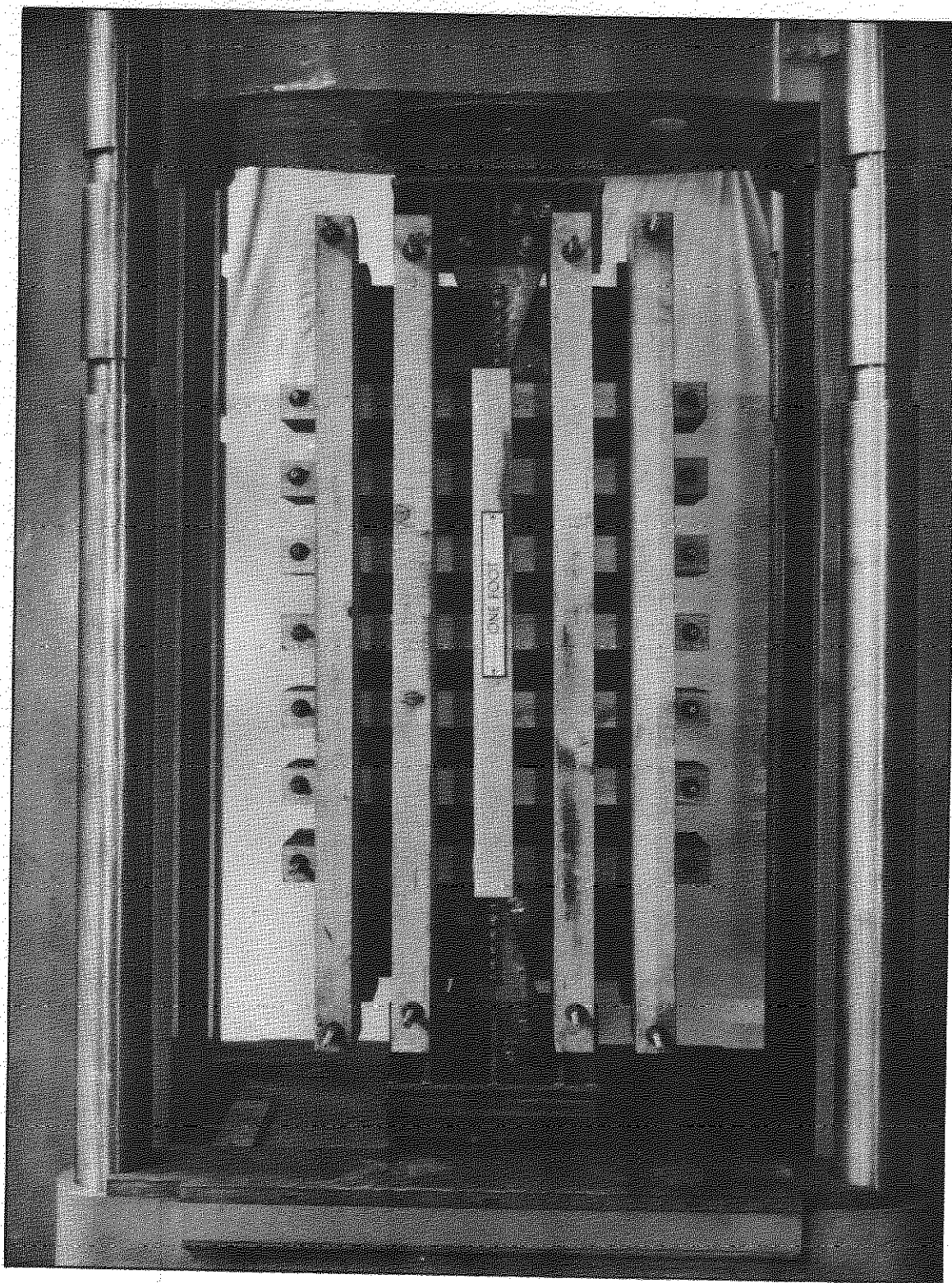

FIG.16. 20 in. INSERT COMPRESSION PANEL SHOWING
STABILISATION AND END FIXATION (PLAN VIEW)

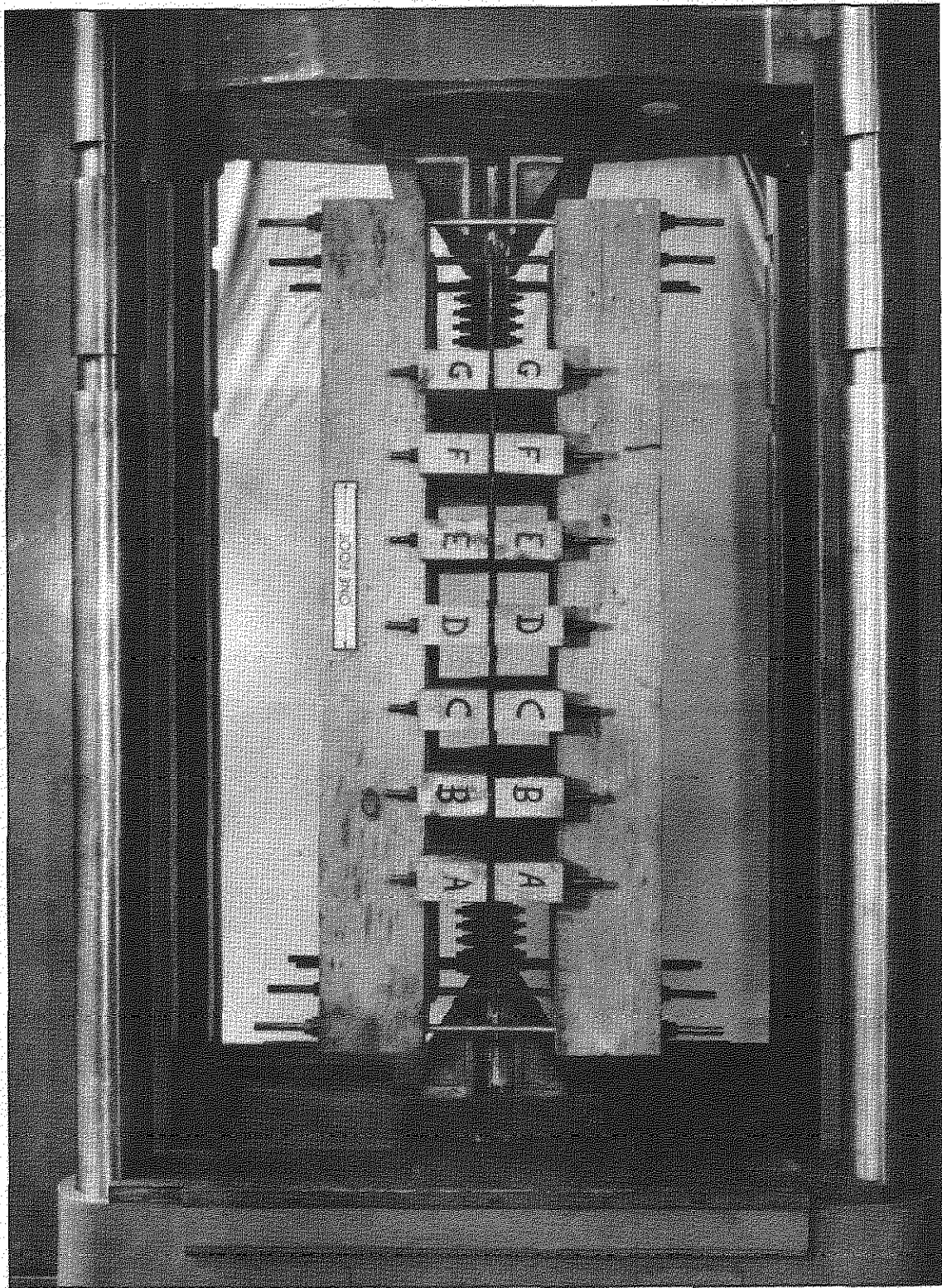

FIG.17. 20 in. INSERT COMPRESSION PANEL SHOWING STABILISATION AND END FIXATION (SIDE VIEW)

FIG.18

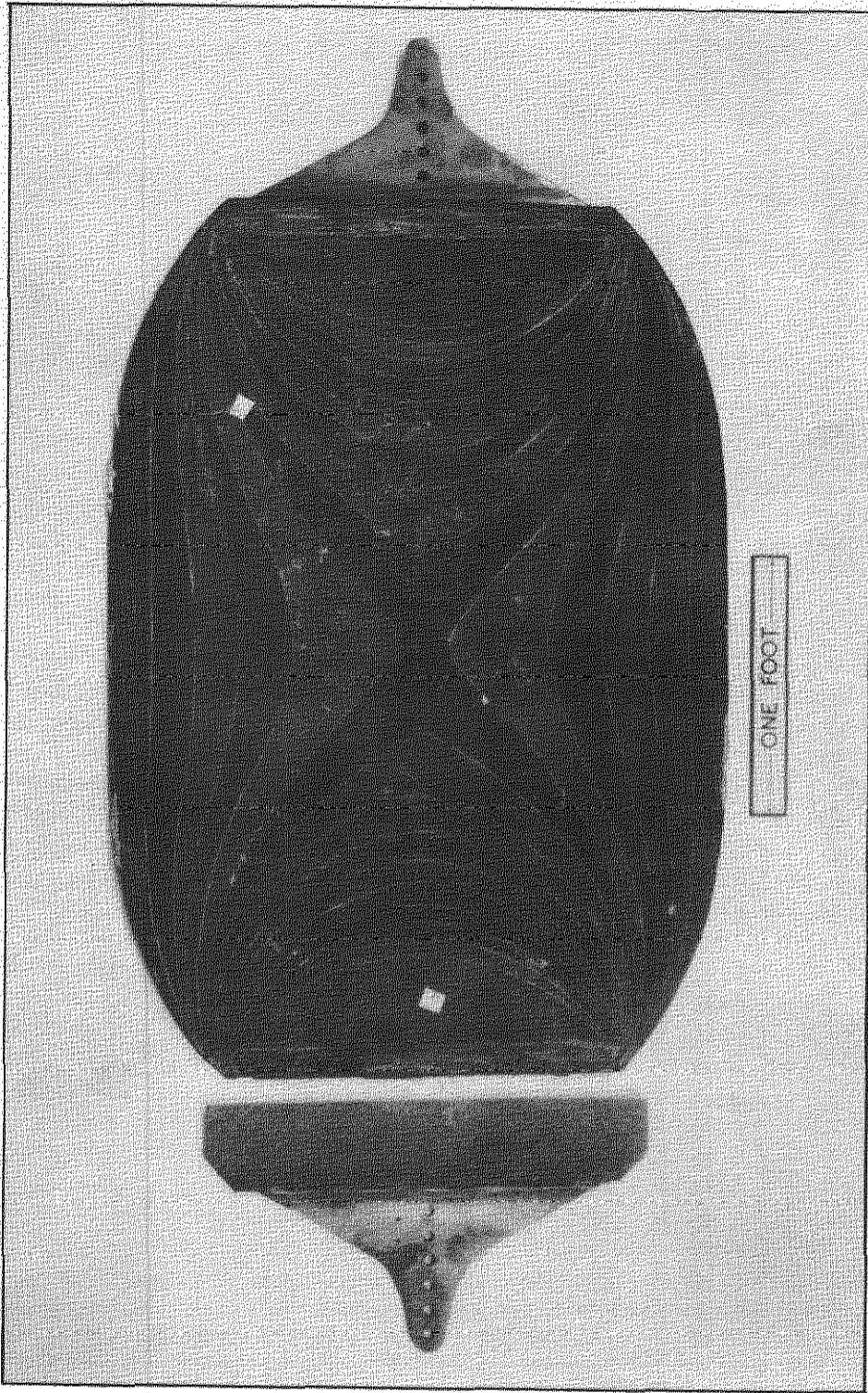

FIG.18. COMPLETELY SYMMETRICAL PANEL WITH FAILED INSERT

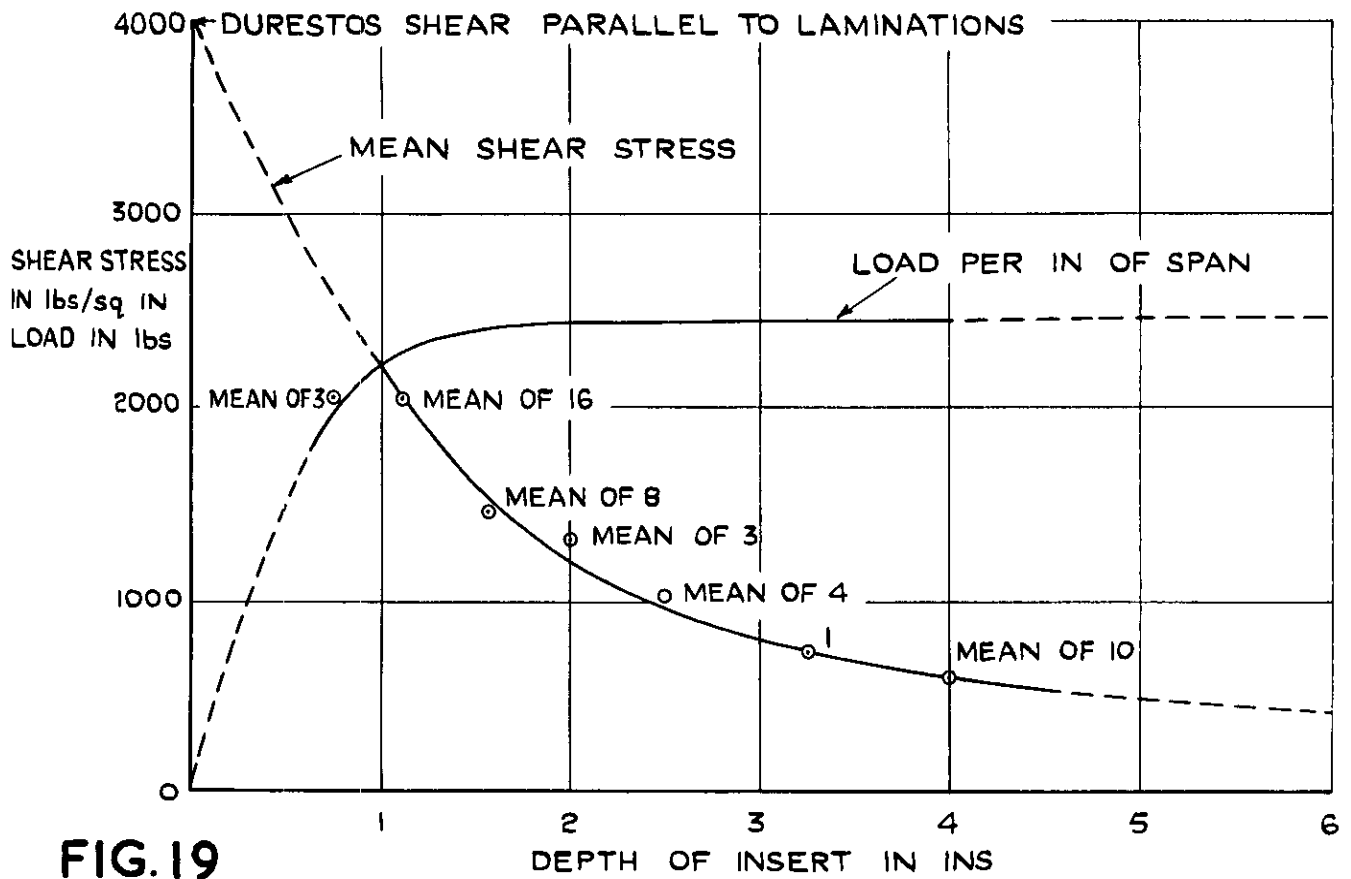

FIG.19

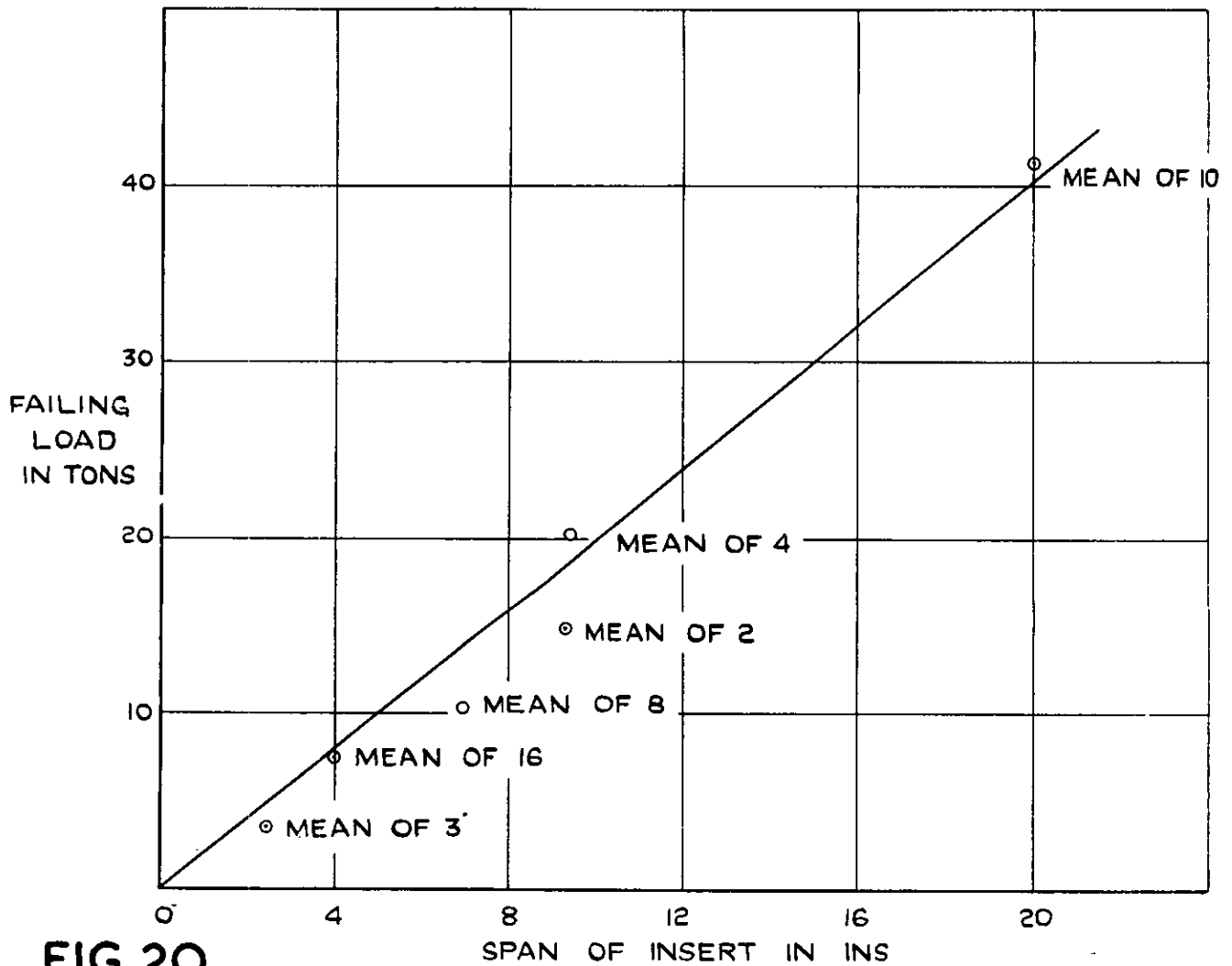

FIG.20

LOAD CHARACTERISTICS OF STEEL INSERTS IN VACUUM MOULDED DURESTOS FROM EXPERIMENTAL RESULTS.

FIG. 21, 22 & 23

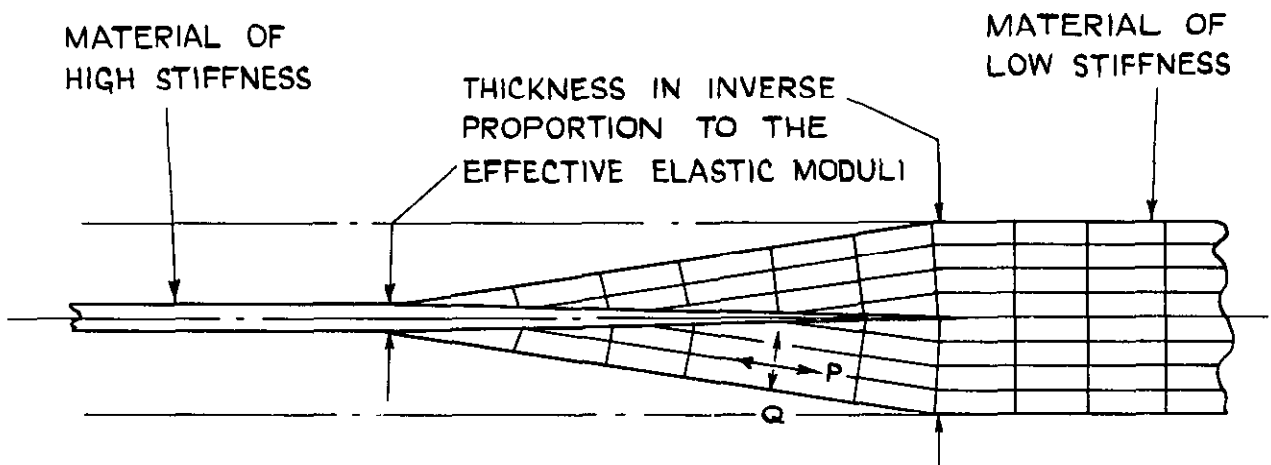

FIG. 21 DIAGRAMMATIC VIEW THROUGH THICKNESS OF AN IDEAL ADHESIVE JOINT BETWEEN TWO MATERIALS OF DIFFERENT ELASTIC MODULI. NO PLANE DIFFUSION.

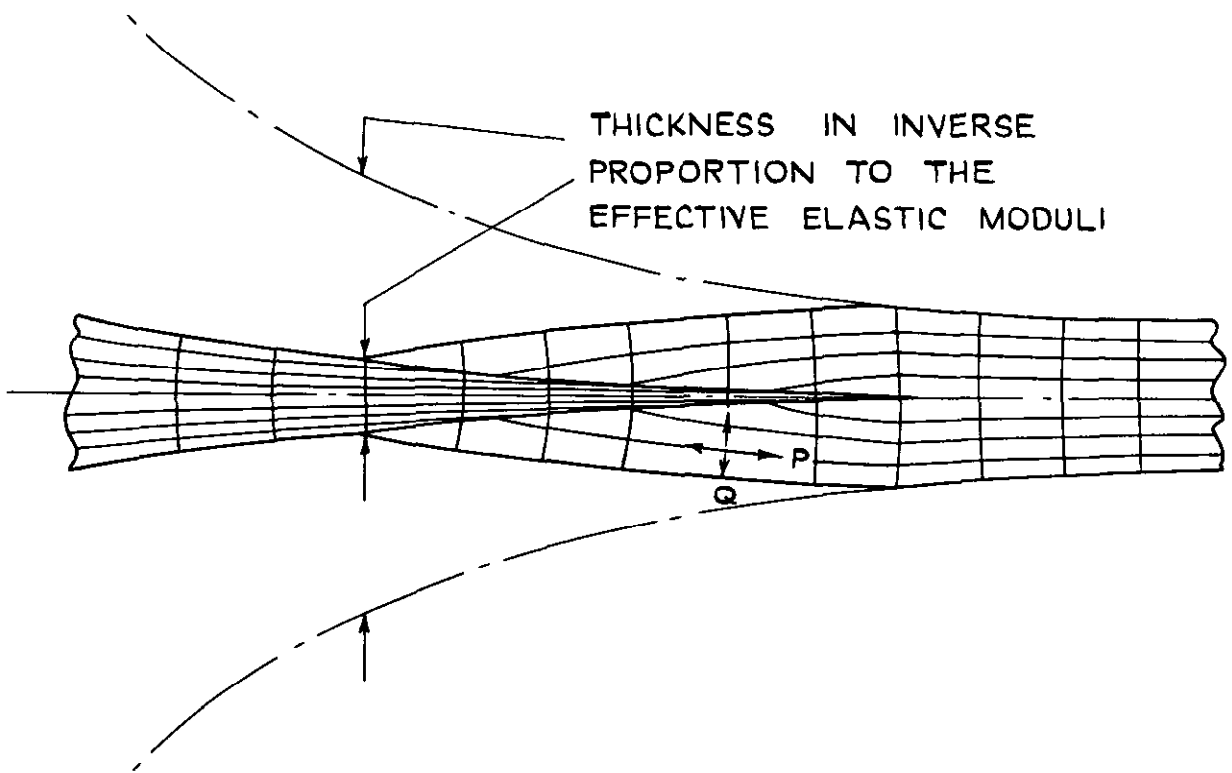

FIG. 22 SAME AS FIG. 21 BUT WITH PLANE DIFFUSION.

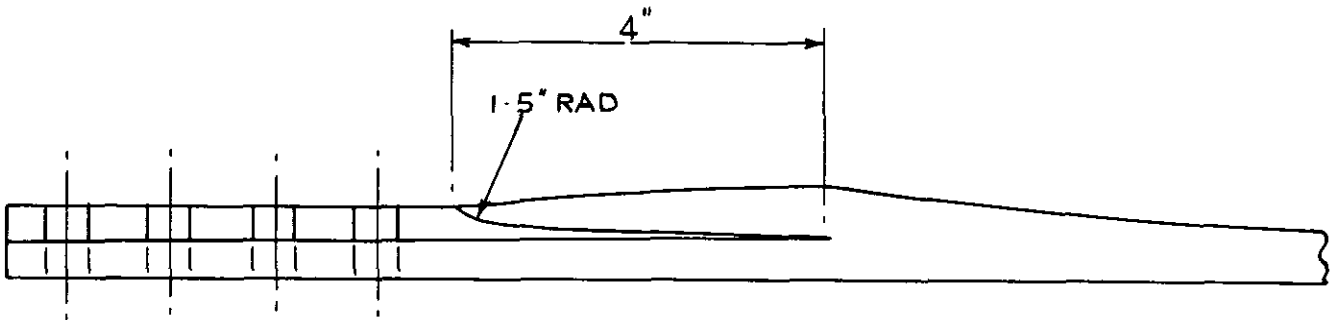

FIG. 23 TYPICAL SECTION THRO' JOINT AS USED WITH 20" SPAN INSERT TEST PANELS & DELTA PLASTIC WING.

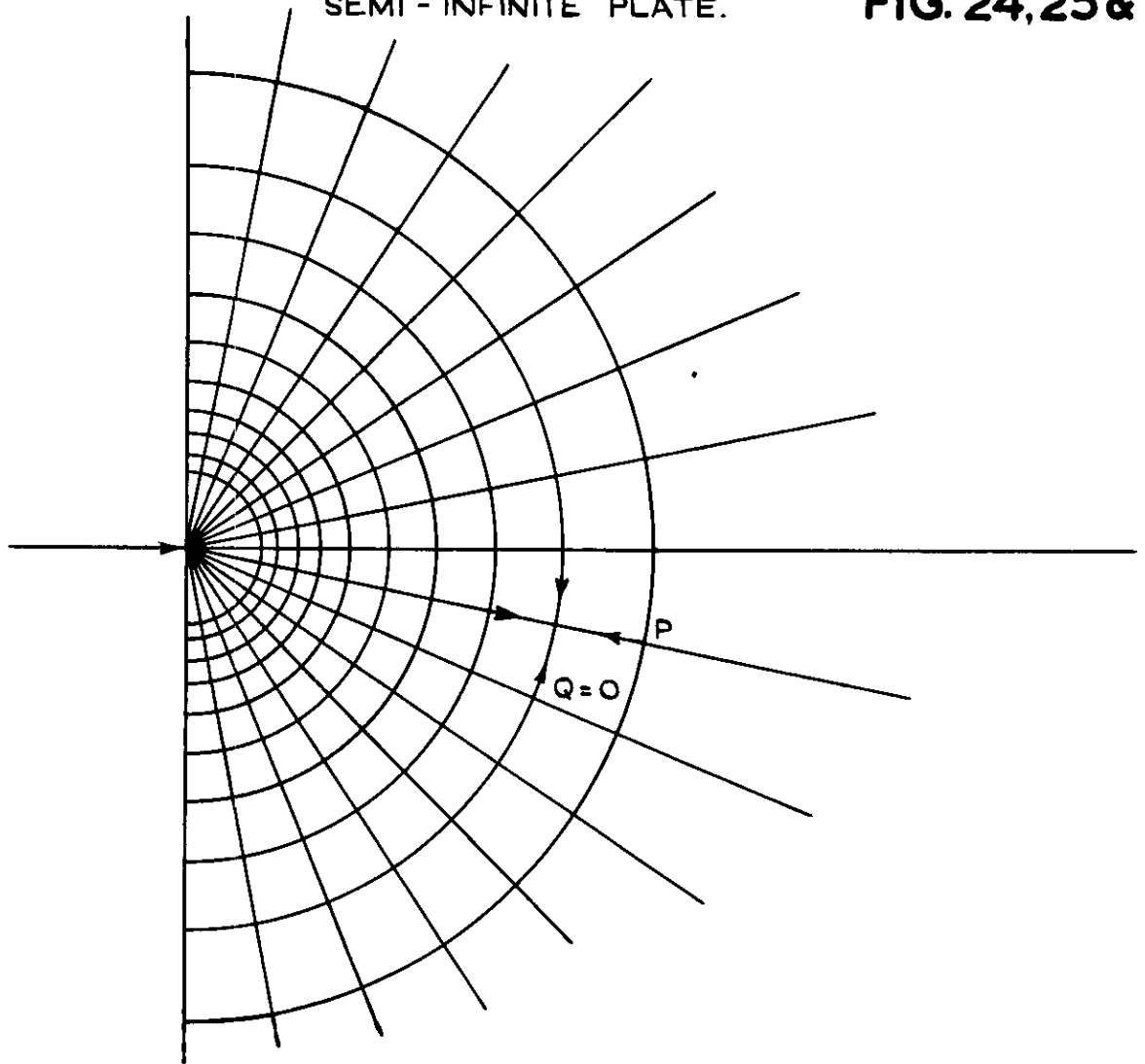

FIG. 24 PRINCIPAL STRESS TRAJECTORIES.

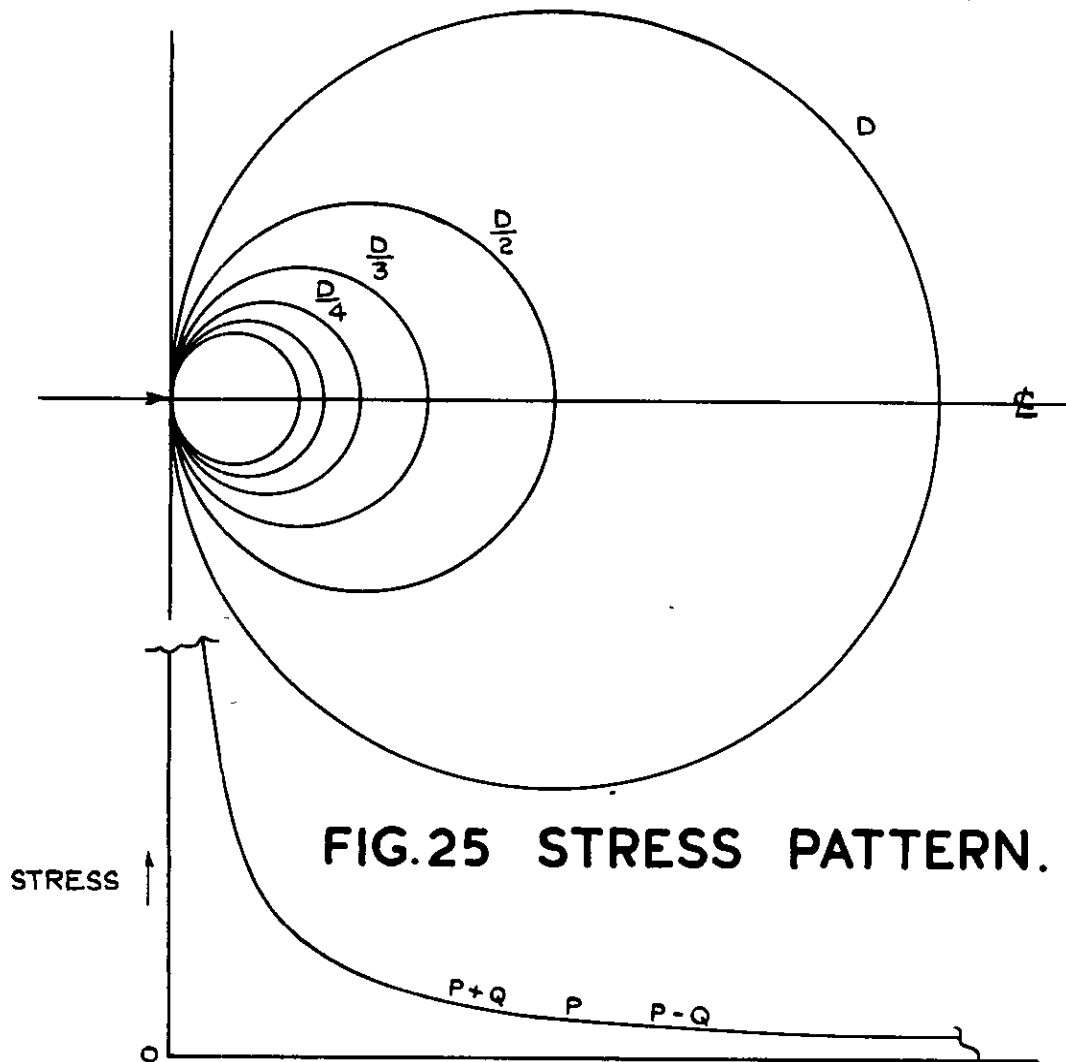

FIG. 25 STRESS PATTERN.

FIG. 26 SECTION OF STRESS PATTERN ON ϕ .

FIG. 27, 28 & 29

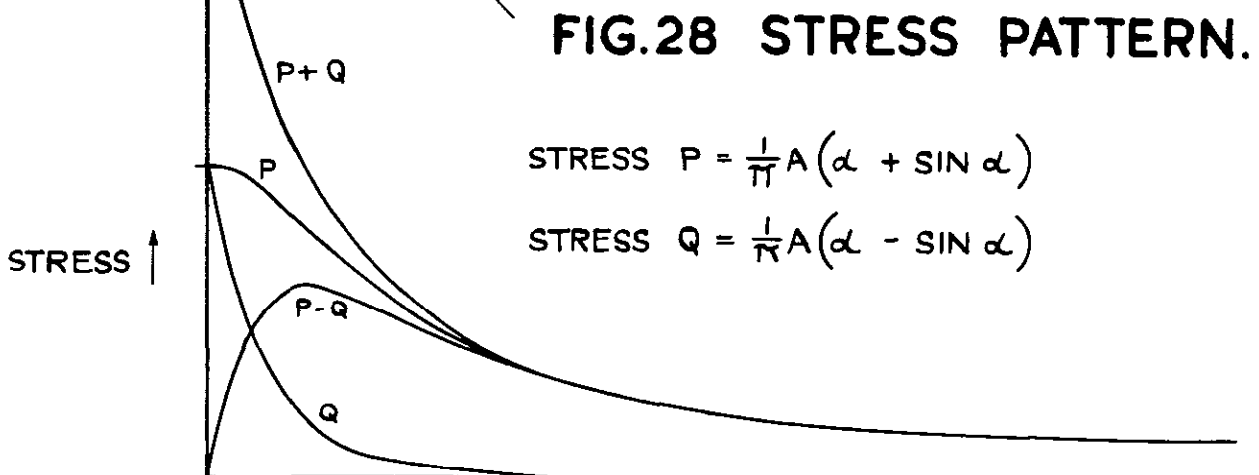
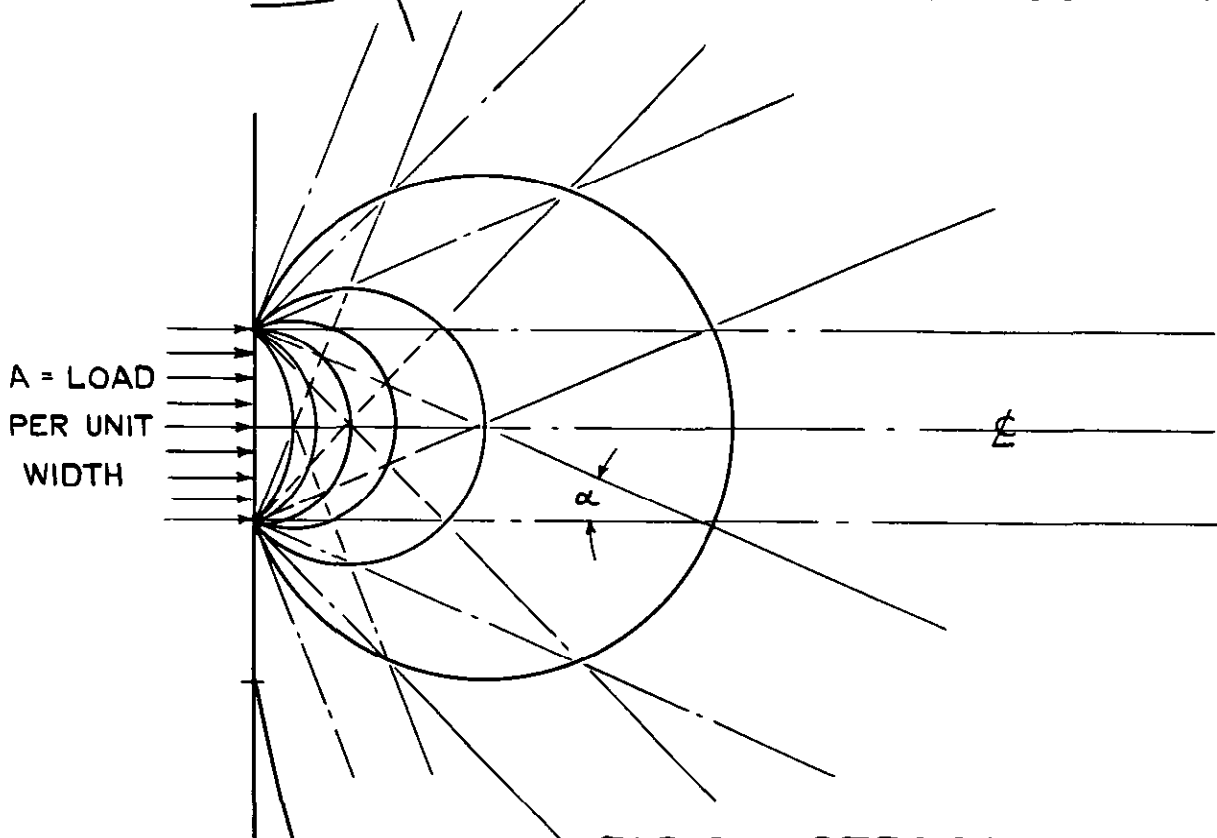
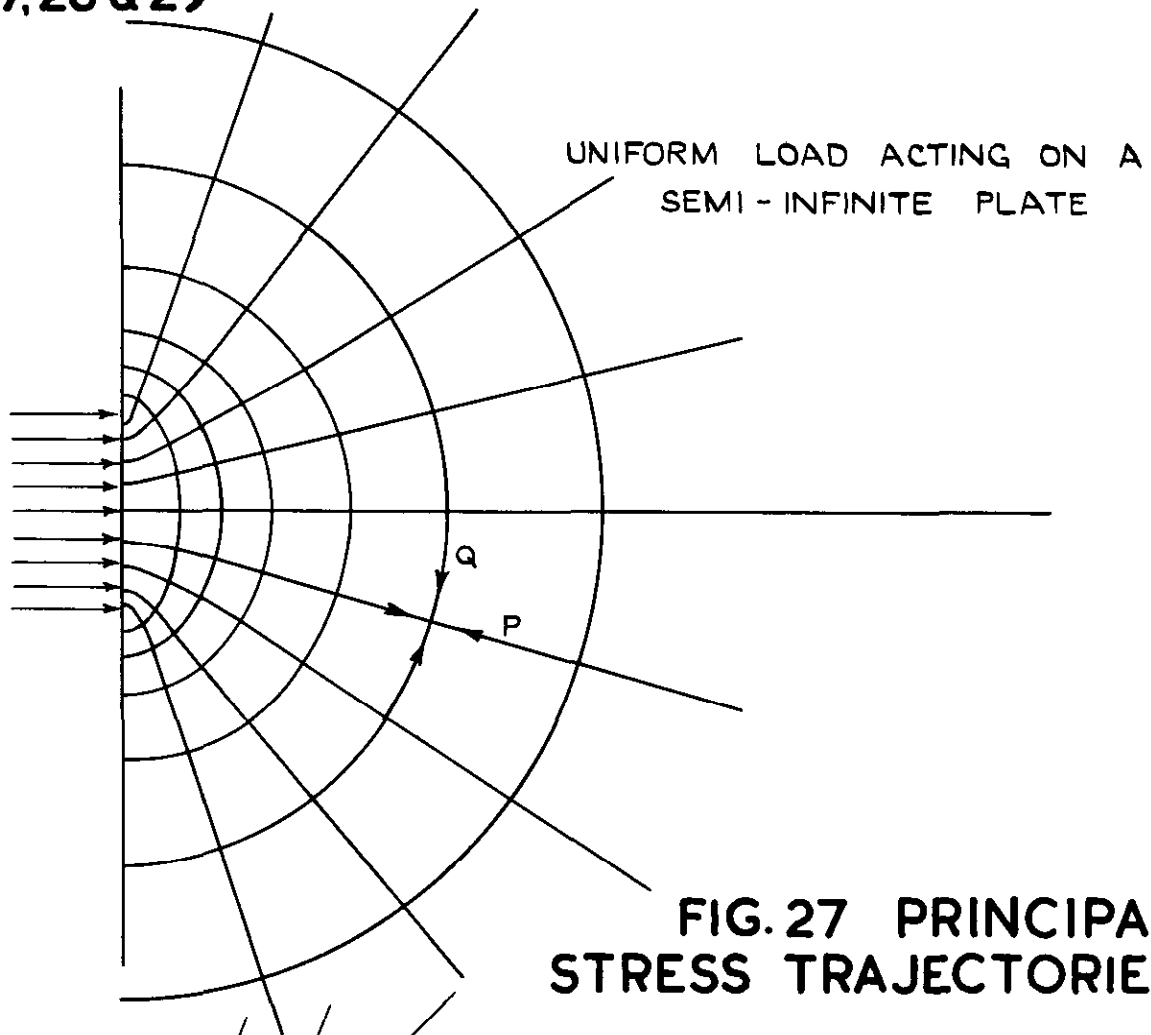

FIG. 30 STRESS
TRAJECTORIES.

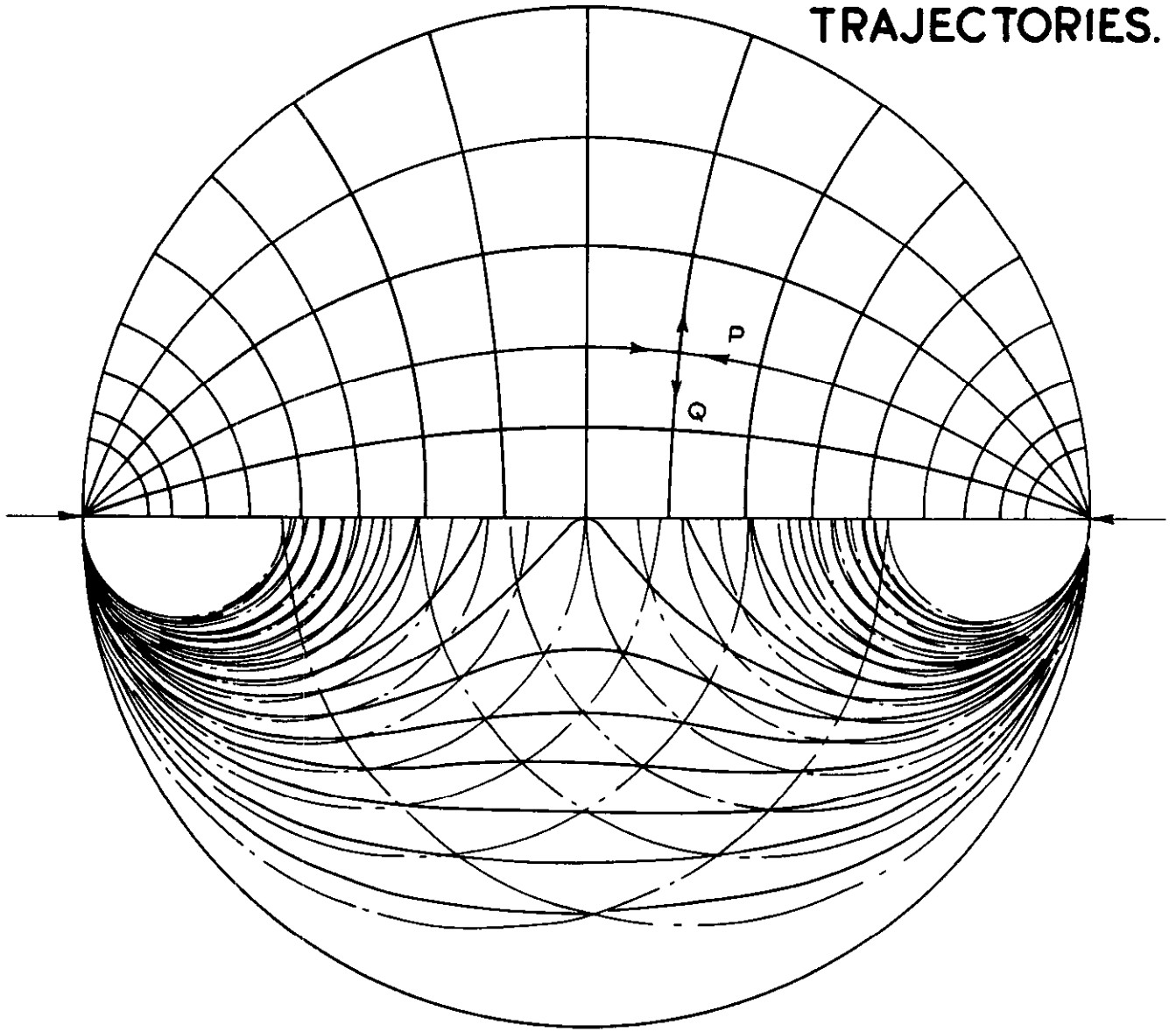

FIG.31 PRINCIPAL STRESS PATTERN.

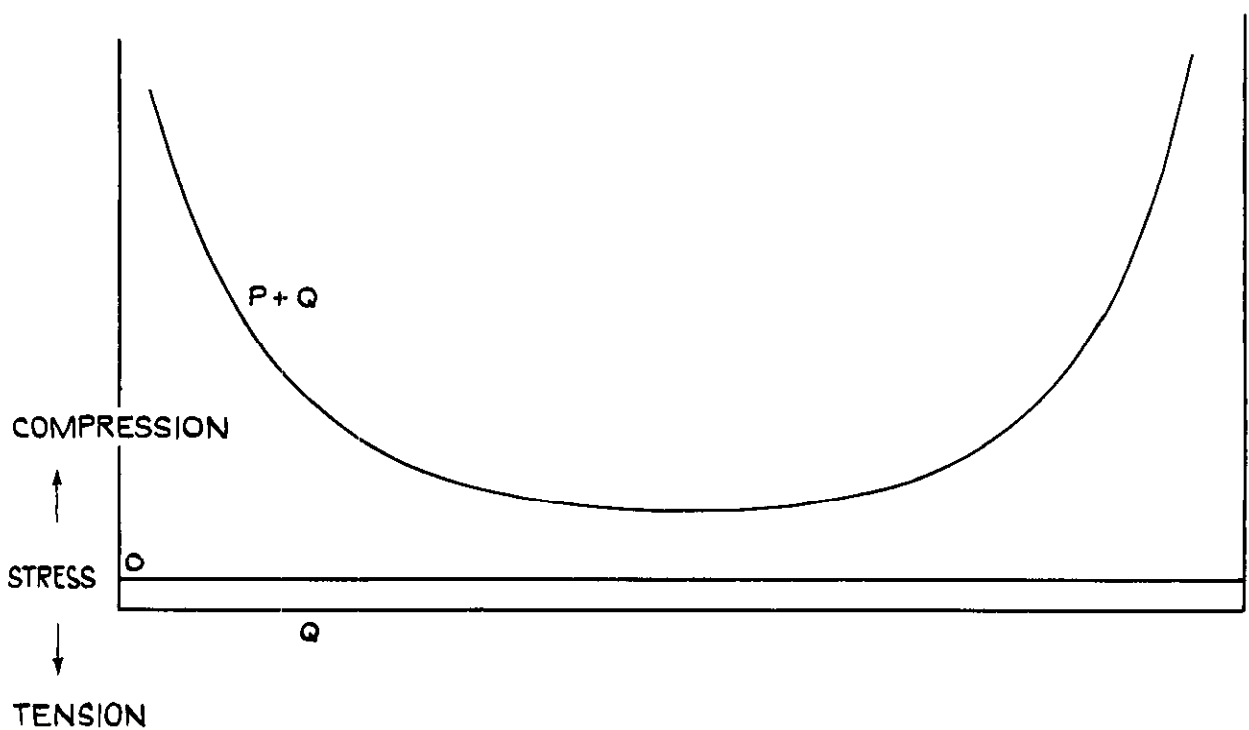

FIG. 32 SECTION OF STRESS ON ζ .

FIG. 33, 34 & 35

FIG. 33 PRINCIPAL STRESS TRAJECTORIES.

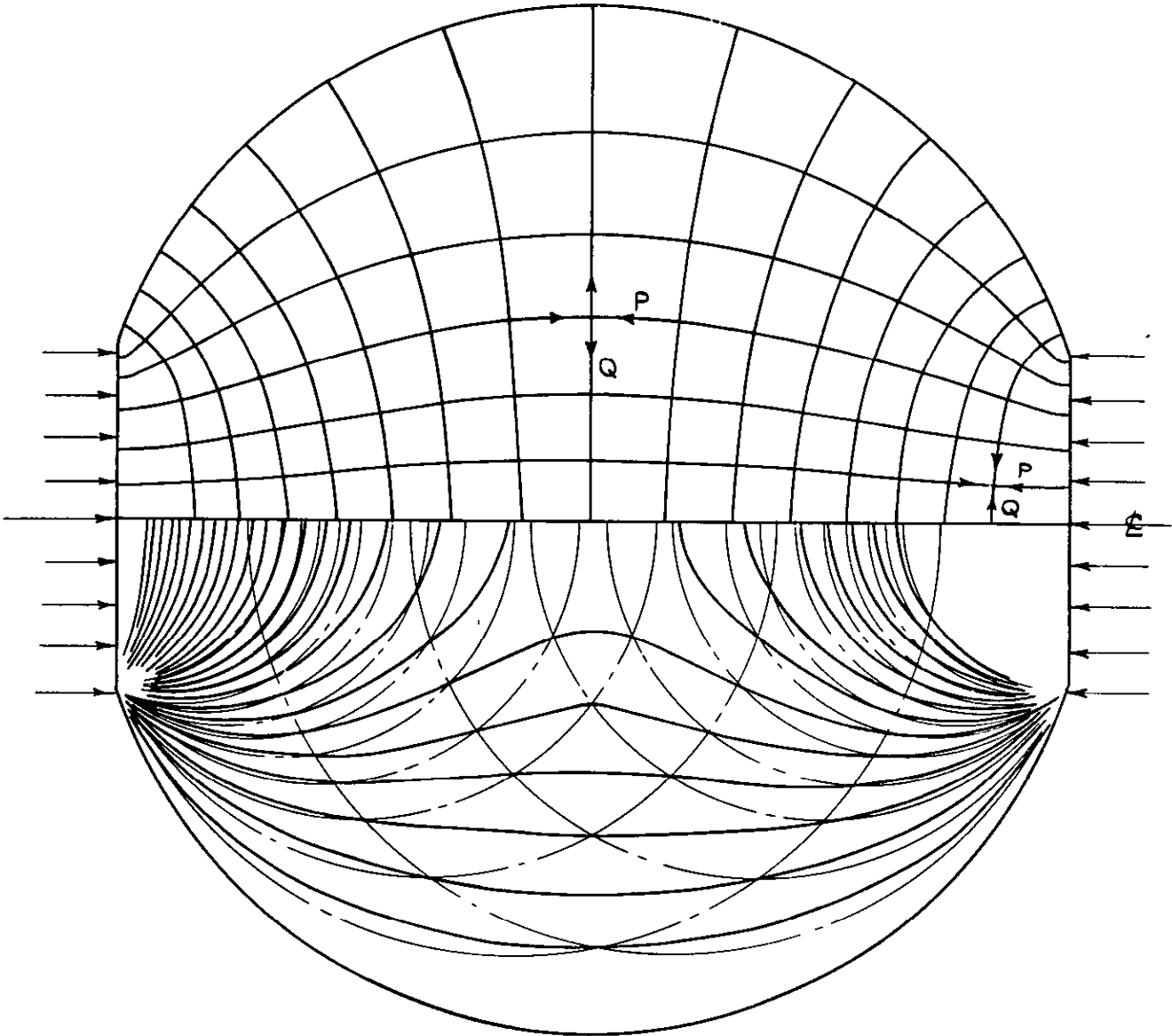

FIG. 34 STRESS PATTERN.

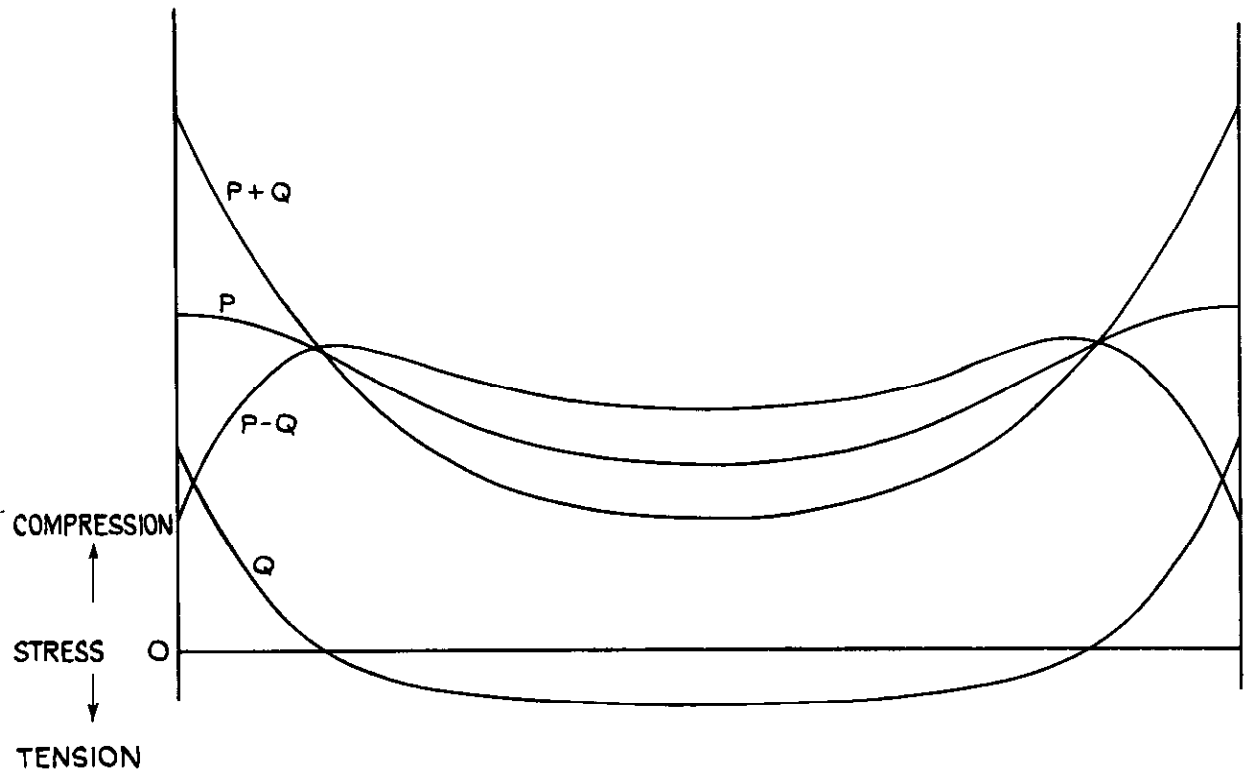

FIG. 35 SECTION OF STRESSES ON ϕ .

FIG. 36

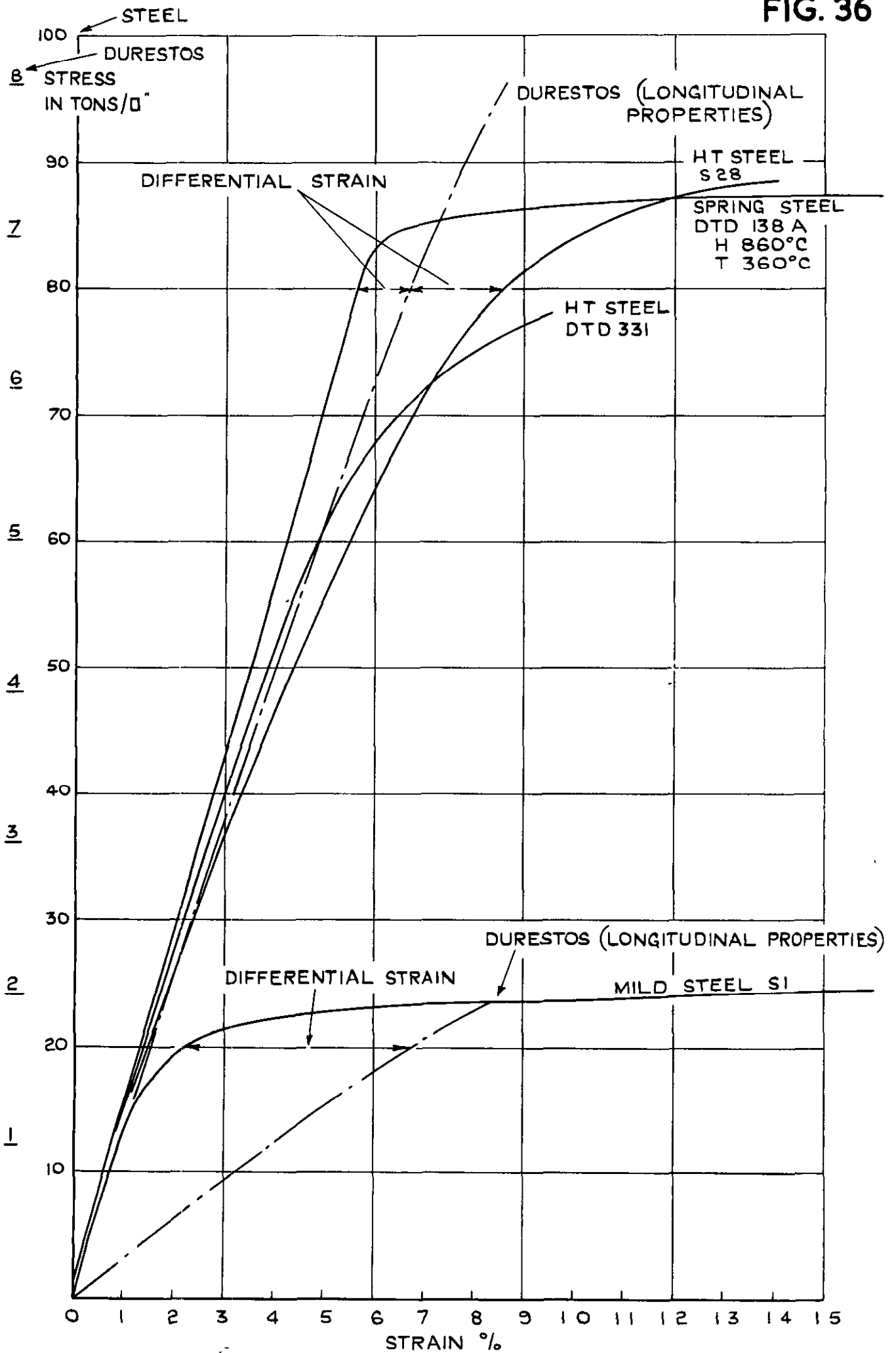

FIG.36 COMPARISON OF STRESS STRAIN CURVES OF VARIOUS STEELS WITH THAT OF DURESTOS.

FIG. 37

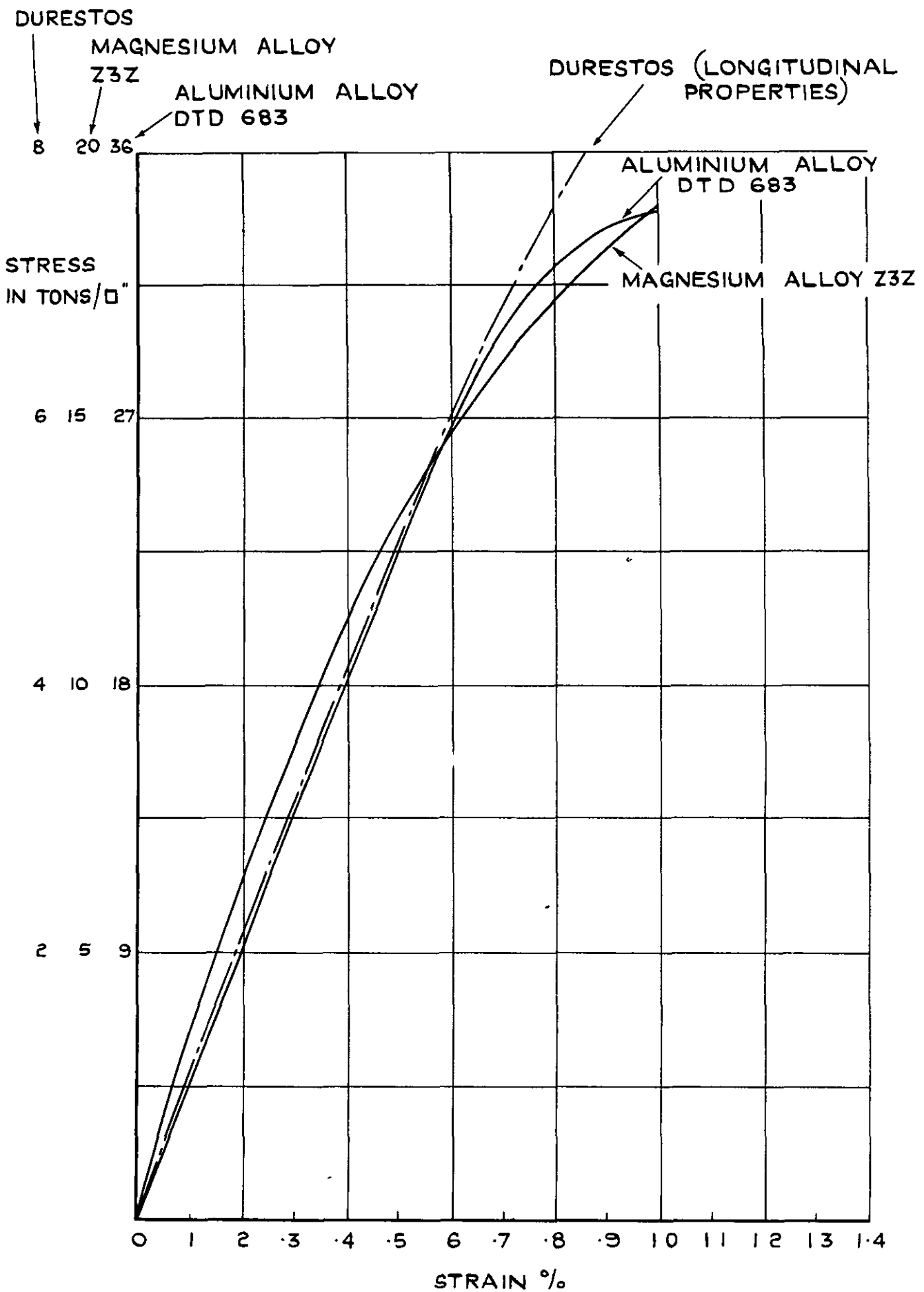

FIG.37 COMPARISON OF STRESS STRAIN CURVES OF ALUMINIUM & MAGNESIUM ALLOY WITH THAT OF DURESTOS.

FIG. 38

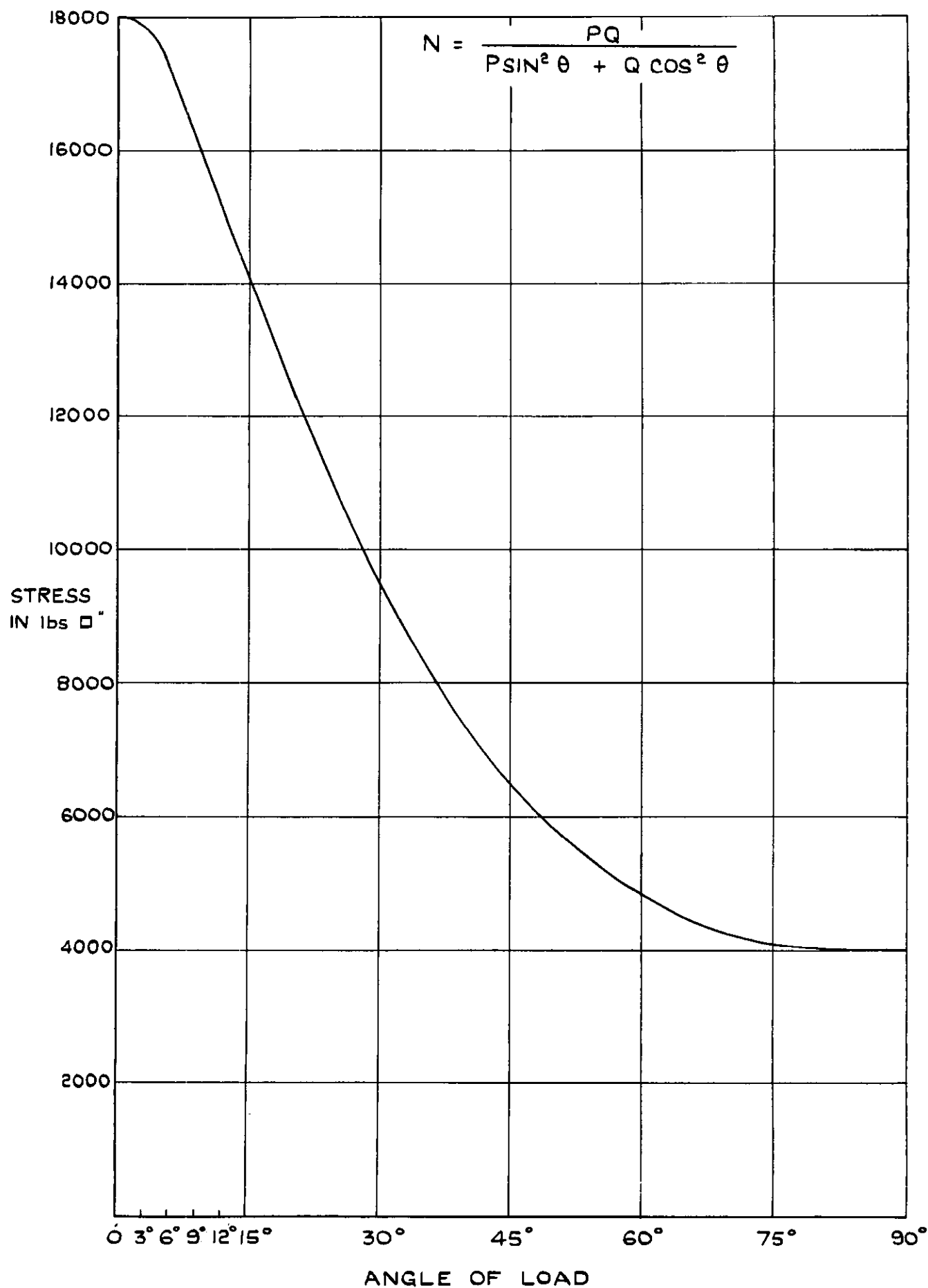

FIG.38 DURESTOS TENSION PROPERTIES THROUGH THE THICKNESS FOR ALL ANGLES OF LOADING.

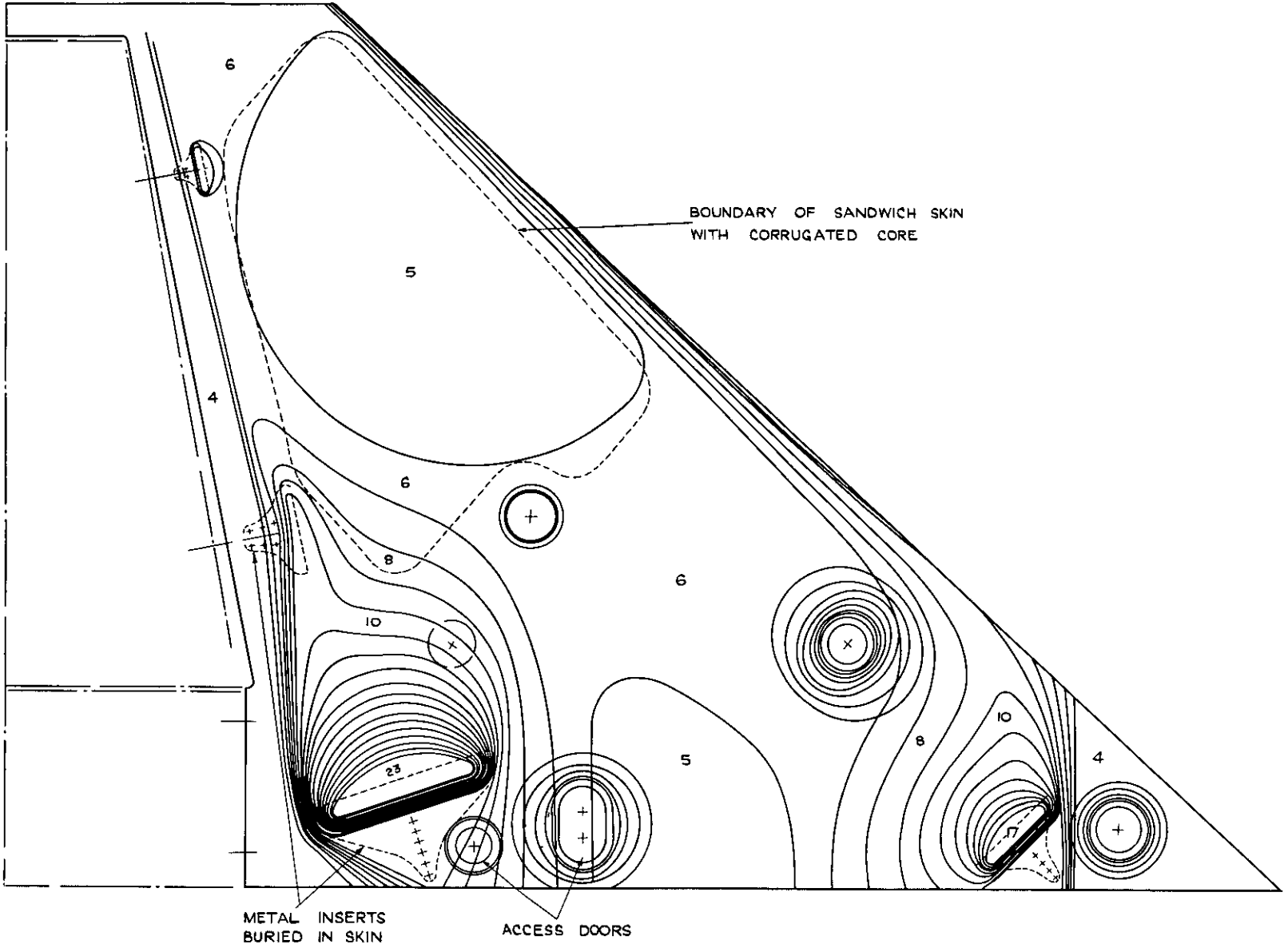

FIG 39 PLAN VIEW OF TOP SKIN OF PLASTIC DELTA WING SHOWING INSERTS AND LINES OF CONSTANT THICKNESS

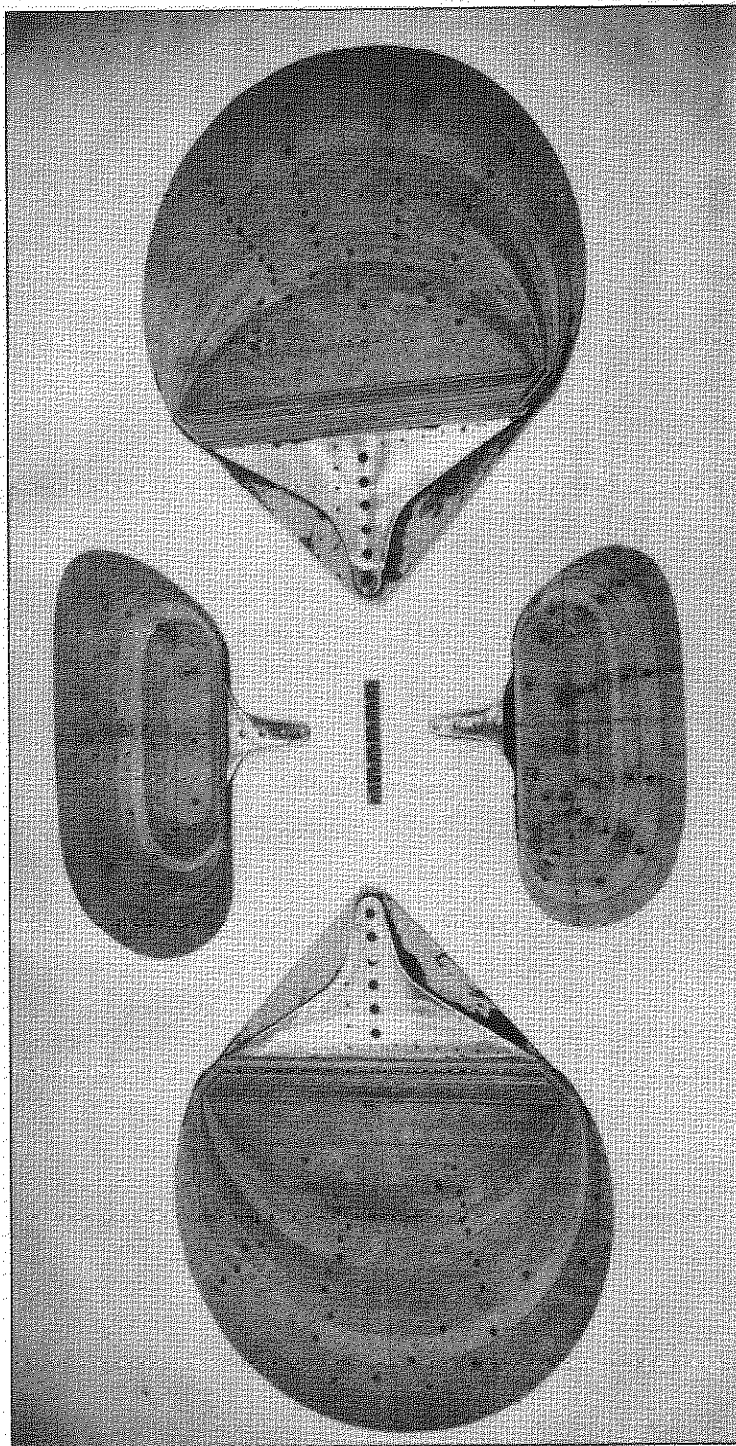

FIG.41. SUB-ASSEMBLED INSERT PACKS FOR PLASTIC DELTA WING

Crown Copyright Reserved

PUBLISHED BY HER MAJESTY'S STATIONERY OFFICE

To be purchased from

York House, Kingsway, LONDON, W C 2. 427 Oxford Street, LONDON, W 1

P O Box 569, LONDON S E 1

13a Castle Street, EDINBURGH, 2	1 St Andrew's Crescent, CARDIFF
39 King Street, MANCHESTER, 2	Towel Lane, BRISTOL, 1
2 Edmund Street, BIRMINGHAM, 3	80 Chichester Street, BELFAST

or from any Bookseller

1955

Price 8s. 6d. net

PRINTED IN GREAT BRITAIN