



PROCUREMENT EXECUTIVE, MINISTRY OF DEFENCE

AERONAUTICAL RESEARCH COUNCIL

CURRENT PAPERS

Influence of Prior Heat and Creep on
Fatigue in Structural Elements of
DTD 5014 (RR58) Aluminium Alloy

by

F. E. Kiddle

Structures Dept., R.A.E., Farnborough Hants.

RECEIVED
PROCUREMENT
1977

LONDON: HER MAJESTY'S STATIONERY OFFICE

1977

£3-00 NET

*CP No.1375

July, 1976

INFLUENCE OF PRIOR HEAT AND CREEP ON FATIGUE IN STRUCTURAL ELEMENTS OF
DTD 5014 (RR58) ALUMINIUM ALLOY

by

F. E. Kiddle

SUMMARY

Effects of heat on fatigue have been studied by fatigue tests at ambient temperature on specimens first subjected to a single period of heating with and without steady load applied. The tests employed constant amplitude loading on various structural elements in DTD 5014 (RR58) aluminium alloy material. Heating was applied at temperatures in the range 100°C to 170°C for times ranging from 1h to 20000h.

The initiation of fatigue cracks was significantly affected by heating, particularly at temperatures of 110°C and higher when the effects occurred comparatively rapidly. The two mechanisms of importance were changes in micro-structure at the machined surface which encouraged initiation, and changes in residual stress by creep which encouraged or discouraged initiation according to the creep being compressive or tensile.

of approximately 3.1. Sideplates were fitted so that the specimen could be removed from a creep machine to the fatigue machine with minimum disturbance to the seating of the pin in the lug. The pins were interconnected by two spring steel strips which were slightly longer than the pin centre distance and were bowed elastically on assembly to apply a tensile load of about 40 lb to the specimen. By this arrangement, when the specimen was not in a loading machine, the springs prevented rotation of the pins and held them in contact with the lugs in the normal loaded position. The sideplates were separated from the faces of the lug by PTFE washers. Steel shim washers were used to take up any clearance which would allow movement of the pin in a direction parallel to the bore. In fatigue testing the outer ends of the sideplates were pin jointed to end fittings.

All specimen components were thoroughly degreased with an organic solvent before assembly and all test sections were dry during testing.

3 EXPERIMENTAL PROCEDURE

The general principle of investigation was to establish a datum fatigue performance by means of continuous fatigue tests to failure at ambient temperature as described in a previous report⁴, and then to carry out comparative tests on specimens which had been first subjected to a period of heating whilst under steady tensile, zero or compressive load. The data on endurance were supplemented by fractographic and metallurgical observations on changes in the surface condition of the material and in the mode of crack initiation.

All fatigue testing was at ambient temperature in fluctuating tension ($0 < R \leq 1$) of constant amplitude applied at 33Hz. Mean stress was kept constant for each particular type of specimen and was selected to give endurances in the range 10^5 to 10^7 cycles. All stresses quoted are based on the net cross-sectional area, i.e. the region of fatigue failure.

The specimens for the programme were extracted from 63 bars of material and, to minimise uncertainties in the results arising from variation in material properties between bars and along the length of each bar, specimens were selected for test in the following way. From any bar five specimens were selected at about equal spacing along the length for fatigue testing without heating. The logarithm of endurance was plotted against position in the bar and the variation of endurance along the bar was assumed to be given by a straight line, fitted by the method of least squares - a typical example is

shown in Fig.5. This straight line defines the nominal endurance for specimens at each position in the bar. Specimens were then selected from those remaining for tests with heating; those tested at the same heating condition were widely spaced along the bar. Specimens were heated, with or without applied load, at temperatures in the range 100°C to 170°C for times from 1h to 20000h. Heating was either in a forced convection oven or, when steady load was applied, in a creep machine. When compressive load was required specimens were encased in special end fittings (see Fig.6) designed such that a tensile load on the fitting produced a compressive load on the specimen. In all cases temperatures were maintained to within $\pm 1\%$. After heating specimens were left unloaded for at least one week to ensure that specimens did not differ appreciably in the amount of creep recovery which occurred at room temperature. The specimens were then fatigue tested to failure at room temperature.

The fracture surfaces of the failed specimens were examined for two features - the number of discrete positions on the surface from which fatigue cracks emanated (damage nuclei) and the areas of the fatigue crack surfaces as illustrated in Fig.7. Observations were also made⁶ of the surface condition of the material by examining the microstructure and micro-hardness of the surface layers in the bore of holes before and after heating.

Finally, for lug specimens, the end which did not fail in the fatigue test was broken statically for examination of the fatigue crack surface and for determination of residual static strength. The results of this work are reported elsewhere⁵ and it suffices to say that heating did not significantly affect the relationship between residual static strength and crack area.

4 DISCUSSION

4.1 Effect of temperature and duration of heating period

To investigate the influence of the temperature and duration of a heating period applied prior to the fatigue test, 2.3 and 3.4 notch specimens were fatigue tested both unheated and after heating at various temperatures in the range 100°C to 170°C for times between 1h and 20000h with no load applied to the specimen. The results of the fatigue tests in terms of endurance, number of damage nuclei and fatigue crack areas are given in Tables 2 to 5 - Tables 2 and 3 give results for the 2.3 notch without heat and with heat respectively and Tables 4 and 5 give corresponding results for the 3.4 notch. These results are shown graphically in Fig.8 for the 2.3 notch and in Fig.9 for the 3.4 notch by plotting endurance against the temperature of the heating period and showing the

duration of heating in parenthesis. In these figures the ordinate is endurance expressed as a percentage of the nominal endurance in the tests without heat, as defined in section 3. For each notch it is seen that in relation to the results without heat which are plotted at 20°C, heating at 110°C and higher reduced the mean endurance by a constant amount; there is no correlation between endurance and duration of heating within the scatter bands. The lack of sensitivity of endurance to the values of exposure time and temperature above 110°C suggests that the reduction in endurance after heating represents a limiting effect which is established by quite short exposure times, although doubtless the magnitude of the reduction is particular to the type of specimen and the fatigue loading employed.

Previous work¹ showed that when heating was applied at different stages of a fatigue test, the greatest reduction in endurance was obtained when heat was applied prior to the fatigue test. The inference was that heat affected the initiation of fatigue cracks, and this is supported by the trend observed in Figs.10 and 11 for the number of damage nuclei to be increased markedly by an application of heat. To pursue the apparent connection between the reduction in endurance and the changes in the pattern of crack initiation, metallurgical and fractographic studies⁶ were conducted in the region of the specimen surface. It was found that the manufacturing process of drilling and reaming the hole left a work affected zone to a depth of about 40µm in which the hardness was significantly higher than that of the interior of the material; on unheated specimens cracks had initiated just below this hard surface film. For specimens which had been heated a number of differences were observed; the work-affected surface layer now contained a coarse secondary precipitate, its hardness was reduced to a value comparable with that of the interior, and fatigue cracks had initiated at the surface. It is deduced from this that the effect of heat was to modify the work-hardened surface layer such that its resistance to fatigue crack initiation was lowered. As a consequence the development of damage nuclei now took place right at the surface of the material and was more rapid and more uniformly distributed, causing reduction in fatigue endurance.

Returning to Figs.8 and 9, the constant reduction in endurance at temperatures above about 110°C represents the complete loss of the beneficial influence of the work-hardened surface on crack initiation. For both notches the reduction in mean endurance after heating at 100°C is considerably less than the limiting value despite the inclusion for the 3.4 notch of exposures in excess of 5000h.

This suggests that the mechanism by which heat modifies the surface layer weakens considerably as temperature is reduced from 110°C and that the limiting reduction in endurance may not be realized by heating at 100°C however long the exposure.

To summarise this section, it has been shown that exposure to heat modified the microstructure of the machined surface of a specimen, and thus increased its susceptibility to fatigue crack initiation. At temperatures of 110°C and greater the benefit of the machined surface was rapidly lost during heating and the fatigue endurance of notched specimens was reduced to a limiting value which was independent of temperature. Below 110°C the action of heat was considerably weaker.

4.2 Effect of steady load during heating

We will now consider how the effect of heat on endurance was modified by the application of steady load during the heating period. 2.3 notch specimens were heated for 3h at 150°C with various applied stresses in the range -18000 lb/in^2 to $+42800 \text{ lb/in}^2$ prior to fatigue testing to failure. Results are given in Table 6 for tests without heat and in Table 7 for tests with heat. Fig.12 shows graphically how the endurance, expressed as a percentage of nominal endurance, varies with the magnitude of the stress applied during heating and Fig.13 illustrates the corresponding variation in the number of damage nuclei. It is seen that endurance increased continuously as the stress during heating was varied through the range from compression to tension. This result suggests that load during the heating causes a significant redistribution of stress across the net section by creep, thus changing the local mean stress in the region of the notch surface during the subsequent fatigue loading. From studies of cumulative damage^{8,9} it is known that residual stress due to local yielding under the applied fatigue loads has a significant influence on the initiation and early propagation of fatigue cracks and it has been suggested^{10,11} that the modification of residual stress by creep during a heating period may therefore give a significant interaction. However, the modification of residual stress by creep will be effective only if it remains unaltered by the subsequent fatigue loading². Let us look in detail at what happens to the local stresses at the notch surfaces under typical loadings.

Fig.14a, b and c shows diagrammatically the variation of local stress at a stress concentration of 2.3 for specimens which are exposed to heat at nominal stresses for 0, +36 and -18ksi respectively and are then loaded to the

nominal mean stress of 18ksi followed by fatigue cycling at 18 ± 14 ksi. It is assumed that the material behaves perfectly elastically below its yield stress and perfectly plastically above it, that the stress-strain characteristics of the material are initially similar in tension and compression, and that the period of creep is effective in fully redistributing stress across the net section. In Fig.14a heat is applied at zero load at A and, after cooling, the specimen is loaded to a nominal peak fatigue stress of 32ksi which takes the notch stress through yield to B. Subsequent fatigue loading will alternate between B and C with a local mean stress at D. In Fig.14b the specimen is initially loaded to a nominal 36ksi which takes the notch stress past yield to E and is then heated for a period during which creep redistribution reduces the notch stress from E to F, the average stress on the net section. On unloading, the stress reduces to G with some compressive yielding and the application of a nominal peak fatigue stress of 32ksi then takes the stress to H without further yielding. Subsequent fatigue loading will now alternate between H and I with a local mean stress at J. In Fig.14c the specimen is loaded to a nominal -18ksi taking the notch stress to K. During heating compressive creep relaxes the stress to L and on unloading, the stress rises to M. Application of a nominal peak fatigue stress of 32ksi further increases the notch stress through tensile yield to N. Fatigue loading will then alternate between N and O with a local mean stress at P. It is clearly seen from Fig.14a and b that the local mean stresses under fatigue loading are significantly different, whereas a comparison of Fig.14a and c shows that the local mean stresses are the same.

Taking the 0.1% proof stress of the material given in Table 1 as the yield stress, the local mean stress under fatigue loading can be evaluated for each value of creep stress applied in the tests described earlier.

Nominal stress applied during heating period ksi	Local mean stress under fatigue loading ksi
-18	22.8
0	22.8
18	18
32	-0.2
42	-13.6

This information is presented graphically in Fig.15: local mean stress has been plotted as an inverse factor on the assumption that endurance varies approximately as the inverse of the local mean stress. It is seen that this diagram resembles the shape of the curve in Fig.12, the achieved results of creep on endurance. There are however two areas of disagreement:-

- (1) At the lower end of the curve when creep stress is in the range -18ksi to +14ksi, residual stress theory predicts no effect and the continuing trend of reducing endurance with reducing creep stress observed in Fig.12 cannot be explained. This trend has been observed generally by the author in similar work³ on other aluminium-copper alloys.
- (2) At the upper end of the endurance-creep stress curve, the rate of increase in endurance falls off at about 30ksi compared to a 43ksi level prediction by residual stress theory. This is probably due to the occurrence of creep damage which offsets the beneficial effect of creep redistribution.

A further insight into the variation of endurance with creep stress can be obtained by studying the number of damage nuclei on the fracture surfaces. Fig.13 shows that at creep stresses of -18ksi and 0 ksi, the number of damage nuclei is much higher than the mean number for cold control specimens. It has been shown by the author⁴ that an increase in the number of nuclei implies that nuclei are developing with increasing rapidity and with a corresponding shortening of the nucleation phase which contributes to the reduction in endurance. The number of nuclei for a creep stress of -18ksi suggests that the notch surface is even more susceptible to cracking than when the work-hardened layer is modified by heat at 0 ksi.

It is seen from the foregoing discussion that redistribution of stress by creep interacts significantly with fatigue and that tensile creep can give large improvements in endurance in relation to specimens subjected to heat without load.

4.3 Effect of prior heating with zero load on S-N performance

The effects of prior heating on the S-N performance of the two notched specimens and the lug specimen were established by heating specimens for 1000h at 150°C without applied load and then fatigue testing them at ambient temperature to obtain mean S-N curves for comparison with those for unheated specimens. For these tests, specimens were selected from many different bars of material and specimens from each bar were distributed over the stress range investigated.

Individual test results are given in Tables 8, 9 and 11 to 14 together with estimates of standard deviation for each test condition. Where necessary unbroken specimens were accounted for by Lariviere's method¹².

Curves of mean endurance against stress are given in Figs.16 to 18 for the three specimens tested and it is seen that heating significantly reduced endurance at all fatigue stress levels for the 2.3 notch and the 3.4 notch, but had little effect on the endurance of lug specimens. The general reduction in the S-N performance of notched specimens is in line with the findings of section 4.1 where it was shown that exposure to heat modified the microstructure of the machined surface of a specimen and thus increased its susceptibility to fatigue crack initiation. For the lug specimen, the initiation phase of the life is comparatively short⁴ due to fretting between the pin and the bore of the lug and it is not surprising therefore that heating had little effect on endurance.

Further evidence that the reduction in life is associated with a reduced initiation phase is apparent when the S-N performances for specimens with and without prior heating are compared on the basis of S-N curves drawn through the lowest endurance observed at each stress level. The significance of a curve through the lower boundary of S-N data was discussed in a previous report⁴ on the performance of the present specimens in fatigue tests without heating. It was shown that the endurance of the notched specimens tended to have an extreme value distribution resulting in a fairly definite lower limit on the endurance at each stress level. Fig.19 presents lower boundary S-N curves for the 2.3 notch showing an appreciable effect from prior heating at zero load. It is emphasized that the curve for unheated specimens passes quite smoothly through points representing the lowest values of endurance from samples ranging in size from 2 to 67 tests so it can be accepted that the curve represents an effective lower limit on endurance for tests without heating. The curve for tests with heating at zero load, for which the maximum sample size is eight tests, shows a substantial reduction in the lower limit of endurance indicating a reduction in the crack initiation phase of the life. The effect of heating on the lower limit for the 3.4 notch (see Fig.20) is smaller than for the 2.3 notch, probably because the initiation phase is shorter⁴. Fig.21 presents comparable curves for the lug specimen and it is seen that the lower limit is unaffected by heating because the initiation phase of the life is comparatively short due to fretting.

It is generally accepted that scatter is associated with the early stages of the fatigue life leading to the initiation of cracks near the surface, rather than with the later stages of the life during which the crack propagates through the cross section¹³. As heating appears to reduce the initiation phase of the life of specimens it could therefore be expected that there would be a corresponding reduction of scatter in endurance. Information on the variation of scatter in endurance with heating is presented in Figs.22 and 23 for the three specimens tested. Fig.22 is a striking demonstration of reduction in scatter for the 2.3 notch, but surprisingly no significant effect is observed for the 3.4 notch in Fig.23. For the lug specimen, also in Fig.23, again there is no significant effect but this would be expected as heating has no effect on the mean or lower limit S-N performance.

4.4 Effect of prior heating with steady load on S-N performance

In section 4.2 it was shown that the application of steady load during heating caused creep redistribution at the stress concentration and modified the endurance in relation to that obtained after heating without load. We will now consider the effect of applying a tensile stress during heating on the S-N performance of the 2.3 notch.

The prior heating exposure was 1000h at 150°C with an applied stress equal to the subsequent fatigue mean stress (18000 lb/in²); on average the overall creep strains measured were 0.014%. The results of these tests are given in Table 10 and are plotted as a mean S-N curve in Fig.16 which shows that prior creep had a beneficial effect on endurance by comparison with the effect of prior heat; increase in life ranged from a factor of 1.25 at high alternating stresses to a factor of 15 at a low alternating stress (8000 lb/in²). Although the longer lives after creep were a consequence of the reduced local mean stress, the specimens without the benefit of creep redistribution also experienced a reduction in local mean stress when the peak stress of the fatigue loading caused local yielding. Thus with increasing alternating stress the benefit of creep diminished and was superseded by the effect of yielding where the two curves converge.

The diminishing benefit from creep with increasing alternating stress is re-presented in Fig.24 as the ratio of the endurances after creep and after heat, and is seen to have an approximately linear relationship with alternating stress. Consideration of the stress-strain behaviour at the root of the notch,

as already demonstrated in Fig.14, shows that the local mean stress in the heated specimens reduces linearly with increasing alternating stress. It follows that the linear fall off in creep benefit in Fig.24 would be expected if there was an approximately inverse linear relationship between log endurance and mean stress.

Prior creep is seen to affect also the lower limit of endurance for the 2.3 notch in Fig.19. The significant increase in the lower limit over most of the stress range is indicative of a lengthened initiation phase, compatible with the increase in mean life already discussed. The increase in scatter from prior creep in Fig.22 is also as expected.

5 CONCLUSIONS

Fatigue tests under constant amplitude loading were conducted on simple structural specimens in DTD 5014 (RR58) aluminium alloy material, and the effect of applying heat, with or without a steady load, prior to the tests was determined. The following conclusions were drawn:

- (a) Heating caused microstructural changes in the machined surface of the material which increased its susceptibility to fatigue crack initiation. The result was a significant reduction in the fatigue endurance of notched specimens, but for lug specimens the reduction was comparatively small because the influence of the machined surface on crack initiation was short lived under the action of fretting.
- (b) Heating at temperatures of 110°C and greater reduced the fatigue endurance rapidly with time of exposure, to a limiting value which was independent of temperature. Below 110°C the action of heat was considerably weaker.
- (c) Steady load during heating caused stress redistribution by creep. The resulting change in local stress in the region of crack initiation was beneficial or detrimental to fatigue performance according to the creep being tensile or compressive.

Table 1(a) Chemical composition

Element	% by weight
Cu	2.33
Mg	1.64
Si	0.15
Fe	1.07
Mn	0.08
Zn	0.09
Ni	1.28
Ti	0.03
Al	Remainder

Material was solution treated for 8 hours at 530°C
and artificially aged for 17 hours at 200°C

(b) Static tensile properties

No. of specimens tested	Mean 0.1% PS lb/in ²	Estimated standard deviation of 0.1% PS	Mean UTS lb/in ²	Estimated standard deviation of UTS
84	55350	1160	62830	827

Table 2

FATIGUE TESTS WITHOUT HEAT - NOTCH $K_t = 2.3$ FATIGUE STRESS - $18000 \pm 14000 \text{ lb/in}^2$ - CONTROL SPECIMENS FOR PRIOR HEAT TESTS

Specimen No.	Nominal endurance 10^5 cycles	Achieved endurance 10^5 cycles	Achieved endurance % nominal	Major fatigue crack		Minor fatigue crack	
				Area % net section	Number of damage nuclei*	Area % net section	Number of damage nuclei*
12301	0.683	0.705	103	35	1c	8	2c
12305	0.688	0.728	106	50	1c + 2	23	3
12310	0.694	0.600	87	41	2c	0	0
12315	0.700	0.694	99	65	2c + 1	1	1c
12319	0.705	0.754	107	52	1c	17	2c
13701	0.690	0.701	102	43	1c	11	2c
13705	0.673	0.676	100	35	2c	6	2c
13710	0.654	0.671	103	42	1c	22	2c
13715	0.634	0.549	87	36	2c	1	2c
13719	0.619	0.683	110	59	2c	47	2c + 1
14301	0.799	0.720	90	39	1c + 3	22	2
14305	0.737	0.817	111	45	2c	25	2c
14310	0.665	0.809	122	43	2c	9	2c
14315	0.601	0.427	71	41	1c + 2	4	2c + 3
14319	0.554	0.640	116	42	1c + 4	2	1c + 1
14601	0.626	0.651	104	37	2c	8	1c
14605	0.641	0.503	79	48	2c	14	1c + 4
14609	0.656	0.823	126	38	2c	0	0
14615	0.680	0.751	110	45	2c	14	1c
14619	0.696	0.614	88	32	2c	3	1c
15101	0.587	0.621	106	74	2c	2	1c
15105	0.590	0.619	105	38	1c	3	1c
15110	0.594	0.491	83	58	1c + 1	1	1c
15115	0.598	0.604	101	42	1c	1	1c
15119	0.602	0.650	108	44	1c	1	1c
19201	0.685	0.733	107	20	1c + 1	1	2
19205	0.652	0.594	91	22	1c + 1	3	2
19210	0.613	0.639	104	26	1c + 2	24	1c
19215	0.576	0.534	93	23	1c + 4	17	1c + 2
19219	0.548	0.580	106	22	2c + 8	12	8

* For example, 2c + 3 means that there were five nuclei, one at each corner of the hole and three along the bore.

Table 3

FATIGUE TESTS WITH PRIOR HEAT - NOTCH $K_t = 2.3$ FATIGUE STRESS = $18000 \pm 14000 \text{ lb/in}^2$

Specimen No	Temperature of heating period °C	Duration of heating period h	Nominal endurance 10^5 cycles	Achieved endurance 10^5 cycles	Achieved endurance % nominal	Major fatigue crack		Minor fatigue crack	
						Area % net section	Number of damage nuclei*	Area % net section	Number of damage nuclei*
14309	100	3	0.679	0.743	109	46	2c	9	1c
14317	"	"	0.577	0.752	130	49	2c + 1	25	2c
14617	"	"	0.688	0.708	103	59	2c + 3	11	1c + 1
14306	110	"	0.722	0.689	95	59	2c + 1	11	1c
14312	"	"	0.639	0.560	88	48	2c	8	2c
14608	"	"	0.652	0.639	98	41	1c	33	2c
13702	"	1406	0.686	0.470	69	49	1c + 1	3	2c + 3
13704	"	"	0.678	0.362	53	48	1c + 16	28	1c + 13
13717	"	"	0.627	0.434	69	58	2c + 4	16	1c + 5
14308	120	3	0.693	0.807	117	59	1c + 3	36	2
14314	"	"	0.613	0.601	98	51	2c + 3	42	2c + 4
14614	"	"	0.675	0.600	89	34	2c	20	1c
13706	"	371	0.669	0.476	71	50	1c + 4	34	1c + 3
13707	"	"	0.665	0.520	78	60	2c + 6	43	2c + 4
13712	"	"	0.646	0.543	84	42	1c + 3	24	1c + 7
14316	130	3	0.589	0.467	79	42	2c + 2	37	1c + 3
14613	"	"	0.626	0.441	70	56	2c + 5	8	2c + 4
14618	"	"	0.692	0.621	90	40	2c + 1	31	2c
13709	"	105	0.658	0.568	86	64	1c + 5	22	1c + 1
13718	"	105	0.623	0.455	73	53	1c + 8	33	1c + 6
14318	140	3	0.565	0.624	110	46	2c + 2	19	1c
14606	"	"	0.644	0.607	94	40	2c	7	1c + 1
14611	"	"	0.664	0.695	105	42	2c + 2	30	1c
13708	"	31.5	0.661	0.492	74	56	1c + 6	27	2c + 4
13714	"	31.5	0.638	0.548	86	54	2c + 5	49	1c + 5
12307	150	3	0.691	0.499	72	62	1c + 7	36	2c + 6
12312	"	"	0.697	0.523	75	72	1c + 8	44	2c + 9
14303	"	"	0.767	0.455	59	59	1c + 6	30	2c + 6
14311	"	"	0.752	0.619	82	50	2c + 2	39	2c + 3
14603	"	"	0.633	0.758	120	43	2c + 5	32	1c + 3
15107	"	"	0.592	0.277	47	50	1c + 7	45	1c + 17
15112	"	"	0.596	0.474	80	56	1c + 4	34	1c + 3
13703	"	10	0.682	0.550	81	40	1c + 1	37	1c + 7
13711	"	10	0.650	0.547	84	55	1c + 6	9	1c + 5
19203	"	1000	0.668	0.572	86	35	12	19	1c + 9
19211	"	1000	0.605	0.508	84	25	2c + 18	14	12
14604	160	3	0.637	0.469	74	54	2c + 2	27	4
14612	160	"	0.668	0.613	92	64	2c + 4	55	1c + 3
14602	170	"	0.629	0.575	91	51	2c + 6	35	2c + 3
14607	"	"	0.648	0.517	80	47	2	14	2c + 2
14613	"	"	0.671	0.629	94	56	2c + 5	8	2c + 4

* For example, 2c + 3 means that there were five nuclei, one at each corner of the hole and three along the bore.

Table 4

FATIGUE TESTS WITHOUT HEAT - NOTCH $K_t = 3.4$ FATIGUE STRESS - $18000 \pm 8000 \text{ lb/in}^2$ - CONTROL SPECIMENS FOR PRIOR HEAT TESTS

Specimen No.	Nominal endurance 10^5 cycles	Achieved endurance 10^5 cycles	Achieved endurance % nominal	Major fatigue crack		Minor fatigue crack	
				Area % net section	Number of damage nuclei*	Area % net section	Number of damage nuclei*
10201	0.823	0.945	115	63	1c + 5	5	1c + 10
10205	0.858	0.782	91	52	1c + 4	37	5
10210	0.903	0.735	81	55	4	31	2
10215	0.951	1.12	118	59	6	25	1c + 10
10219	0.991	0.987	100	61	1c + 4	25	1c + 3
11301	1.30	1.22	93	54	2c + 3	38	2c + 6
11305	1.27	1.27	100	71	2c + 3	24	1c + 9
11310	1.24	1.36	110	48	2c + 6	39	2c + 10
11315	1.20	1.34	112	70	2c + 3	2	1c + 5
11319	1.17	1.03	88	43	1c	37	2c + 2
13301	1.36	1.18	86	62	4	41	1c + 7
13305	1.29	1.35	105	46	1c + 3	5	1c + 3
13310	1.20	1.46	122	39	2	9	1
13315	1.12	1.19	106	40	1c + 2	30	2c + 4
13319	1.06	0.911	86	49	1c + 5	5	2c + 6
15001	1.47	1.74	119	41	2	21	1c
15005	1.34	1.17	87	44	1c + 1	19	1c + 5
15011	1.17	1.01	86	49	1c + 2	32	1
15015	1.07	1.06	99	55	2c + 2	2	8
15018	1.00	1.14	114	33	2c	27	1c + 2
15901	1.10	1.12	102	43	1c	36	2c
15905	1.09	1.08	99	59	2c	21	1c
15910	1.09	1.06	98	45	1c	31	1c
15915	1.08	1.08	100	75	2c + 3	6	1c + 1
15919	1.08	1.10	102	42	1c	9	2
16501	0.838	0.760	91	54	19	21	16
16505	0.889	1.09	122	42	1	25	1c + 5
16510	0.957	0.849	89	63	12	30	1c + 9
16515	1.03	1.03	100	61	2c + 8	54	12
16519	1.09	1.11	102	60	2c + 9	1	1c + 2
16901	0.855	0.935	109	36	1c + 9	30	1c + 6
16905	0.867	0.904	104	61	1c + 4	33	1c + 3
16910	0.882	0.773	88	46	5	16	1c + 15
16915	0.897	0.695	78	59	10	44	1c + 8
16919	0.910	1.18	129	73	2c + 7	16	9
17201	1.20	1.24	103	61	2c + 6	49	2c + 5
17205	1.20	1.07	89	43	2c	31	1c + 1
17210	1.20	1.46	121	63	1c + 2	2	10
17215	1.20	1.03	86	43	3	30	2
17219	1.21	1.27	105	40	1c	39	1c

* For example, 2c + 3 means that there were five nuclei, one at each corner of the hole and three along the bore.

FATIGUE TESTS WITH PRIOR HEAT - NOTCH $K_t = 3.4$ FATIGUE STRESS - $18000 \pm 8000 \text{ lb/in}^2$

Specimen No.	Temperature of heating period °C	Duration of heating period h	Nominal endurance 10^5 cycles	Achieved endurance 10^5 cycles	Achieved endurance % nominal	Major fatigue crack		Minor fatigue crack	
						Area % net section	Number of damage nuclei*	Area % net section	Number of damage nuclei*
10206	100	54.5	0.866	0.748	86	47	4	40	1c + 5
11314	"	"	1.21	0.782	65	73	2c + 12	22	2c + 13
15907	"	"	1.09	0.990	91	51	2c + 1	28	1c
17206	"	"	1.20	1.04	87	39	1c + 1	29	1c
17212	"	"	1.20	0.822	68	56	1c + 4	52	2c + 5
10211	"	545	0.912	0.720	79	64	1c + 8	56	1c + 11
11307	"	"	1.26	0.865	69	66	1c + 10	44	2c + 8
11318	"	"	1.18	0.771	65	58	1c + 6	29	1c + 6
15912	"	"	1.09	0.753	69	73	1c + 6	33	1c + 7
17202	"	"	1.20	0.791	66	45	1c + 7	34	2c + 1
10213	"	5450	0.931	1.02	109	56	7	34	4
10218	"	"	0.981	0.825	84	45	3	45	3
11312	"	"	1.22	1.18	97	63	1c + 7	61	6
15909	"	"	1.09	1.04	95	75	1c + 8	21	2c + 5
17216	"	"	1.20	1.14	95	63	1c + 8	57	1c + 8
10208	110	13.5	0.885	0.504	57	52	1c + 5	37	7
11304	"	"	1.28	0.918	72	49	1c + 5	25	2c + 7
15914	"	"	1.09	0.811	75	55	2c + 4	9	1c + 2
17217	"	"	1.21	0.819	68	48	1c + 6	42	1c + 5
10217	"	134	0.971	0.665	69	61	9	44	1c + 8
11313	"	"	1.22	0.690	57	52	2c + 13	48	7
15903	"	"	1.10	0.647	59	59	2c + 9	20	2c + 4
15918	"	"	1.08	0.588	54	61	2c + 11	57	2c + 8
17209	"	"	1.20	0.737	61	53	2c + 9	43	1c + 8
10203	"	1340	0.840	0.646	77	54	1c + 9	42	7
10214	"	"	0.922	0.666	72	48	1c + 8	41	1c + 7
11308	"	"	1.25	0.931	74	60	1c + 8	53	2c + 9
15913	"	"	1.09	0.594	55	61	12	59	13
17211	"	"	1.20	0.658	55	49	9	45	9
10204	120	3.5	0.849	0.685	81	63	1c + 8	18	1c + 8
11317	"	"	1.19	0.943	80	53	1c + 4	42	2c + 3
15908	"	"	1.09	0.710	65	51	1c + 11	50	2c + 9
17203	"	"	1.20	0.906	75	45	2c + 3	26	2c + 3
10209	"	35.5	0.894	0.699	78	58	2c + 7	55	2c + 5
11306	"	"	1.27	0.707	56	52	2c + 6	38	1c + 8
15916	"	"	1.08	0.642	59	46	6	44	1c + 4
17207	"	"	1.20	0.887	74	54	6	44	1c + 6
10216	"	354	0.961	0.683	71	53	8	39	1c + 8
11311	"	"	1.23	0.742	60	53	10	47	7
15904	"	"	1.09	0.634	58	66	1c + 11	50	1c + 8
17218	"	"	1.21	0.650	54	64	1c + 13	62	18
16503	"	20000	0.863	0.640	74	60	1c + 14	31	10
16511	"	20000	0.972	0.678	70	47	6	32	1c + 6
10207	130	1	0.875	0.859	98	75	1c + 7	38	1c + 7
11303	"	"	1.29	1.05	81	53	1c + 2	51	2c + 3
15917	"	"	1.08	0.815	75	54	1c + 5	36	1c + 2
17208	"	"	1.20	0.965	80	53	1c + 3	45	1c + 4
10214	"	10	0.941	0.588	63	72	2c + 10	49	1c + 8
11316	"	"	1.19	0.688	58	65	1c + 10	39	1c + 5
15902	"	"	1.10	0.580	53	55	8	54	10
17204	"	"	1.20	0.601	50	43	1c + 5	42	1c + 4
10202	"	100	0.831	0.594	72	44	1c + 5	39	8
11309	"	"	1.24	0.902	73	52	2c + 3	42	2c + 4
15911	"	"	1.09	0.641	59	58	1c + 9	45	1c + 8
17214	"	"	1.20	0.679	56	66	1c + 9	63	1c + 11
13307	150	1000	1.25	0.810	65	55	18	46	11
15003	"	"	1.41	0.819	58	51	10	37	6
15013	"	"	1.12	0.857	77	36	6	35	11
16918	"	"	0.907	0.613	68	55	4	29	1c + 6

* For example, 2c + 3 means that there were five nuclei, one at each corner of the hole and three along the bore.

Table 6

FATIGUE TESTS WITHOUT HEAT - NOTCH $K_t = 2.3$
 FATIGUE STRESS - $18000 \pm 14000 \text{ lb/in}^2$ - CONTROL SPECIMENS FOR PRIOR CREEP TESTS

Specimen No.	Nominal endurance 10^5 cycles	Achieved endurance 10^5 cycles	Achieved endurance % nominal	Major fatigue crack		Minor fatigue crack	
				Area % net section	Number of damage nuclei*	Area % net section	Number of damage nuclei*
12301	0.683	0.705	103	35	1c	8	2c
12305	0.688	0.728	106	50	1c + 2	23	3
12310	0.694	0.600	87	41	2c	0	0
12315	0.700	0.694	99	65	2c + 1	1	1c
12319	0.705	0.754	107	52	1c	17	2c
15101	0.587	0.621	106	74	2c	2	1c
15105	0.590	0.619	105	38	1c	3	1c
15110	0.594	0.491	83	58	1c + 1	1	1c
15115	0.598	0.604	101	42	1c	1	1c
15119	0.602	0.650	108	44	1c	1	1c
19001	0.691	0.644	93	57	1c + 2	1	1
19005	0.676	0.734	109	56	1c + 1	12	1c + 1
19010	0.658	0.613	93	60	3	13	1c + 1
19015	0.640	0.770	120	40	1	9	1c
19019	0.627	0.552	88	65	1c + 4	32	2c + 3

* For example, 2c + 3 means that there were five nuclei, one at each corner of the hole and three along the bore.

Table 7

FATIGUE TESTS WITH PRIOR CREEP - NOTCH $K_t = 2.3$
 FATIGUE STRESS - 18000 ± 14000 lb/in² - HEATING PERIOD = 3 HOURS AT 150°C

Specimen No.	Applied creep stress lb/in ²	Nominal endurance 10 ⁵ cycles	Achieved endurance 10 ⁵ cycles	Achieved endurance % nominal	Major fatigue crack		Minor fatigue crack	
					Area % net section	Number of damage nuclei*	Area % net section	Number of damage nuclei*
12304	-18000	0.687	0.305	44	61	11	52	11
12317	"	0.703	0.335	48	62	1c + 9	53	2c + 14
15104	"	0.589	0.350	59	54	18	49	2c + 23
15117	"	0.600	0.359	60	50	1c + 17	45	1c + 17
12307	0	0.691	0.499	72	62	1c + 7	36	2c + 6
12312	"	0.697	0.523	75	72	1c + 8	44	2c + 9
15107	"	0.592	0.277	47	45	1	1	1c
15112	"	0.596	0.474	80	56	1c + 4	34	1c + 3
12309	18000	0.693	0.662	96	61	2c + 1	11	1c
12316	"	0.701	0.708	101	74	2c + 1	4	1c + 3
15109	"	0.593	0.547	92	55	1c	5	2c
15116	"	0.599	0.664	109	50	1c	20	2c
12308	32000	0.692	0.951	137	44	2c	2	1c + 2
12314	"	0.699	1.19	170	59	1	1	2
15108	"	0.593	0.984	166	40	1c	4	1c
15114	"	0.597	0.857	144	45	2c	22	1c
19014	"	0.644	1.18	183	75	1c + 1	7	1c
12303	42800	0.686	0.892	130	70	6	29	6
12311	"	0.695	0.995	143	65	1c + 2	12	1c + 4
15103	"	0.589	1.19	201	45	1c	28	1c + 1

* For example, 2c + 3 means that there were five nuclei, one at each corner of the hole and three along the bore.

Table 8

FATIGUE TESTS WITHOUT HEAT - NOTCH $K_t = 2.3$

Average stress on net area lb/in^2	Specimen No.	Endurance (N) 10^5 cycles	Major fatigue crack		Minor fatigue crack		Estimated standard deviation of $\log_{10} N$
			Area on half the net section %	Number of damage nuclei*	Area on half the net section %	Number of damage nuclei*	
18000 ± 16000	16601	0.398	15	1c + 2	13	1c + 2	0.105
"	16605	0.581	15	2c	3	2c	
"	16610	0.300	26	1	1	2c + 1	
"	16615	0.497	25	2c + 3	16	5	
"	16619	0.377	29	1c + 2	9	2c	
"	18201	0.357	17	9	13	2c + 11	
"	18215	0.307	68	9	2	2c + 14	
18000 ± 15000	18216	0.296	52	2c + 12	17	1c	
18000 ± 14000	11701	0.701	36	2c + 1	17	1c	0.083
"	11705	0.552	34	2c	1	1c	
"	11710	0.649	40	1c + 1	1	1c	
"	11715	0.664	37	1c	16	1c	
"	11719	0.432	31	1c	1	1c + 1	
"	12301	0.705	35	1c	8	2c	
"	12305	0.728	50	1c + 2	23	3	
"	12310	0.600	41	2c	0	0	
"	12315	0.694	65	2c + 1	1	1c	
"	12319	0.754	52	1c	17	2c	
"	13701	0.701	43	1c	11	2c	
"	13705	0.676	35	2c	6	2c	
"	13710	0.671	42	1c	22	2c	
"	13715	0.549	36	2c	1	2c	
"	13719	0.683	59	2c	47	2c + 1	
"	14301	0.720	39	1c + 3	22	2	
"	14305	0.817	45	2c	25	2c	
"	14310	0.809	43	2c	9	2c	
"	14315	0.427	41	1c + 2	4	2c + 3	
"	14319	0.640	42	1c + 4	2	1c + 1	
"	14601	0.651	37	2c	8	1c	
"	14605	0.503	48	2c	14	1c + 4	
"	14609	0.823	38	2c	0	0	
"	14615	0.751	45	2c	14	1c	
"	14619	0.614	32	2c	3	1c	
"	15101	0.621	74	2c	2	1c	
"	15105	0.619	38	1c	3	1c	
"	15110	0.491	58	1c + 1	1	1c	
"	15115	0.604	42	1c	1	1c	
"	15119	0.650	44	1c	1	1c	
"	15401	0.813	32	1c	5	1c	
"	15405	0.712	56	2c	8	2c	
"	15409	0.680	60	1c	5	2c	

* For example, 2c + 3 means that there were five nuclei, one at each corner of the hole and three along the bore.

Table 8 (continued)

Average stress on net area lb/in ²	Specimen No.	Endurance (N) 10 ⁵ cycles	Major fatigue crack		Minor fatigue crack		Estimated standard deviation of log ₁₀ N
			Area on half the net section %	Number of damage nuclei*	Area on half the net section %	Number of damage nuclei*	
18000 ± 14000	15415	0.758	52	1c	0	0	
"	15419	0.701	41	2c	14	2c	
"	17101	0.644	61	2c + 1	21	1c + 1	
"	17105	0.524	42	2c + 1	1	1c + 1	
"	17110	0.603	43	2c + 2	10	1c	
"	17116	0.424	48	3	7	2c	
"	17119	0.706	65	1c + 1	1	1c + 2	
"	17402	0.865	48	1c + 1	0	0	
"	17406	0.406	45	1c	1	1c	
"	17410	0.891	57	1c	28	1c	
"	17415	0.804	46	2c	2	2c	
"	17419	0.918	59	2c + 1	9	2c	
"	17901	0.604	35	2c + 1	35	1c	
"	17905	0.625	51	1c	10	2c	
"	17910	0.698	49	2c	42	2c	
"	17915	0.400	48	2c + 1	1	2c	
"	17919	0.567	40	2c	12	2c	
"	18202	0.859	17	1c + 1	3	1c + 1	
"	18205	0.900	52	2c + 1	35	1c + 1	
"	18701	0.536	15	1c	8	3	
"	18705	0.586	29	3	8	1c	
"	18710	0.539	27	1c + 1	20	1	
"	18715	0.570	22	1c + 1	14	3	
"	18719	0.601	26	1c + 2	1	1c	
"	19001	0.644	57	1c + 2	1	1	
"	19005	0.734	56	1c + 1	12	1c + 1	
"	19010	0.613	60	3	13	1c + 1	
"	19015	0.770	40	1	9	1c	
"	19019	0.552	65	1c + 4	32	2c + 3	
"	19201	0.733	20	1c + 1	1	2	
"	19205	0.594	22	1c + 1	3	2	
"	19210	0.639	26	1c + 2	24	1c	
"	19215	0.534	23	1c + 4	17	1c + 2	
"	19219	0.580	22	2c + 8	12	8	
18000 ± 13000	18208	0.722	66	1c + 3	19	2c + 1	
18000 ± 12000	12313	1.10	56	2c	0	0	0.297
"	15106	0.887	47	1c	12	2c	
"	16206	4.63	60	1	0	0	
"	18203	1.21	19	1c	8	1	
"	18218	0.622	36	1c	5	1c + 2	
"	19002	1.29	48	1	0	0	
18000 ± 11000	18212	0.974	40	1c + 2	39	1c	
18000 ± 10000	12302	1.45	48	1c	0	0	0.238
"	15118	0.941	57	1c	0	0	

* For example, 2c + 3 means that there were five nuclei, one at each corner of the hole and three along the bore.

Table 8 (continued)

Average stress on net area lb/in ²	Specimen No.	Endurance (N) 10 ⁵ cycles	Major fatigue crack		Minor fatigue crack		Estimated standard deviation of log ₁₀ N
			Area on half the net section %	Number of damage nuclei*	Area on half the net section %	Number of damage nuclei*	
18000 ± 10000	16218	1.51	43	1c	0	0	
"	17118	1.30	48	1c	1	1c	
"	18206	2.35	48	1c	15	1c	
"	18209	4.47	32	1c	0	0	
18000 ± 9000	10601	61.5 UB	-	-	-	-	0.119**
"	10602	1.90	37	1c	1	1c	
"	10605	1.81	40	1c	0	0	
"	10610	1.82	33	1c	0	0	
"	10615	1.63	39	1c	0	0	
"	10618	1.85	34	2c	0	0	
"	11201	1.36	38	1c	1	1c	
"	11205	2.34	44	1c	0	0	
"	11207	2.04	39	1c	0	0	
"	11210	3.59	38	1c	2	1c	
"	11211	1.49	44	1c	0	0	
"	11215	2.11	37	1c	0	0	
"	11219	1.18	36	1c	2	1c	
"	13201	2.03	37	1c	0	0	
"	13205	1.64	42	1c	0	0	
"	13210	1.95	35	1c	1	1c	
"	13215	1.70	47	1c	0	0	
"	13219	2.34	42	1c	0	0	
"	16201	1.75	48	2c	0	0	
"	16205	2.08	39	1c	1	1c	
"	16210	1.95	38	1c	0	0	
"	16215	2.31	37	1c	0	0	
"	16219	1.66	55	1c	10	1c	
"	16701	1.55	43	2c	0	0	
"	16705	2.26	43	1c	1	1c	
"	16710	1.28	45	1c	0	0	
"	16715	1.74	40	1c	1	1c	
"	16718	2.13	38	1c	14	1c	
"	16719	28.4 UB	-	-	-	-	
"	17001	2.34	34	1c	0	0	
"	17006	2.07	39	1c	0	0	
"	17010	2.14	37	1c	0	0	
"	17015	2.28	40	1c	0	0	
"	17019	1.34	35	2c	0	0	
"	18207	3.00	29	1c	0	0	
"	18211	3.41	35	1c	0	0	
"	18219	2.19	43	1c	0	0	
18000 ± 8000	12306	1.62	38	1c	0	0	0.893**
"	15113	1.64	46	1c	0	0	
"	15402	1.80	45	1c	0	0	

* For example, 2c + 3 means that there were five nuclei, one at each corner of the hole and three along the bore.

** Standard deviation adjusted by Lariviere's method¹² for unbroken specimens.

UB = unbroken.

Table 8 (concluded)

Average stress on net area lb/in ²	Specimen No.	Endurance (N) 10 ⁵ cycles	Major fatigue crack		Minor fatigue crack		Estimated standard deviation of log ₁₀ N
			Area on half the net section %	Number of damage nuclei*	Area on half the net section %	Number of damage nuclei*	
18000 ± 8000	17106	2.08	41	1c	0	0	
"	18204	207 UB	-	-	-	-	
"	18213	65.9	35	1c	0	0	
18000 ± 7000	12318	3.73	62	1c	0	0	
"	16202	5.78	44	1c	0	0	
"	17902	2.61	41	1c	25	1c	
"	17906	3.19	47	1c	36	2c	
"	18210	205 UB	-	-	-	-	
"	19006	143 UB	-	-	-	-	
18000 ± 6500	17913	4.01	50	1c	1	1c	
18000 ± 6000	17102	5.89	50	1c	0	0	
"	17918	3.54	49	1c	0	0	

* For example, 2c + 3 means that there were five nuclei, one at each corner of the hole and three along the bore.

UB = unbroken.

Table 9

FATIGUE TESTS WITH PRIOR APPLICATION OF HEAT - NOTCH $K_t = 2.3$
1000h AT 150°C AT ZERO APPLIED STRESS

Average stress on net area lb/in ²	Specimen No.	Endurance (N) 10 ⁵ cycles	Major fatigue crack		Minor fatigue crack		Estimated standard deviation of log ₁₀ N
			Area on half the net section %	Number of damage nuclei*	Area on half the net section %	Number of damage nuclei*	
18000 ± 16000	16007	0.241	70	8	27	16	
18000 ± 14000	15802	0.664	64	2	26	2	0.112
"	15814	0.440	43	1c + 4	27	6	
"	15816	0.389	45	1c + 5	12	1c + 7	
"	19203	0.572	35	12	19	1c + 9	
"	16006	0.360	46	5	1	4	
"	19211	0.508	25	2c + 18	14	12	
"	16016	0.453	63	7	24	8	
"	16613	0.298	47	1c + 6	2	5	
18000 ± 12000	15807	0.728	46	1c + 1	2	1c	0.121
"	15817	0.674	62	1	1	1c + 1	
"	16003	0.619	62	1	4	2	
"	16009	0.477	68	1c + 5	1	1c + 1	
"	16602	0.391	39	1c + 1	1	2	
"	16612	0.822	52	1c + 2	8	2c + 1	
19000 ± 10000	15806	1.22	62	1c	0	0	0.093
"	16004	1.33	63	1	2	1c	
"	16013	1.20	51	1c + 1	2	2c	
"	16014	1.48	43	1c	0	0	
"	16608	0.867	61	5	28	1c + 2	
"	16614	0.900	56	1c + 1	34	1c + 2	
18000 ± 9000	11203	1.36	50	1c + 2	4	1	
"	11218	1.28	39	1c	24	1c + 2	
18000 ± 8000	15811	2.27	48	1c	14	1c	0.107
"	16017	2.06	53	1c	1	1c	
"	16018	1.82	52	1c	0	0	
"	16603	1.38	42	1c	3	1	
"	16611	1.91	44	1c	1	1c	
"	16616	1.20	47	2	1	1	
18000 ± 7000	15812	2.63	67	1c	1	1	0.077**
"	15813	2.98	43	1c	1	1	
"	16002	204 UB	-	-	-	-	
"	16012	3.52	43	1c	0	0	
"	16609	3.45	45	1c	0	0	
"	16617	2.64	51	1c	1	1c	
18000 ± 6000	15803	204 UB	-	-	-	-	
"	15808	211 UB	-	-	-	-	
"	16011	180	59	1	0	0	
"	16606	2.96	51	1c	0	0	
"	16607	208 UB	-	-	-	-	
"	16618	2.67	55	1c + 1	0	0	

* For example, 2c + 3 means that there were five nuclei, one at each corner of the hole and three along the bore.

** Standard deviation adjusted by Lariviere's method¹² for unbroken specimens.

UB = unbroken.

Table 10

FATIGUE TESTS WITH PRIOR APPLICATION OF HEAT - NOTCH $K_t = 2.3$
1000h AT 150°C WITH 18000 lb/in² APPLIED STRESS

Average stress on net area lb/in ²	Specimen No.	Endurance (N) 10 ⁵ cycles	Major fatigue crack		Minor fatigue crack		Estimated standard deviation of log ₁₀ N
			Area on half the net section %	Number of damage nuclei*	Area on half the net section %	Number of damage nuclei*	
18000 ± 14000	17505	0.369	71	1c + 4	2	1	0.109
"	17511	0.573	57	2	12	1c + 1	
"	18702	0.540	50	1	24	4	
"	17513	0.542	58	1c + 5	1	5	
"	18707	0.485	47	1c + 6	0	0	
"	19602	0.652	46	1c + 3	22	1c + 4	
"	19607	0.386	49	1c + 8	1	1c + 1	
"	19610	0.784	45	2c + 1	1	1c	
18000 ± 12000	17507	3.70	43	1c	0	0	0.215
"	17512	2.08	50	1c + 1	0	0	
"	17516	1.50	47	1	0	0	
"	19601	1.24	41	1c	5	1c	
"	19606	0.979	55	4	51	4	
"	19609	2.61	38	1c	0	0	
18000 ± 10000	17509	6.79	44	1c	0	0	0.430
"	17514	3.67	55	1c	0	0	
"	17517	49.1	62	1	0	0	
"	19603	3.99	43	1	39	1c	
"	19615	4.61	39	1c	0	0	
"	19617	4.47	38	1c	0	0	
18000 ± 9000	10603	2.28	38	1c	0	0	-
"	10611	3.15	37	1c	0	0	
18000 ± 8000	17503	220 UB	-	-	-	-	-
"	17506	241 UB	-	-	-	-	
"	17510	251 UB	-	-	-	-	
"	19604	3.38	52	2c	0	0	
"	19612	2.88	46	1c	0	0	
"	19616	10.3	40	1c	0	0	
18000 ± 7000	17501	86.4 UB	-	-	-	-	
"	17515	306 UB	-	-	-	-	
"	17518	213 UB	-	-	-	-	
"	17519	213 UB	-	-	-	-	
"	19614	4.34	46	1c	0	0	
"	19618	6.65	34	1	0	0	

* For example, 2c + 3 means that there were five nuclei, one at each corner of the hole and three along the bore.

UB = unbroken.

Table 11

FATIGUE TESTS WITHOUT HEAT - NOTCH $K_t = 3.4$

Average stress on net area lb/in^2	Specimen No.	Endurance (N) 10^5 cycles	Major fatigue crack		Minor fatigue crack		Estimated standard deviation of $\log_{10} N$
			Area on half the net section %	Number of damage nuclei*	Area on half the net section %	Number of damage nuclei*	
18000 \pm 10000	17302	0.492	52	1c + 15	42	1c + 9	0.0533
"	17310	0.431	62	2c + 30	49	2c + 27	
"	17315	0.515	49	1c + 12	48	17	
"	18302	0.378	43	1c + 15	38	1c + 12	
"	19118	0.430	65	1c + 12	54	1c + 11	
18000 \pm 9000	11901	0.537	57	1c + 8	47	8	0.0675
"	11905	0.481	40	1c + 6	16	1c + 9	
"	11910	0.583	48	2c + 6	34	1c + 4	
"	11915	0.571	58	1c + 7	44	1c + 9	
"	11919	0.464	50	11	27	8	
"	12203	0.662	50	5	37	5	
"	12207	0.621	41	4	18	5	
"	12801	0.619	58	8	34	2c + 8	
"	12805	0.501	52	1c + 11	38	2c + 8	
"	12810	0.535	50	1c + 12	45	2c + 13	
"	12815	0.483	46	2c + 11	37	1c + 14	
"	12819	0.492	41	2c + 13	35	2c + 11	
"	14201	0.628	59	1c + 10	38	1c + 6	
"	14205	0.554	41	2c + 13	40	6	
"	14210	0.464	41	16	17	9	
"	14215	0.563	52	12	29	1c + 7	
"	14219	0.614	48	5	33	1c + 3	
"	17301	0.866	40	1c + 7	35	1c + 7	
18000 \pm 8000	10201	0.945	63	1c + 5	5	1c + 10	0.0898
"	10205	0.782	52	1c + 4	37	5	
"	10210	0.735	55	4	31	2	
"	10215	1.12	59	6	25	1c + 10	
"	10219	0.987	61	1c + 4	25	1c + 3	
"	10801	1.18	45	1c + 7	8	9	
"	10805	1.11	37	1c + 3	36	3	
"	10810	1.10	33	1c + 3	30	1c + 1	
"	10815	1.44	40	1c	11	9	
"	10819	1.24	44	1c + 2	24	1c + 3	
"	11301	1.22	54	2c + 3	38	2c + 6	
"	11305	1.27	71	2c + 3	24	1c + 9	
"	11310	1.36	48	2c + 6	39	2c + 10	
"	11315	1.34	70	2c + 3	2	1c + 5	
"	11319	1.03	43	1c	37	2c + 2	
"	12204	1.45	41	1c + 1	29	1c + 4	
"	12219	1.11	44	1	29	1c + 1	
"	13301	1.18	62	4	41	1c + 7	
"	13305	1.35	46	1c + 3	5	1c + 3	
"	13310	1.46	39	2	9	1	
"	13315	1.19	40	1c + 2	30	2c + 4	

* For example, 2c + 3 means that there were five nuclei, one at each corner of the hole and three along the bore.

Table 11 (continued)

Average stress on net area lb/in ²	Specimen No.	Endurance (N) 10 ⁵ cycles	Major fatigue crack		Minor fatigue crack		Estimated standard deviation of log ₁₀ N
			Area on half the net section %	Number of damage nuclei*	Area on half the net section %	Number of damage nuclei*	
18000 ± 8000	13319	0.911	49	1c + 5	5	2c + 6	
"	15001	1.74	41	2	21	1c	
"	15005	1.17	44	1c + 1	19	1c + 5	
"	15011	1.01	49	1c + 2	32	1	
"	15015	1.06	55	2c + 2	2	8	
"	15018	1.14	33	2c	27	1c + 2	
"	15901	1.12	43	1c	36	2c	
"	15905	1.08	59	2c	21	1c	
"	15910	1.06	45	1c	31	1c	
"	15915	1.08	75	2c + 3	6	1c + 1	
"	15919	1.10	42	1c	9	2	
"	16501	0.760	54	19	21	16	
"	16505	1.09	42	1	25	1c + 5	
"	16510	0.849	63	12	30	1c + 9	
"	16515	1.03	61	2c + 8	54	12	
"	16519	1.11	60	2c + 9	1	1c + 2	
"	16801	1.28	54	1c + 4	19	1c + 6	
"	16805	1.78	38	2c	14	2c + 6	
"	16810	1.58	63	1c + 2	56	6	
"	16815	1.37	48	1c + 1	30	2c + 4	
"	16819	1.33	39	1c	39	3	
"	16901	0.935	36	1c + 9	30	1c + 6	
"	16905	0.904	61	1c + 4	33	1c + 3	
"	16910	0.773	46	5	16	1c + 15	
"	16915	0.695	59	10	44	1c + 8	
"	16919	1.18	73	2c + 7	16	9	
"	17201	1.24	61	2c + 6	49	2c + 5	
"	17205	1.07	43	2c	31	1c + 1	
"	17210	1.46	63	1c + 2	2	10	
"	17215	1.03	43	3	30	2	
"	17219	1.27	40	1c	39	1c	
"	17303	1.19	32	1c + 1	23	1c + 1	
"	18301	1.72	39	1c	38	1	
"	18305	1.28	41	1c	33	1c	
"	18310	1.25	47	2c	44	2	
"	18315	1.27	46	1c + 1	12	10	
"	18319	1.24	45	5	11	1c + 1	
"	19101	1.00	63	2c + 6	48	2c + 9	
"	19105	0.995	39	1c + 3	33	2c + 9	
"	19110	0.979	53	1c + 3	28	1c + 2	
"	19115	0.878	47	1c + 2	34	1c + 3	
"	19119	1.13	66	1c + 8	24	1c + 5	
"	19501	0.647	70	1c + 11	20	18	
"	19505	1.09	72	1c + 7	1	4	
"	19510	0.950	46	9	42	1c + 12	

* For example, 2c + 3 means that there were five nuclei, one at each corner of the hole and three along the bore.

Table 11 (continued)

Average stress on net area lb/in ²	Specimen No.	Endurance (N) 10 ⁵ cycles	Major fatigue crack		Minor fatigue crack		Estimated standard deviation of log ₁₀ N
			Area on half the net section %	Number of damage nuclei*	Area on half the net section %	Number of damage nuclei*	
18000 ± 8000	19515	0.992	53	2c + 12	19	6	
"	19519	1.11	55	10	9	7	
18000 ± 7000	12217	1.90	63	1c + 1	0	0	0.0642
"	12218	1.55	44	1	2	2	
"	17304	2.17	44	2c	0	0	
"	18318	1.56	45	1c	38	1c	
"	19102	1.93	50	1c + 6	46	1c + 3	
"	19113	2.14	41	1c + 1	2	3	
18000 ± 6000	12205	3.16	40	1c	0	0	0.225
"	12212	3.25	50	1c	6	1	
"	17305	9.00	55	1c	3	1	
"	17311	2.44	41	1c	39	1	
"	18313	2.03	49	1c	41	1c	
"	19106	2.99	44	1c	17	1c	
18000 ± 5500	17306	2.96	43	1c	1	1c + 2	
18000 ± 5000	14701	4.87	45	1c	2	3	0.340**
"	14705	3.80	38	1c	31	1c	
"	14711	4.38	52	1c	47	1c	
"	14715	5.52	55	1c	1	4	
"	14718	5.31	47	1c	3	3	
"	15501	17.5	44	1c	1	2	
"	15502	4.73	45	1c	1	1c + 2	
"	15505	8.81	42	1c	1	1c + 1	
"	15507	4.42	42	1c	29	1c	
"	15510	11.2	49	1c	1	1c + 2	
"	15514	4.34	52	1c	1	1c + 2	
"	15519	4.20	42	1c	30	1c	
"	17312	4.74	81	2c	0	0	
"	17313	4.81	55	1c	16	1c + 3	
"	17801	7.63	59	1c	0	0	
"	17802	28.2	19	1c	1	1c + 4	
"	17805	4.58	42	1c	0	0	
"	17806	5.24	52	1c	1	1c + 2	
"	17810	6.13	47	1c	38	1c	
"	17811	212 UB	-	-	-	-	
"	17815	28.1	46	1c	1	1c + 1	
"	17818	68.5	46	1c	1	2	
"	17819	16.3	46	1c	0	0	
"	18601	4.23	44	1	1	1c	
"	18605	4.94	43	1c	1	1c	
"	18610	5.54	51	1c	6	1	
"	18615	6.07	43	1c	1	1c + 2	
"	18618	5.51	57	1c	3	1c + 2	

* For example, 2c + 3 means that there were five nuclei, one at each corner of the hole and three along the bore.

** Standard deviation adjusted by Lariviere's method¹² for unbroken specimens.

UB = unbroken.

Table 11 (concluded)

Average stress on net area lb/in ²	Specimen No.	Endurance (N) 10 ⁵ cycles	Major fatigue crack		Minor fatigue crack		Estimated standard deviation of log ₁₀ N
			Area on half the net section %	Number of damage nuclei*	Area on half the net section %	Number of damage nuclei*	
18000 ± 5000	18619	102 UB	-	-	-	-	
"	19401	11.2	48	1c	1	4	
"	19405	5.12	50	1c	1	1	
"	19410	3.77	49	1c	29	1c	
"	19415	4.26	49	1c	16	1c	
"	19419	3.33	49	1c	34	1c	
18000 ± 4000	15002	228 UB	-	-	-	-	-
"	15007	9.95	50	1c	0	0	
"	17307	8.73	59	1c	1	1c + 1	
"	18306	168	46	1c	1	1	
"	18607	235 UB	-	-	-	-	
"	18613	206 UB	-	-	-	-	
18000 ± 3500	11913	210 UB	-	-	-	-	-
18000 ± 3000	17308	200 UB	-	-	-	-	-

* For example, 2c + 3 means that there were five nuclei, one at each corner of the hole and three along the bore.

** Standard deviation adjusted by Lariviere's method¹² for unbroken specimens.

UB = unbroken.

Table 12

FATIGUE TESTS WITH PRIOR APPLICATION OF HEAT - NOTCH $K_t = 3.4$
1000h AT 150°C AT ZERO APPLIED STRESS

Average stress on net area lb/in ²	Specimen No.	Endurance (N) 10 ⁵ cycles	Major fatigue crack		Minor fatigue crack		Estimated standard deviation of log ₁₀ N
			Area on half the net section %	Number of damage nuclei*	Area on half the net section %	Number of damage nuclei*	
18000 ± 10000	10818	0.436	67	17	66	18	0.0718
"	13313	0.457	65	13	65	12	
"	16408	0.298	64	1c + 10	54	15	
"	16409	0.335	68	10	45	11	
"	16419	0.415	60	14	54	1c + 13	
"	19518	0.398	58	13	54	15	
18000 ± 9000	10813	0.478	48	16	38	19	0.0639
"	11903	0.566	56	20	42	14	
"	14702	0.559	62	12	59	1c + 11	
"	11911	0.526	50	12	48	17	
"	16402	0.385	57	18	52	2c + 20	
"	16415	0.394	56	17	52	1c + 12	
"	16802	0.509	49	9	35	1c + 9	
"	19513	0.488	51	1c + 7	36	6	
18000 ± 8000	13307	0.810	55	18	46	11	0.084
"	14218	0.877	49	1c + 10	49	1c + 10	
"	15003	0.819	51	10	37	6	
"	16403	0.502	48	7	40	6	
"	15013	0.857	36	6	35	11	
"	16417	0.736	50	10	44	8	
"	16918	0.613	55	4	29	1c + 6	
"	19418	0.788	64	7	36	4	
18000 ± 7000	10802	2.27	52	2c + 3	9	2c + 10	0.172
"	14707	1.87	50	1	19	1c + 7	
"	16404	1.13	45	1c + 2	36	1c + 6	
"	16410	0.884	57	1c + 8	12	2c + 6	
"	16913	0.858	54	1c + 4	33	2c + 3	
"	19506	1.31	71	3	1	2	
18000 ± 6000	13318	1.87	45	1	38	1c + 2	0.101
"	14207	3.20	43	1c	3	1c + 5	
"	16401	1.87	58	1c + 2	2	2c + 5	
"	16405	1.63	49	1c + 6	13	1c + 2	
"	16412	2.01	61	1c + 4	40	1c + 1	
"	16813	2.13	50	1c + 2	19	2c + 2	
18000 ± 5000	10807	4.79	51	1c	9	1c + 3	0.486
"	14213	46.0	53	1c	2	2	
"	16406	4.15	60	1c	4	1c + 2	
"	16413	3.55	57	1	12	1	
"	16418	4.79	67	1c + 1	11	1c	
"	16902	4.21	41	1c	40	1c	
"	17804	4.72	47	1c	14	1c	

* For example, 2c + 3 means that there were five nuclei, one at each corner of the hole and three along the bore.

Table 12 (concluded)

Average stress on net area lb/in ²	Specimen No.	Endurance (N) 10 ⁵ cycles	Major fatigue crack		Minor fatigue crack		Estimated standard deviation of log ₁₀ N
			Area on half the net section %	Number of damage nuclei*	Area on half the net section %	Number of damage nuclei*	
18000 ± 5000	17808	26.3	54	1c	1	3	
"	17812	3.62	44	1c	0	0	
"	17813	46.6	56	1c	21	1	
"	17817	4.54	52	1c	23	1c + 2	
"	18603	3.12	60	1c + 1	13	2c	
"	18611	4.90	55	1c	52	1c	
18000 ± 4000	16407	104	54	1c + 3	40	1c	0.464
"	16411	7.83	52	1c	40	1c	
"	16416	11.2	72	1c	15	1c	
"	16807	43.1	52	1c	8	5	
"	16907	9.48	54	1c	1	1	
"	19502	8.57	59	1c	31	1c	

* For example, 2c + 3 means that there were five nuclei, one at each corner of the hole and three along the bore.

Table 13

FATIGUE TESTS WITHOUT HEAT - LUG SPECIMEN

Average stress on net area lb/in^2	Specimen No.	Endurance (N) 10^5 cycles	Major fatigue crack		Minor fatigue crack		Estimated standard deviation of $\log_{10} N$
			Area on half the net section %	Number of damage nuclei*	Area on half the net section %	Number of damage nuclei*	
15000 \pm 6150	50501	0.967	86	6	62	7	0.083
"	50505	0.765	78	8	44	6	
"	50510	0.871	74	1c + 7	74	1c + 7	
"	50515	0.796	83	2c + 5	65	1c + 5	
"	50519	0.804	78	1c + 5	71	3	
"	52001	0.564	79	16	60	10	
"	52005	0.580	80	1c + 6	58	9	
"	52010	0.509	73	1c + 7	41	6	
"	52015	0.599	76	1c + 6	54	1c + 6	
"	52019	0.638	79	8	57	7	
"	53101	0.811	73	6	63	6	
"	53105	0.727	80	12	55	1c + 6	
"	53110	0.754	82	8	59	1c + 9	
"	53115	0.673	80	8	62	9	
"	53119	0.779	76	1c + 4	45	2	
"	53803	0.817	78	6	53	7	
"	53815	0.561	70	16	64	1c + 14	
"	58401	0.624	80	7	70	2	
"	58405	0.554	77	10	66	1c + 8	
"	58410	0.532	82	1c + 9	62	11	
"	58415	0.556	78	6	70	5	
"	58419	0.516	76	6	70	12	
15000 \pm 5110	53804	1.02	79	1c + 5	53	2c + 4	
"	53817	0.943	74	1c + 6	68	5	
15000 \pm 5000	50402	1.14	83	3	54	1c + 7	0.029
"	50411	0.980	76	1c + 6	67	1c + 6	
"	50416	1.08	78	5	75	5	
"	53102	1.12	70	1c + 3	68	1c + 7	
15000 \pm 4090	53805	2.88	78	4	62	1c + 1	
"	53818	9.54	80	1c + 5	60	2c	
15000 \pm 4000	50403	2.37	80	4	62	4	0.066
"	50418	1.71	78	1c + 1	65	6	
"	53107	1.92	75	2	68	1c + 4	
"	53113	1.72	82	1c + 2	34	1c + 1	
15000 \pm 3075	53801	9.06	84	1	21	2	
15000 \pm 3000	50405	4.86	79	3	44	2	0.071
"	50409	4.52	78	3	69	2	
"	50412	3.86	79	2	42	1c + 1	
"	50507	3.45	76	1	68	2	
"	51513	5.10	81	2	58	2	

* For example, 2c + 1 means that there were three nuclei, one at each corner of the hole and one along the bore.

Table 13 (concluded)

Average stress on net area lb/in^2	Specimen No.	Endurance (N) 10^5 cycles	Major fatigue crack		Minor fatigue crack		Estimated standard deviation of $\log_{10} N$
			Area on half the net section %	Number of damage nuclei*	Area on half the net section %	Number of damage nuclei*	
15000 \pm 2045	50518	20.0	82	1	58	1c	0.157
"	51502	21.6	81	1c	32	1c + 1	
"	51505	23.3	83	4	44	1c + 3	
"	51510	19.4	79	4	53	4	
"	51515	18.7	85	2	5	1c	
"	51518	20.2	85	2	25	5	
"	52901	16.3	83	1c + 1	38	1c + 1	
"	52905	14.8	82	1c	36	1	
"	52910	11.1	79	1	17	1c + 3	
"	52915	24.6	86	1c + 1	49	1c + 1	
"	52919	25.0	77	1c + 1	34	1c + 2	
"	53807	49.1	87	2	49	2	
"	53808	31.1	82	1c + 2	18	1c + 2	
"	53816	24.3	74	1c	39	1c	
"	55201	16.7	80	1c	55	1	
"	55205	16.5	81	1	33	1c + 2	
"	55210	13.5	76	1c	25	1c + 6	
"	55215	11.8	76	1c	35	1c	
"	55219	15.1	81	1	48	1	
"	55601	12.4	79	1c + 5	16	1c + 1	
"	55605	7.67	83	1	1	3	
"	55610	14.5	80	1c + 2	67	7	
"	55615	14.4	80	1c + 2	40	3	
"	55619	15.9	82	1c + 1	45	6	
"	58101	11.2	83	1	34	2c	
"	58105	15.4	76	2	33	1c + 2	
"	58110	16.2	76	1c + 1	65	2	
"	58115	14.4	73	1	40	1	
"	58119	12.1	80	1c + 1	10	1c	
18000 \pm 2000	51819	16.6	83	1c + 3	20	1	
18000 \pm 1708	53806	38.9	84	1c + 1	5	1c	
18000 \pm 1500	50406	64.4	84	1c + 1	5	1c + 2	0.128
"	50408	31.1	84	1c + 1	8	1c	
"	50414	30.0	83	1	1	4	
"	50513	31.2	79	1	68	2	
"	51507	36.4	85	1c	4	1c + 1	
"	52902	31.2	83	2	1	2c	

* For example, 2c + 1 means that there were three nuclei, one at each corner of the hole and one along the bore.

Table 14

FATIGUE TESTS WITH PRIOR APPLICATION OF HEAT - LUG SPECIMEN
1000h AT 150°C AT ZERO APPLIED STRESS

Average stress on net area lb/in ²	Specimen No.	Endurance (N) 10 ⁵ cycles	Major fatigue crack		Minor fatigue crack		Estimated standard deviation of log ₁₀ N
			Area on half the net section %	Number of damage nuclei*	Area on half the net section %	Number of damage nuclei*	
18000 ± 7000	50410	0.590	62	2	37	1c + 2	
15000 ± 6150	50503	0.777	83	5	43	5	
"	50511	0.638	82	1c + 3	78	7	
15000 ± 6000	51809	0.773	87	1c + 2	65	1	0.030
"	51813	0.698	77	1	36	1c + 2	
"	51814	0.750	68	1c + 1	64	2	
"	52907	0.739	82	1c	64	2c + 3	
"	57713	0.695	74	1c + 4	42	2c + 2	
"	58402	0.836	81	4	50	1c + 4	
15000 ± 5000	51801	1.09	76	2c + 1	74	2	0.048
"	51803	1.26	79	2	50	3	
"	51807	1.00	72	2	71	1c + 1	
"	52018	0.968	79	2c + 1	48	1c + 1	
"	58406	1.03	83	1c + 1	37	1c + 2	
"	58813	1.23	81	1c + 1	63	1c	
15000 ± 4000	51805	1.92	82	3	44	2	0.063
"	51815	1.49	83	1c	5	2	
"	51816	1.96	78	1	56	3	
"	52007	1.43	84	1c + 2	24	1c	
"	55602	1.66	78	1c	54	1c + 1	
"	58418	1.98	82	1c + 2	79	2c + 1	
15000 ± 3000	50404	3.18	73	2	64	1c	0.090
"	50417	2.52	85	1	2	1c + 1	
"	51806	4.58	80	1c	49	1c	
"	51808	3.13	86	1c	22	1c	
"	52913	3.96	82	1	0	0	
"	55606	3.40	80	1c	5	1c + 1	
15000 ± 2045	52903	18.8	82	5	20	3	
"	52911	17.7	78	4	71	1	
15000 ± 2000	50419	7.85	82	1	6	.	0.173
"	51810	19.0	84	1c	10	2	
"	51818	11.4	82	1c	3	2	
"	52002	15.4	79	1c + 1	35	1c	
"	52918	17.6	82	1c + 1	0	0	
"	58413	24.0	88	1	10	2c	
15000 ± 1500	50407	61.9	82	1c	50	2	0.209
"	50413	37.2	84	1	0	0	
"	51802	23.0	84	1c	1	1	
"	51811	85.2	85	1c + 1	0	0	
"	51812	30.6	86	1c + 1	0	0	
"	52013	34.9	87	1	0	0	

* For example, 2c + 1 means that there were three nuclei, one at each corner of the hole and one along the bore.

REFERENCES

- | <u>No.</u> | <u>Author</u> | <u>Title, etc.</u> |
|------------|-----------------------------------|---|
| 1 | J.R. Heath-Smith
F.E. Kiddle | Influence of ageing and creep on fatigue of structural elements in an Al 6% Cu alloy.
In Thermal and High Strain Fatigue, the Metals and Metallurgy Trust, pp.391-415 (1967) |
| 2 | J.R. Heath-Smith
Judy E. Aplin | The effect of an application of heat on the fatigue performance under random loading of a notched specimen of DTD 5014 (RR58) material.
ARC Current Paper No.1221, HMSO (1972) |
| 3 | J.R. Heath-Smith
F.E. Kiddle | Effect of interrupting fatigue by periods of heat for aluminium alloy structural elements.
In Fatigue at Elevated Temperatures, A.E. Carden, A.J. McEvily and C.H. Wells, eds.
ASTM STP 520 pp.500-511 (1973) |
| 4 | F.E. Kiddle | Fatigue endurance, crack sensitivity and nucleation characteristics of structural elements in four aluminium-copper alloys.
ARC Current Paper No.1259, HMSO (1974) |
| 5 | F.E. Kiddle | The residual static strength of fatigue cracked lug specimens of four aluminium-copper alloys.
RAE Technical Report 73084 (1974) |
| 6 | P.J.E. Forsyth | The microstructural changes that drilling and reaming can cause in the bore of holes in DTD 5014 (RR58 extrusions) and the effects of subsequent heating.
In Aircraft Engineering, pp.20-23, November 1972 |
| 7 | - | Comparison of samples.
Royal Aeronautical Society, Engineering Sciences Data, Fatigue sub-series. Item 68016 (1968) |
| 8 | P.R. Edwards | Cumulative damage in fatigue with particular reference to the effects of residual stresses.
RAE Technical Report 69237 (1969) |

REFERENCES (concluded)

<u>No.</u>	<u>Author</u>	<u>Title, etc.</u>
9	P.R. Edwards	An experimental study of the stress histories at stress concentrations in aluminium alloy specimens under variable amplitude loading sequences. RAE Technical Report 70004 (1970)
10	E. Maurin W. Barrois	Effect of frequency and test temperature on the fatigue life of A-U29N-T6 sheet specimens and assemblies (in French). In Meeting of International Committee on Aeronautical Fatigue, Stockholm, May 1969.
11	L.A. Imig	Effect of initial loads and of moderately elevated temperature on the room-temperature fatigue life of Ti-8Al-1Mo-1V titanium alloy sheet. NASA Technical Note D-4061 (1967)
12	J.S. Lariviere	Calculation of the operating life of helicopter blades. Note STA/VT No.165.
13	M.S. Hunter W.G. Fricke	Fatigue crack propagation in aluminium alloys Proc. ASTM, Vol.56, 1038-1050 (1956)

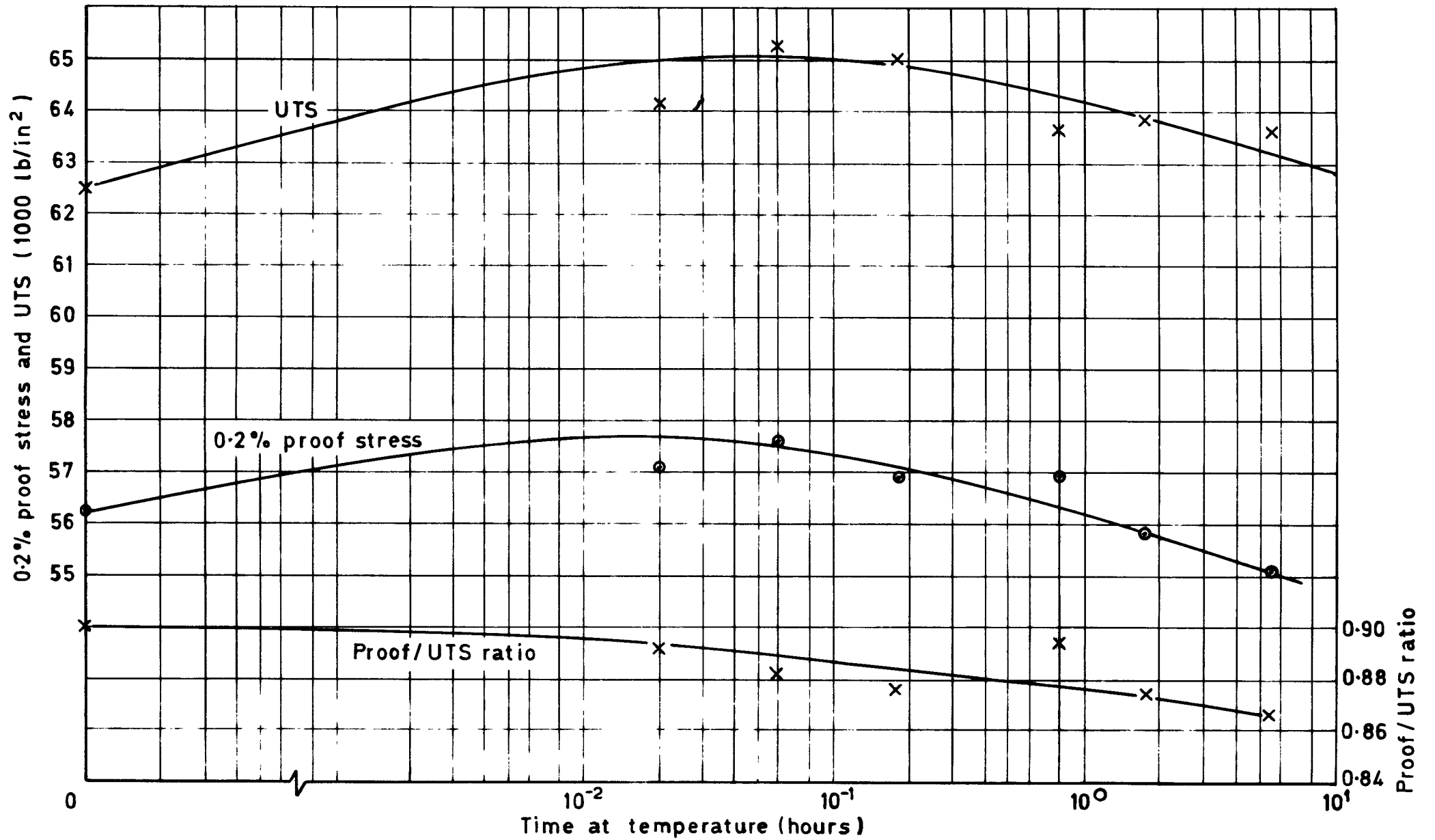

Fig.1 Variation of tensile properties with additional heating at 200°C

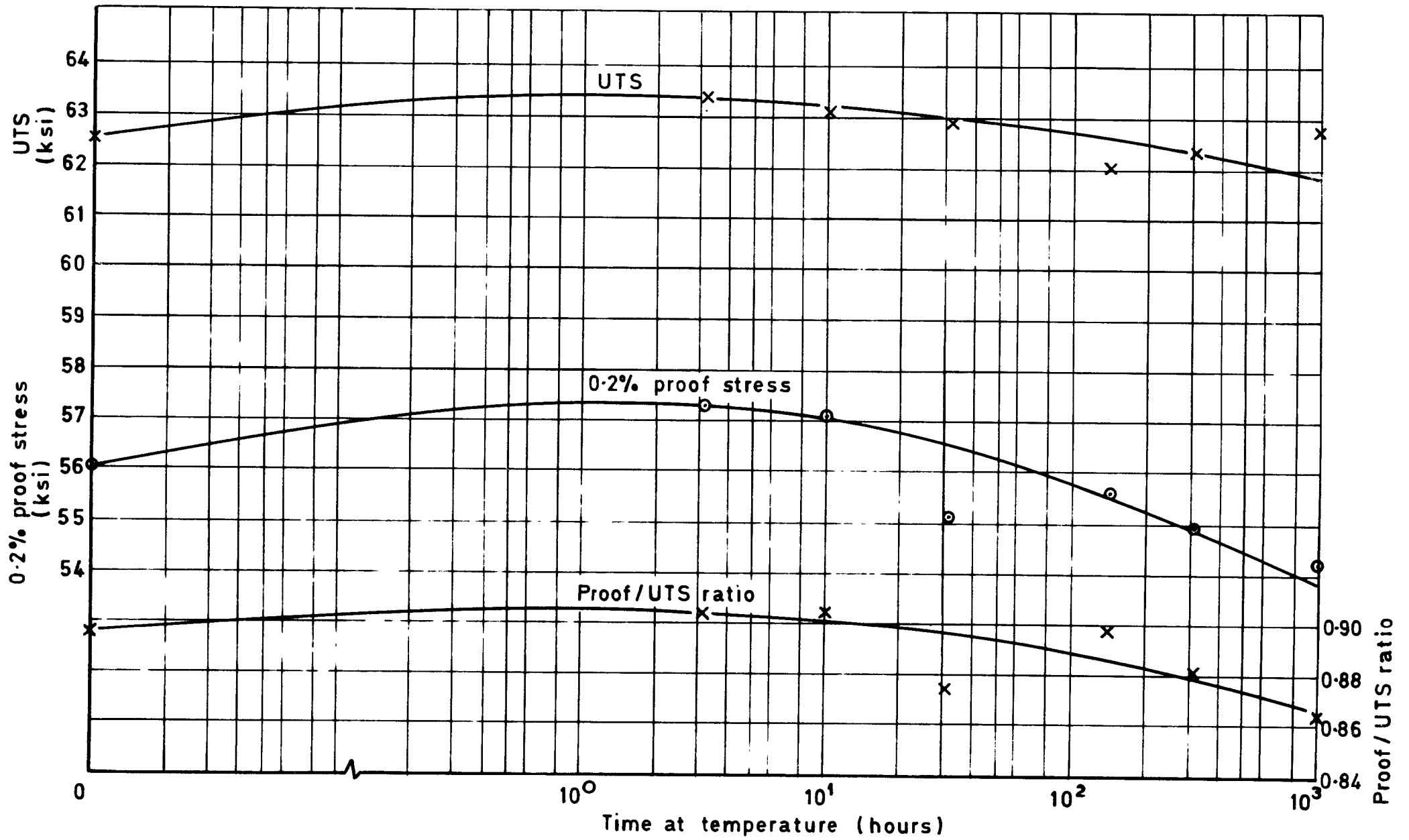
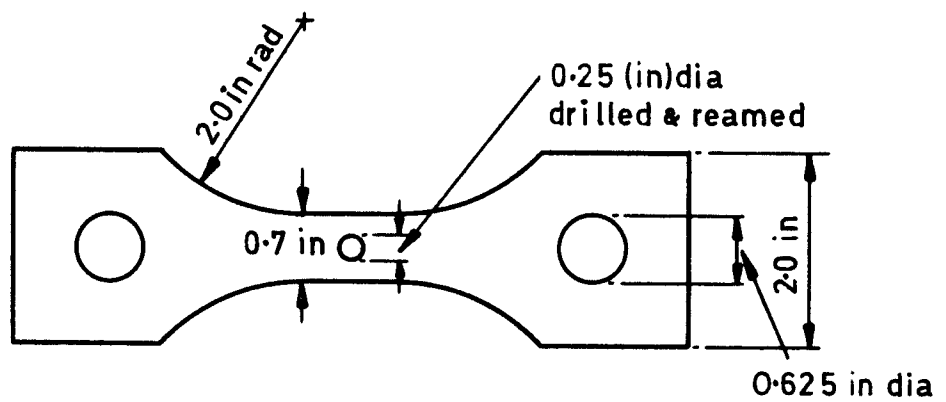
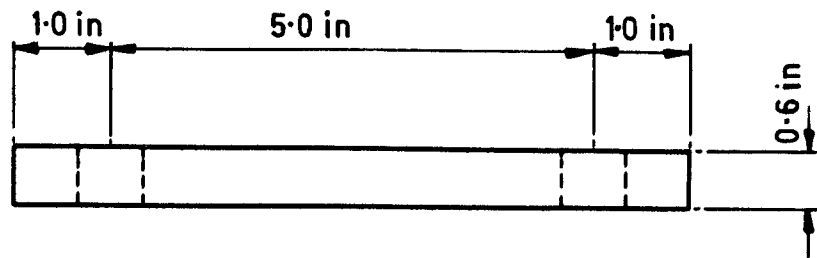
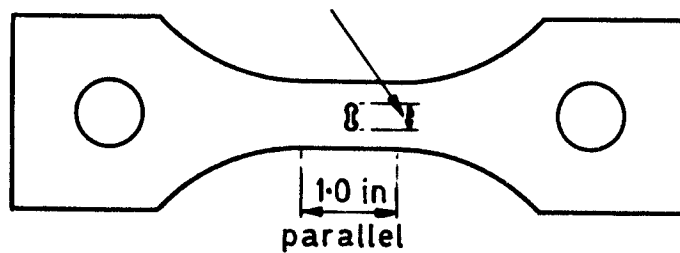

Fig.2 Variation of tensile properties with additional heating at 150°C



a Notch $K_t = 2.3$

Overall width 0.25 in
 consisting of two 0.0625 in dia
 drilled & reamed holes connected
 by a spark eroded slot



b Notch $K_t = 3.4$

Surface finish:- 8 to 16 micro inches
 Edges of holes at test section sharp and free from burrs

Fig.3a&b Notched specimens

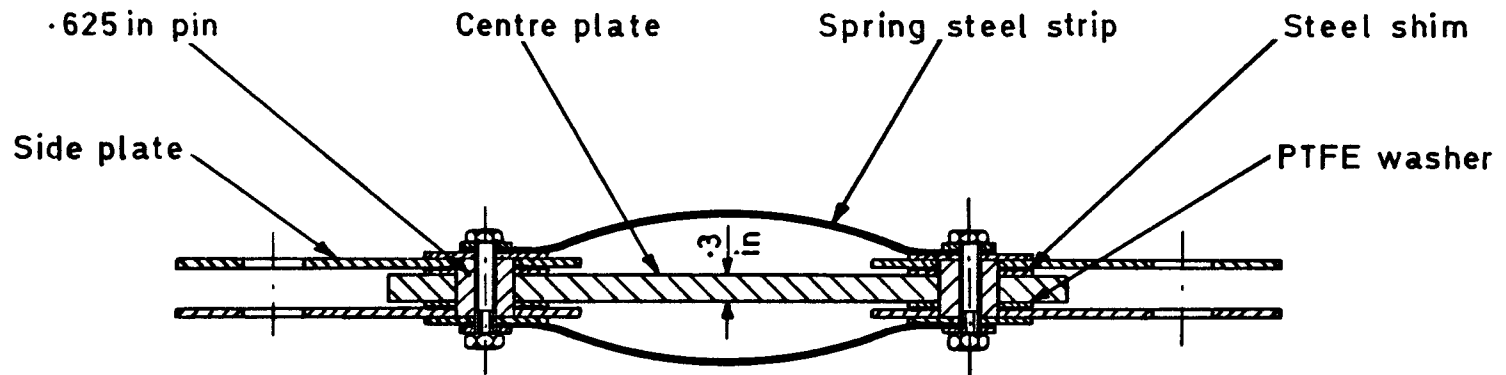
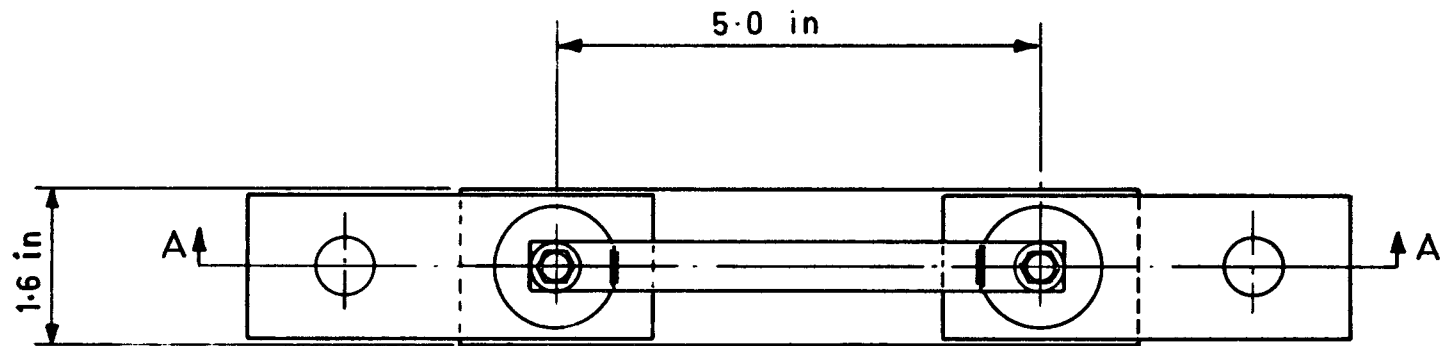

Surface finish
8 to 16 micro-inches

Section AA

Fig.4 Lug specimen

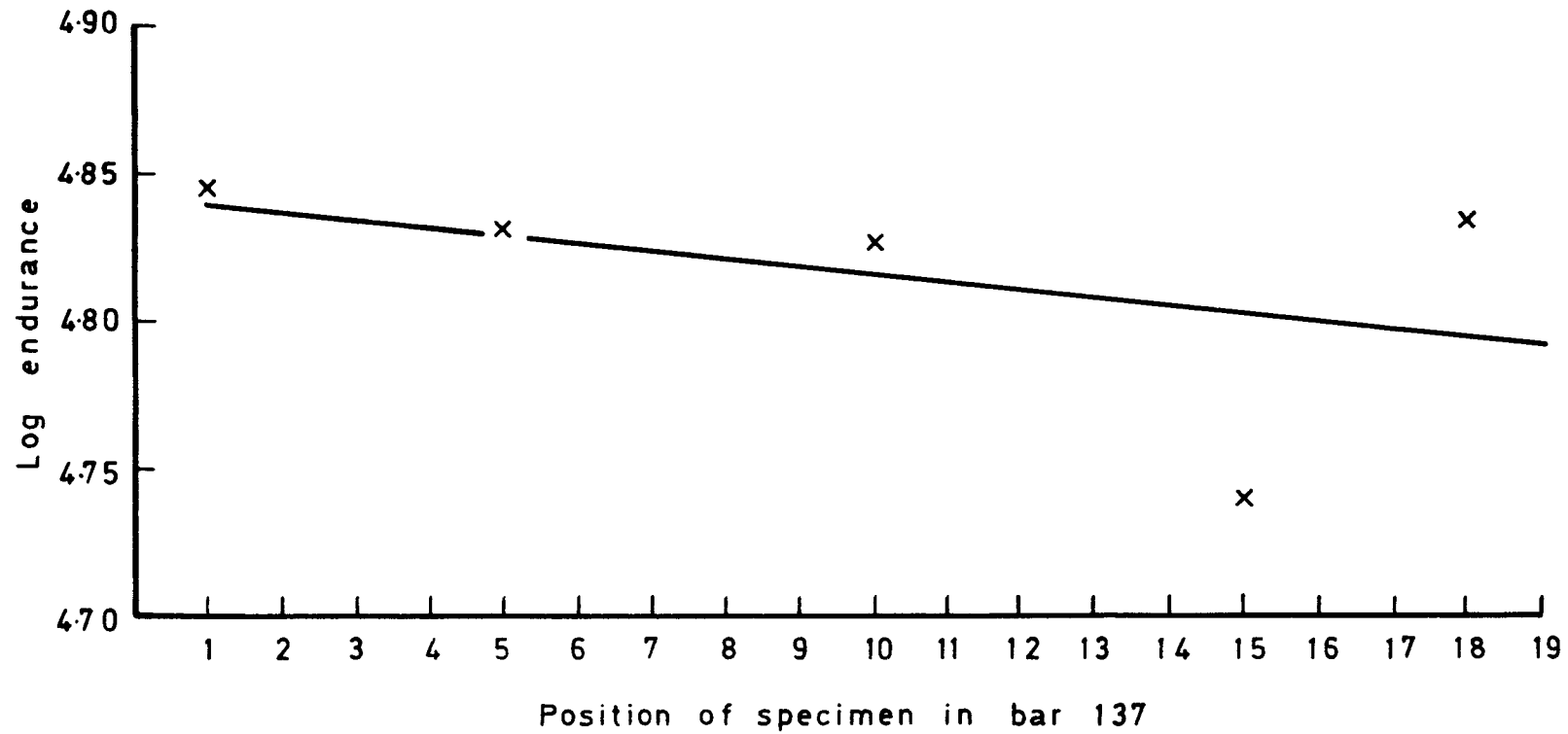

Fig. 5 Typical example of variation in fatigue endurance along bars of material

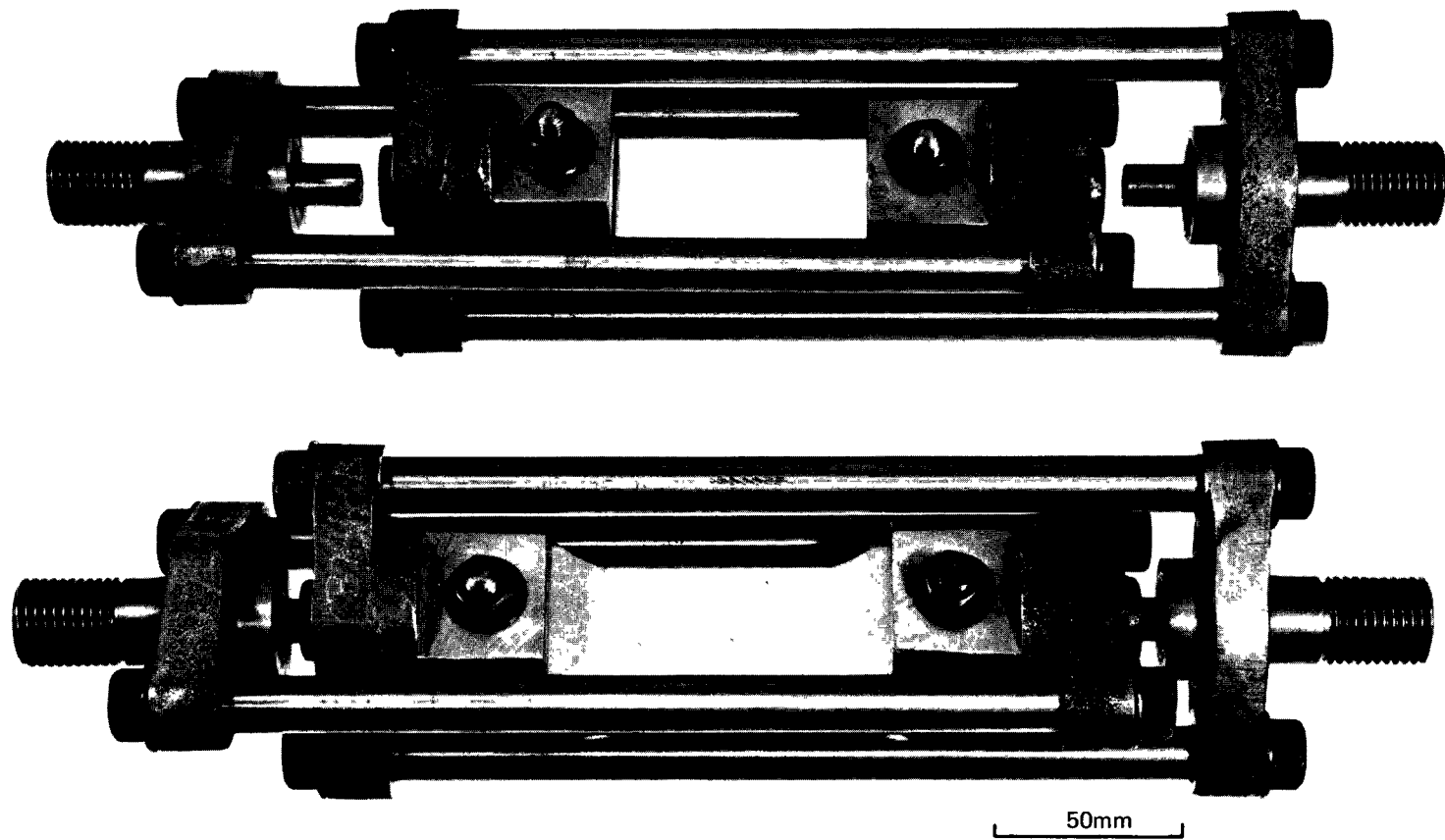

Fig.6 Compressive creep fittings

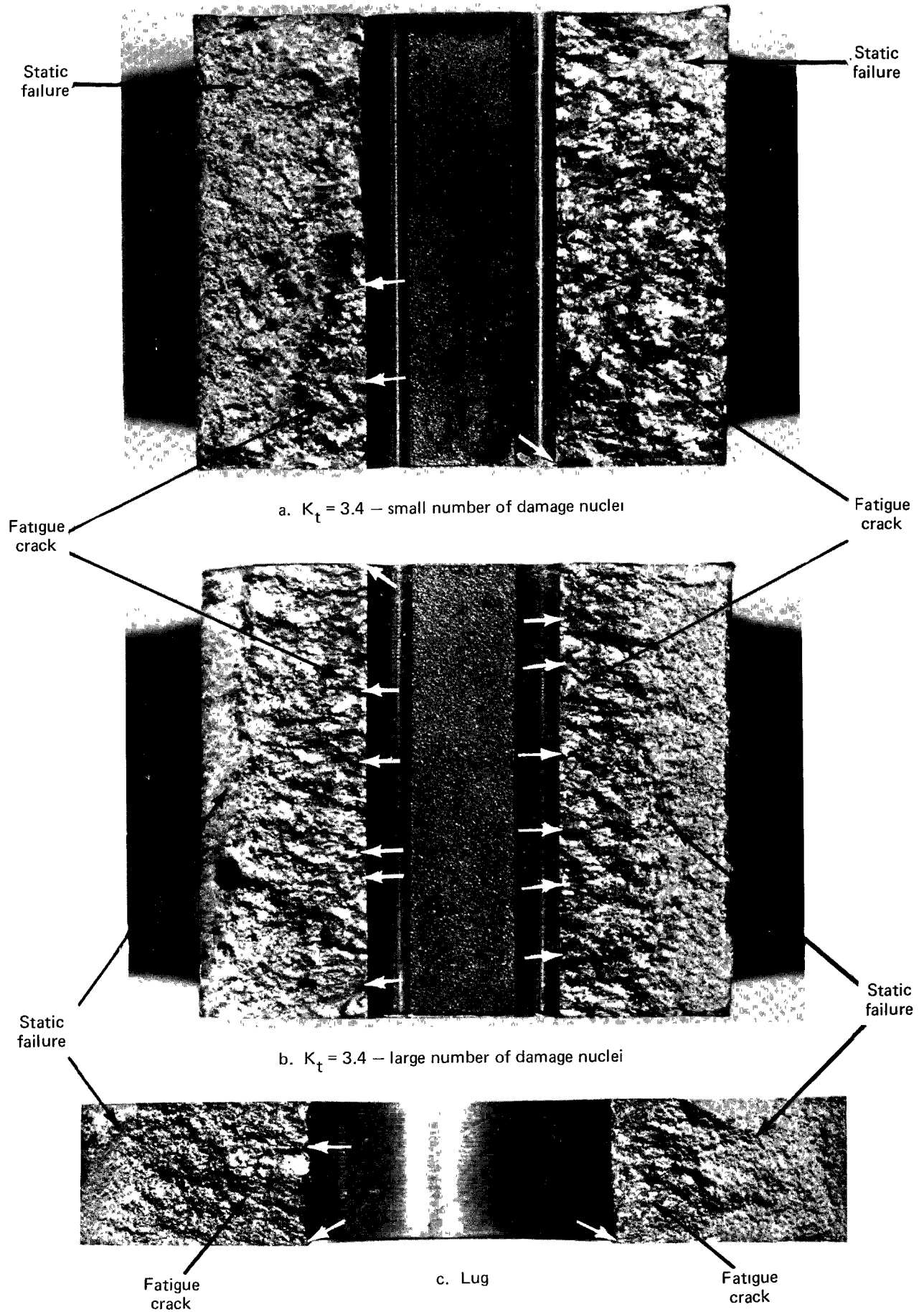

Fig.7 Appearance of fracture surfaces showing positions of damage nuclei

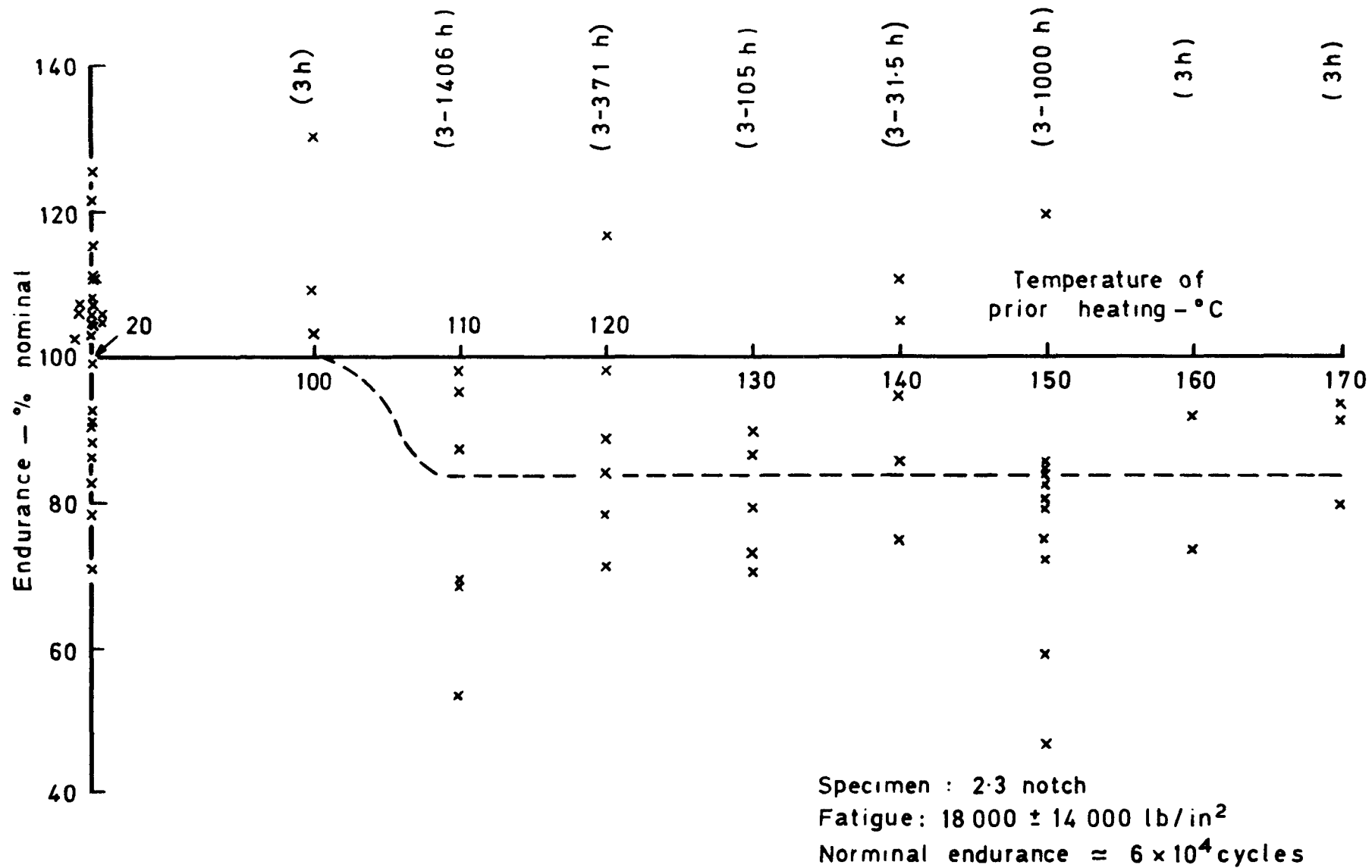

Fig. 8 Effect on endurance of temperature of prior heating - 2.3 notch specimen

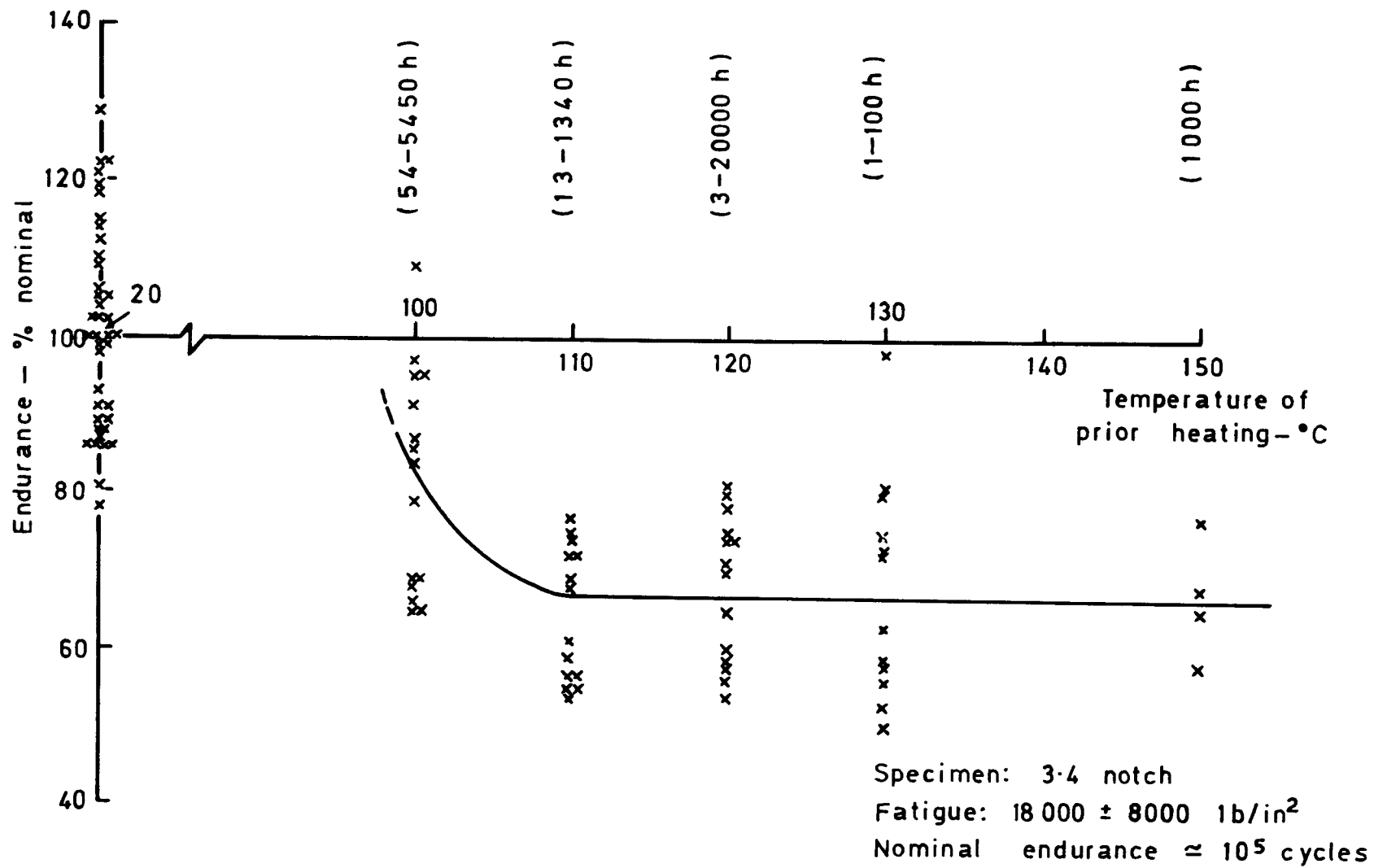

Fig.9 Effect on endurance of temperature of prior heating - 3.4 notch specimen

Specimen: 2.3 notch
Fatigue: 18 000 ± 14 000 lb/in²

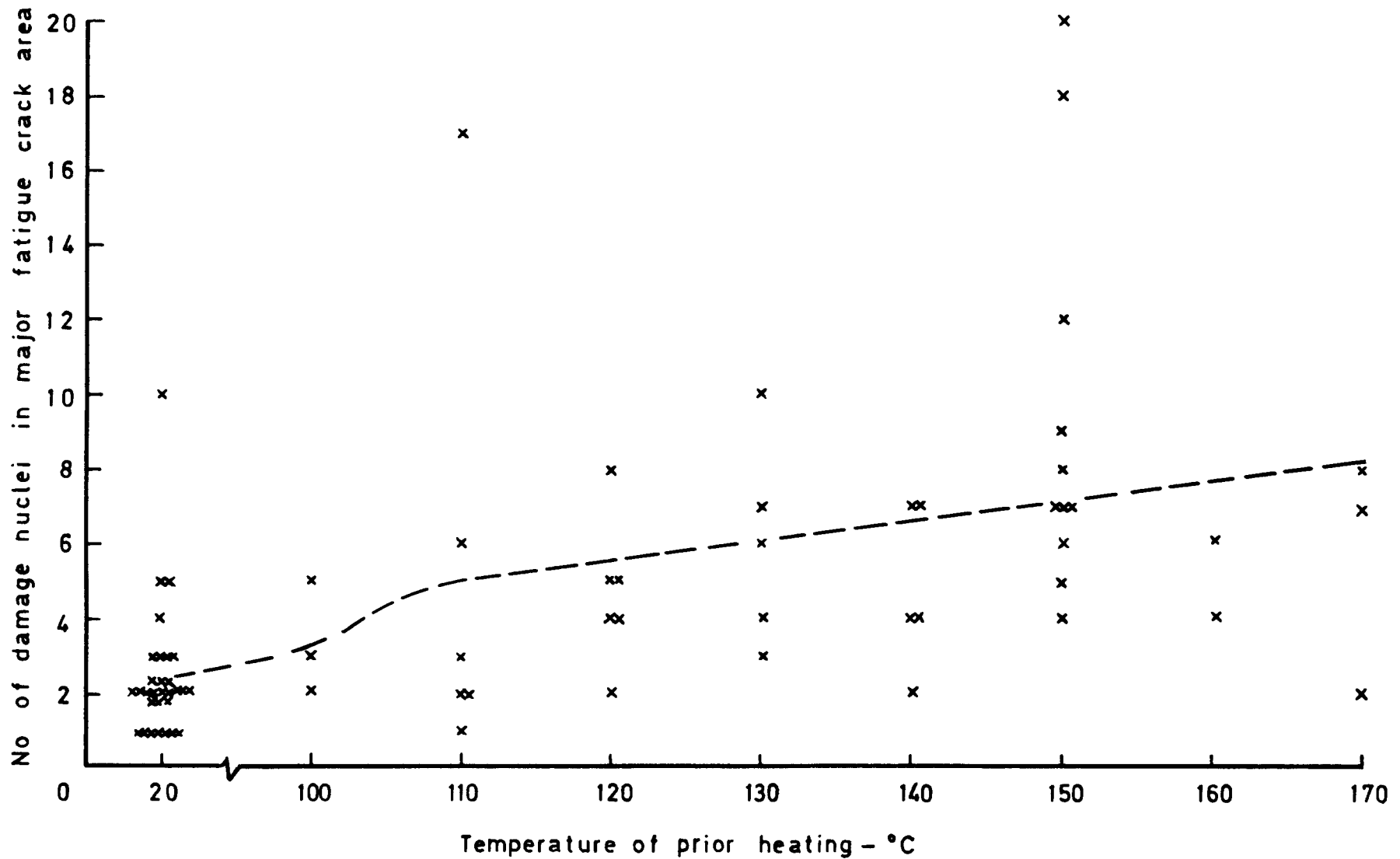

Fig. 10 Variation in number of damage nuclei with temperature of prior heating - 2.3 notch

Specimen: 3.4 notch
Fatigue: $18000 \pm 8000 \text{ lb/in}^2$

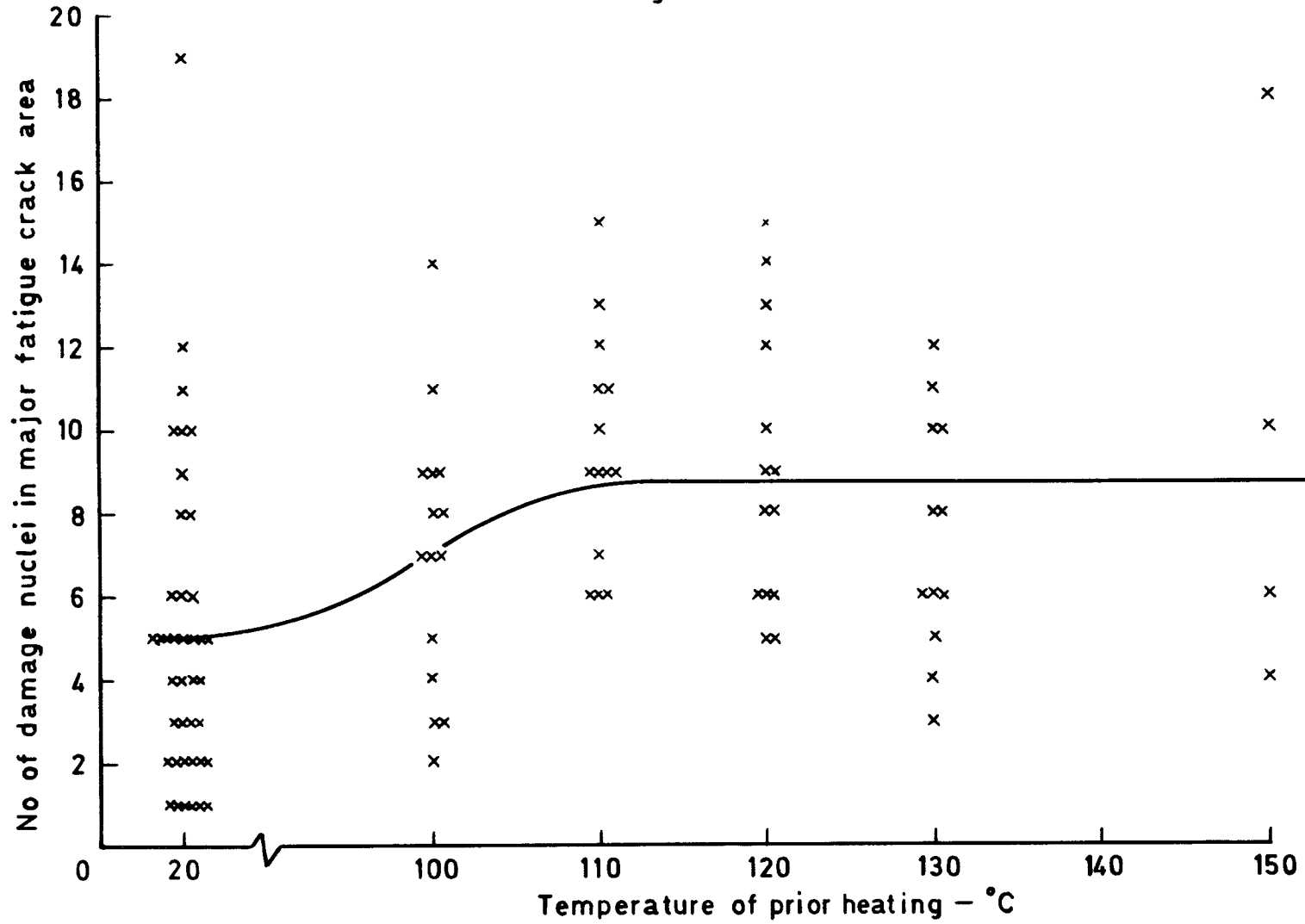

Fig.11 Variation in number of damage nuclei with temperature of prior heating - 3.4 notch

Notch $K_t = 2.3$

Fatigue stress - $18\,000 \pm 14\,000 \text{ lb/in}^2$

Nominal endurance $\approx 7 \times 10^4$ cycles

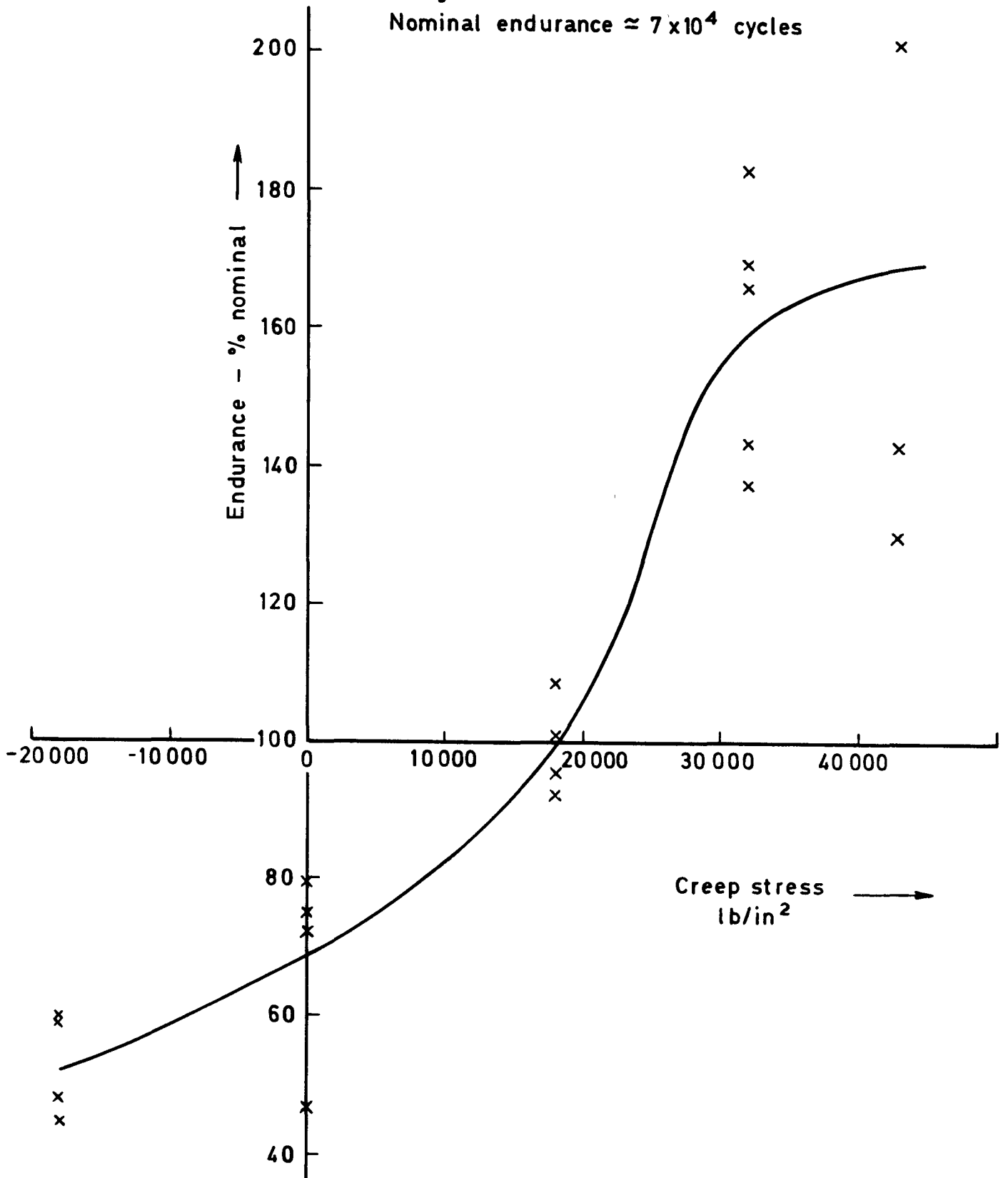

Fig.12 Effect of creep stress on fatigue endurance
-heating 3h at 150°C prior to fatigue

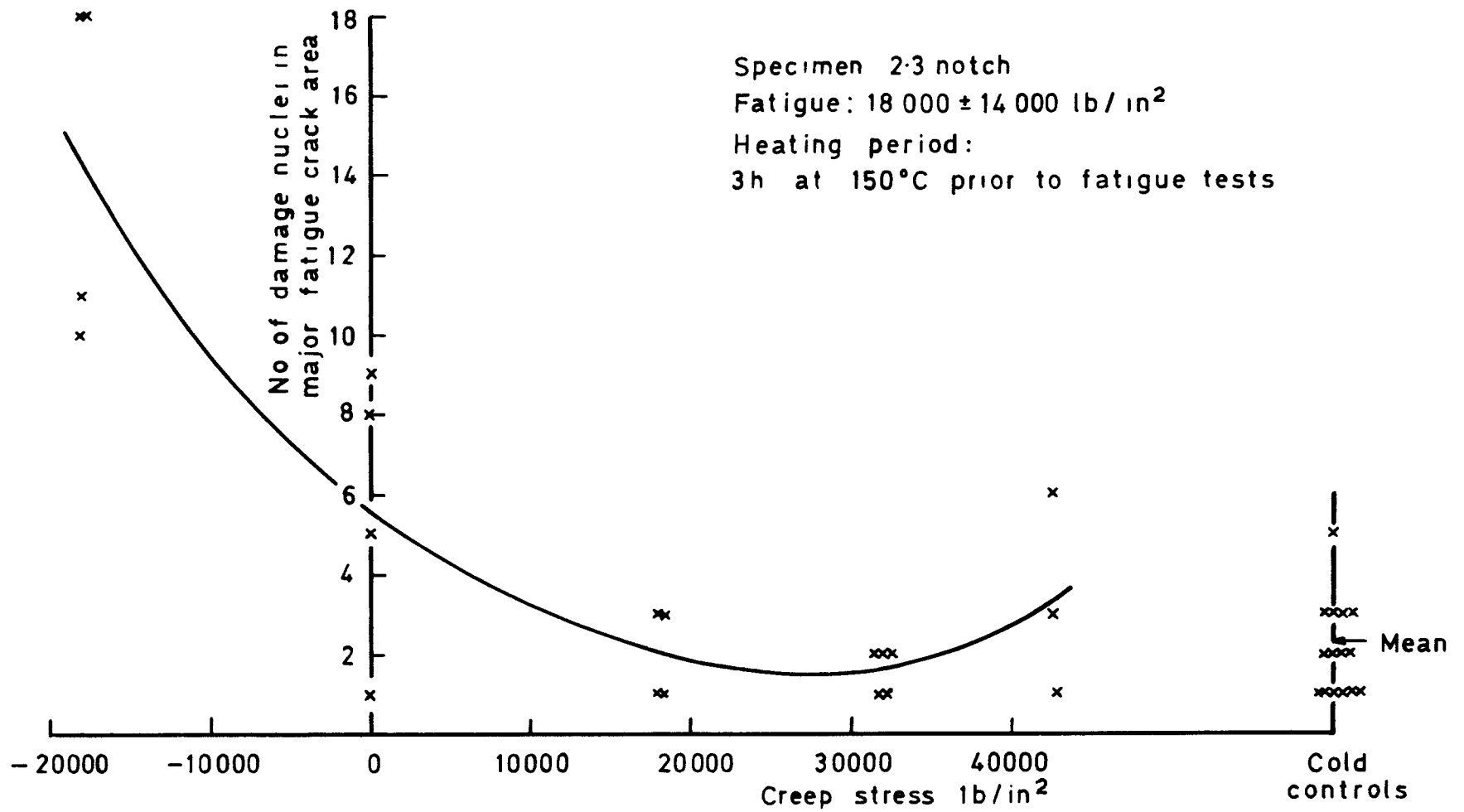

Fig.13 Variation in number of damage nuclei with creep stress — 2.3 notch

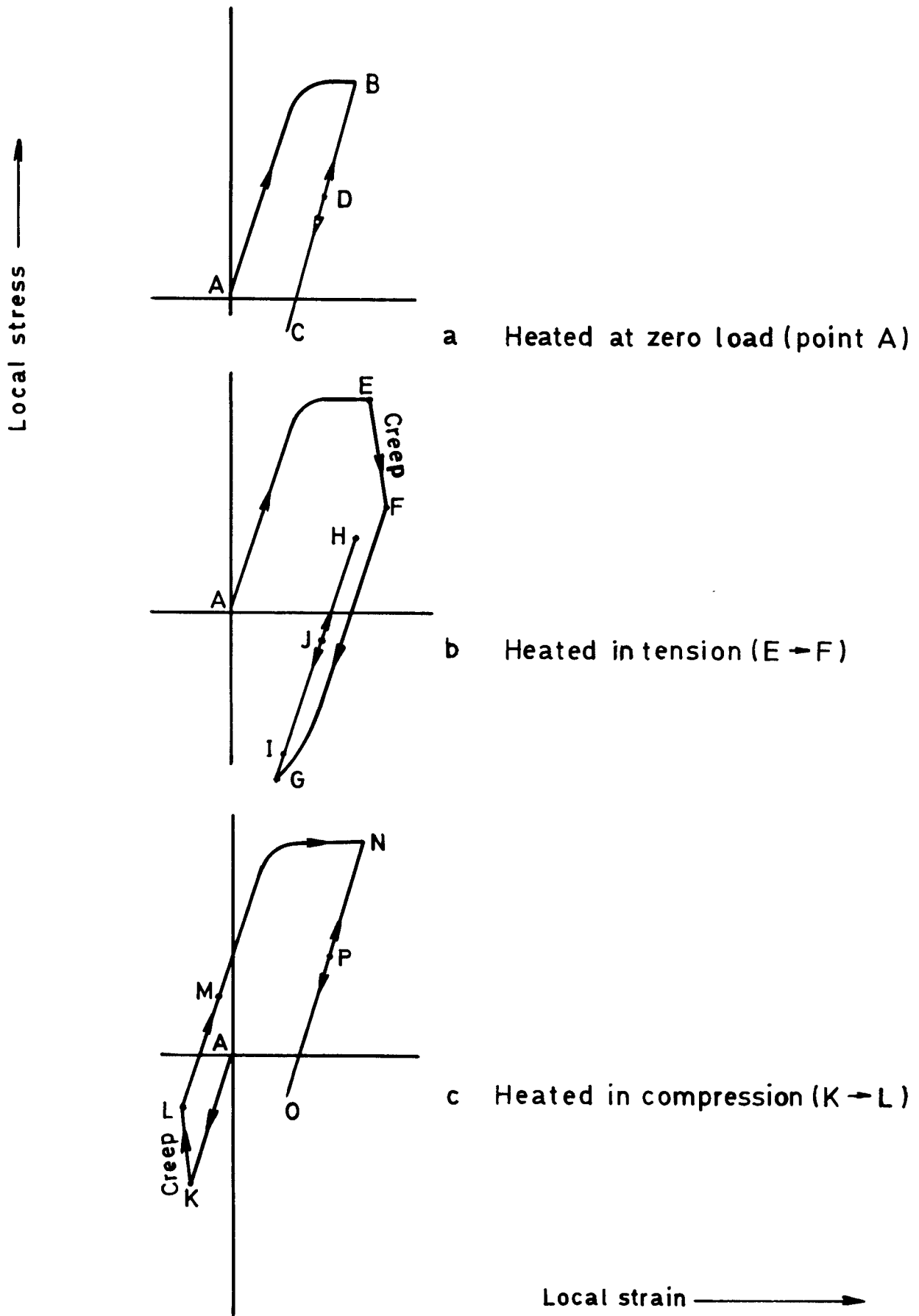

Fig.14 a-c Variation of local stress at the notch due to heating (a) At zero load, (b) in tension, and (c) in compression, followed by the application of fatigue mean stress and alternating stress

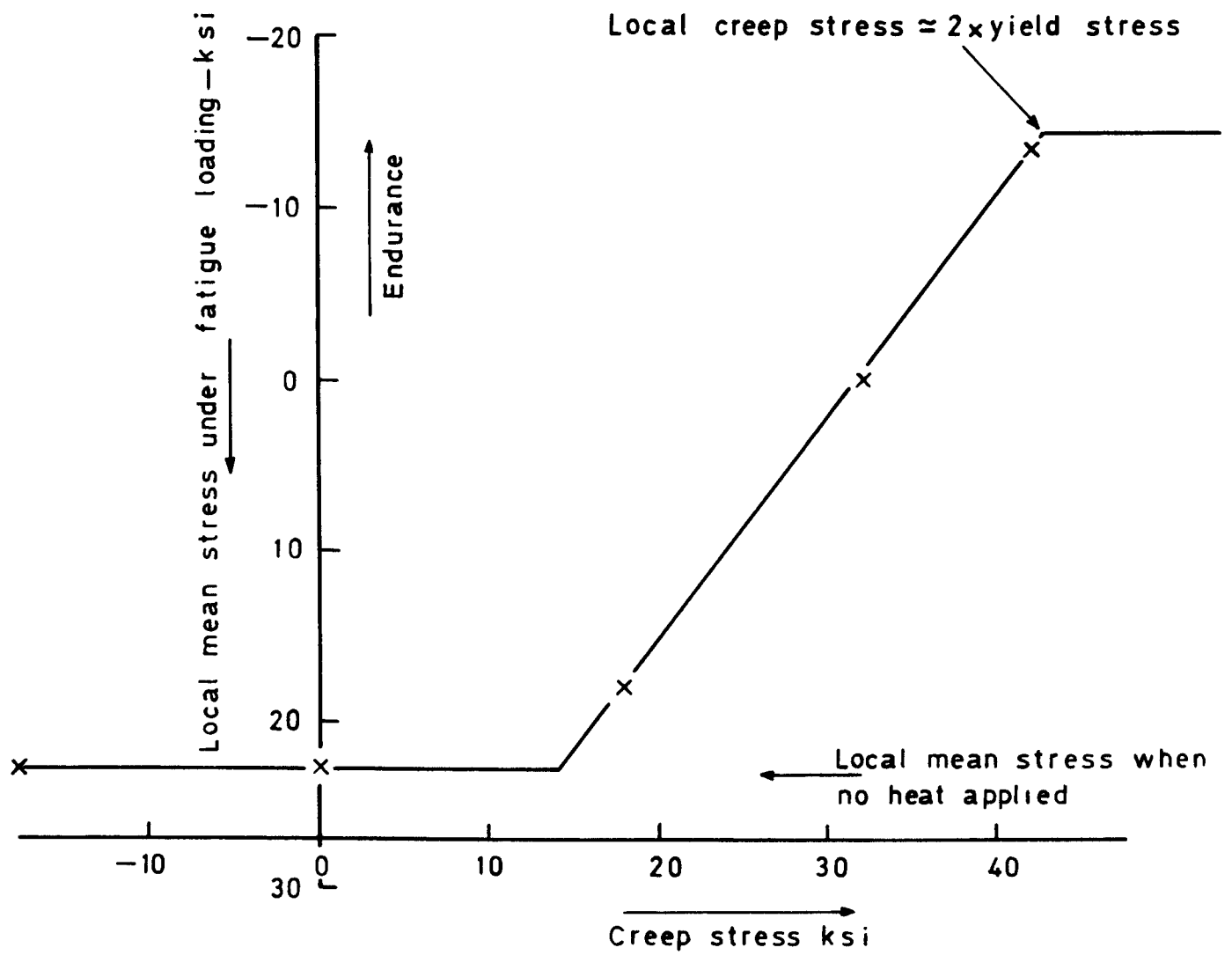

Fig.15 Variation of local mean stress at notch with applied creep stress

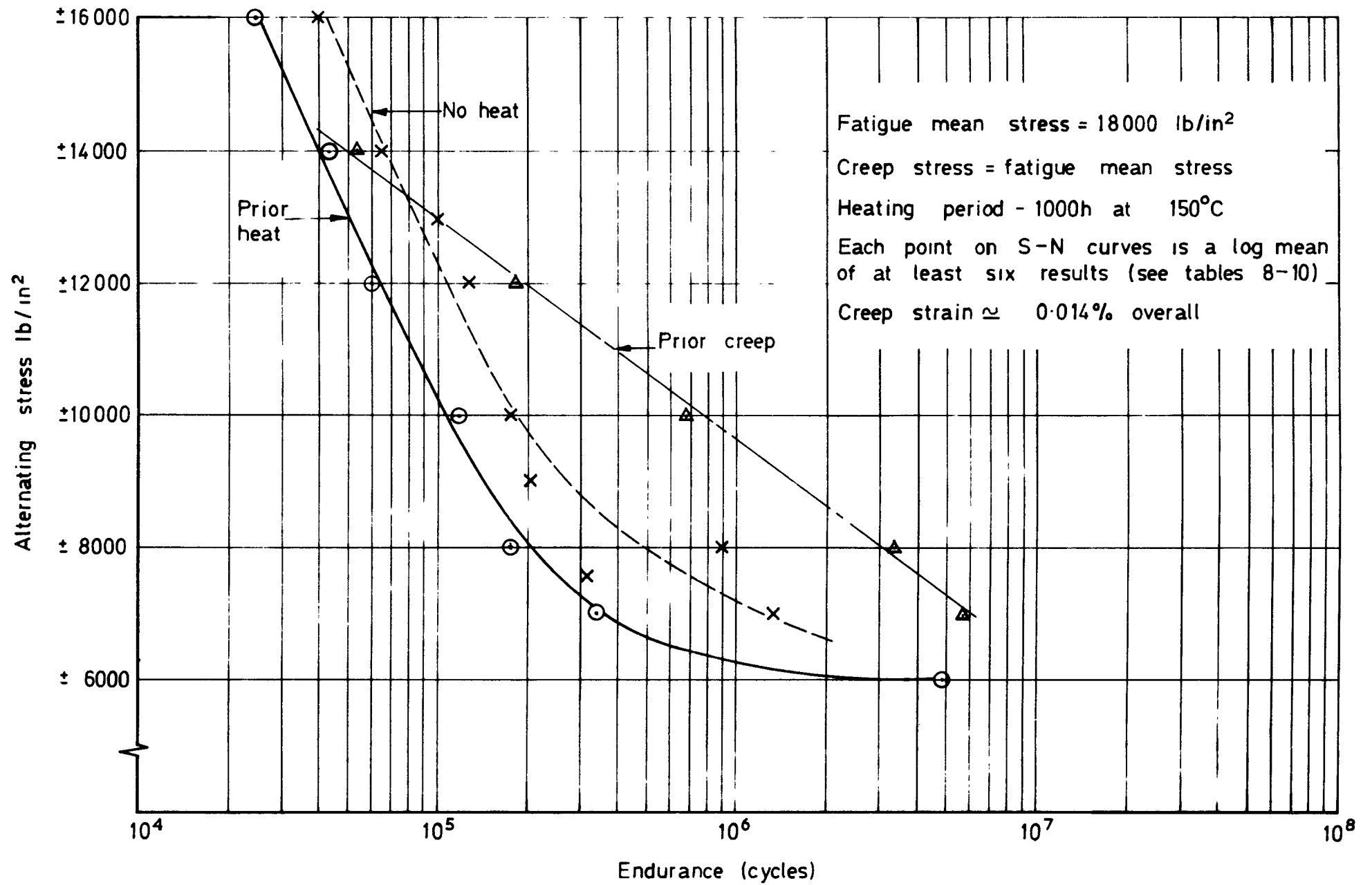

Fig.16 Effect of prior heat or creep on fatigue endurance of 2.3 notch specimens

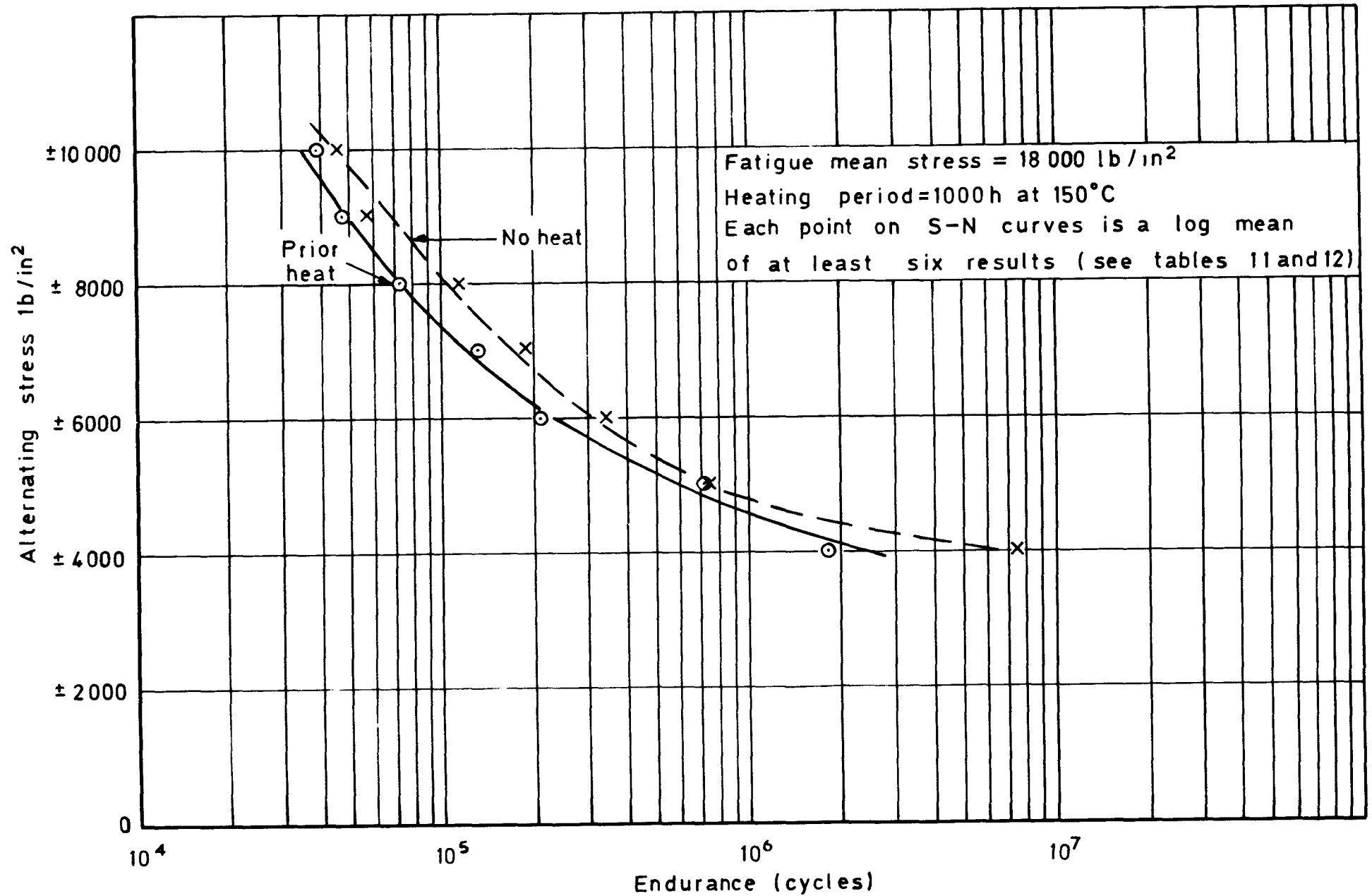

Fig.17 Effect of prior heat on endurance of 3.4 notch specimens

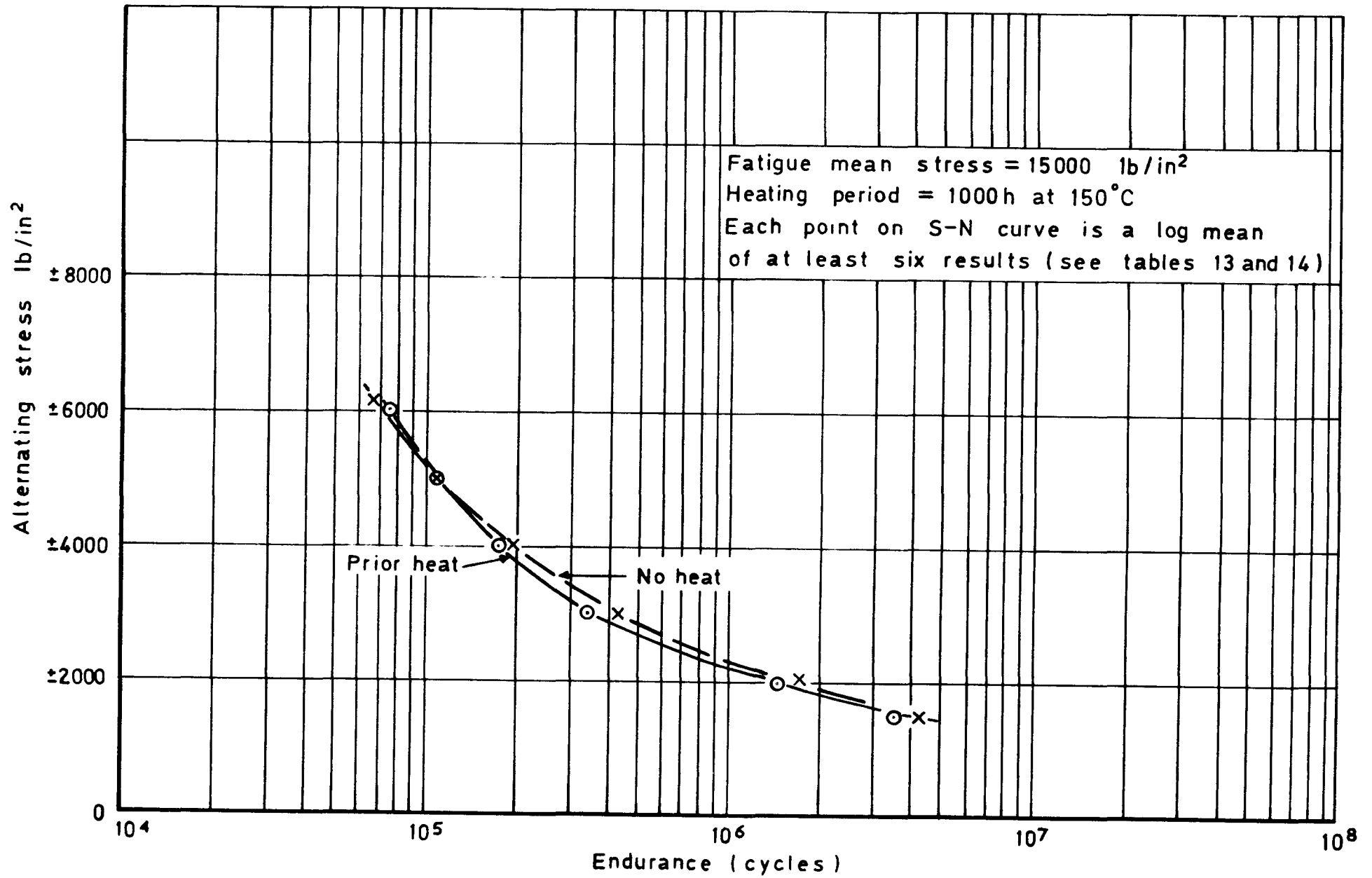

Fig. 18 Effect of prior heat on fatigue endurance of log specimens

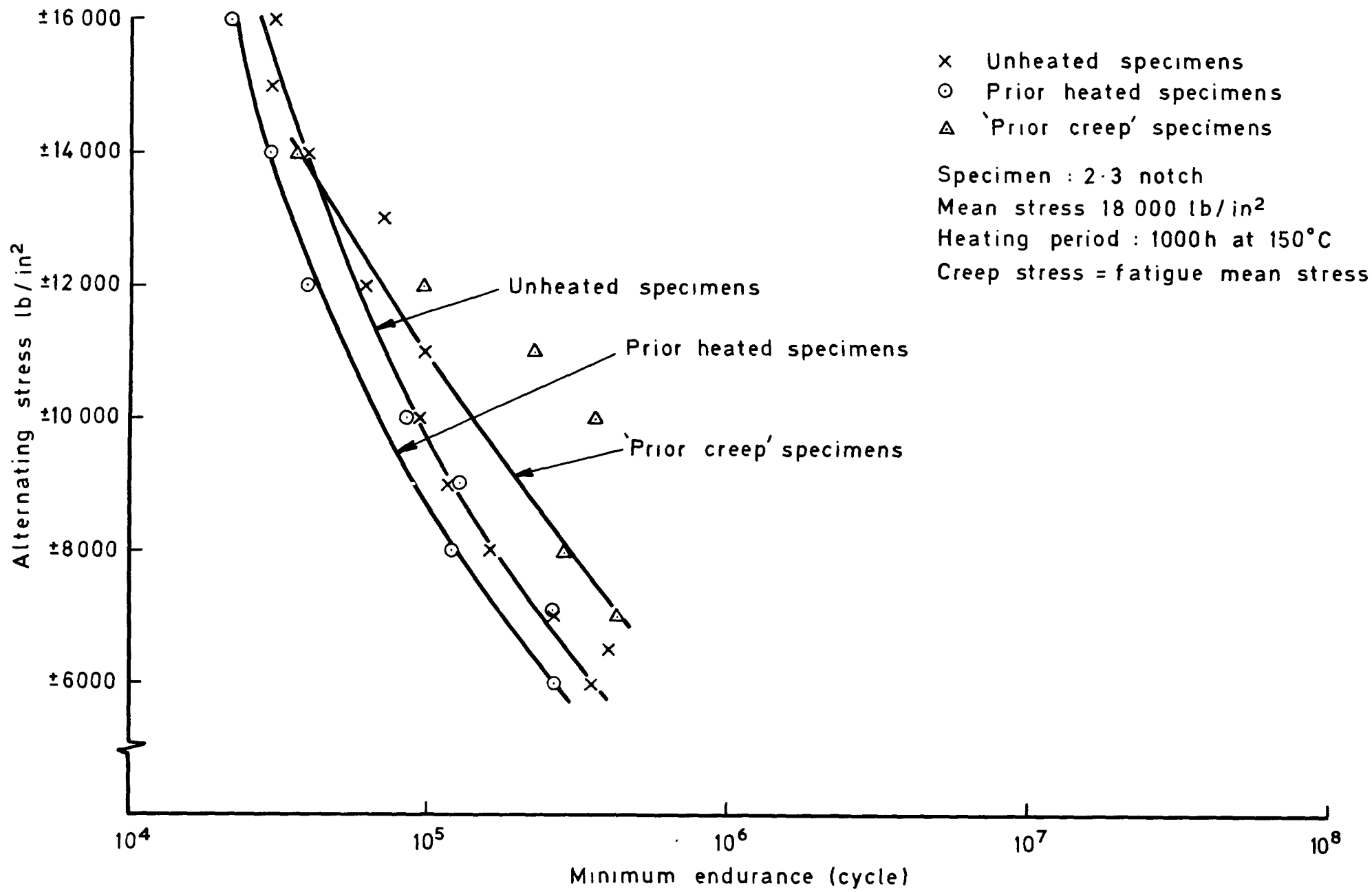

Fig.19 Effect of heat on lower boundary of S-N data for 2.3 notch specimen

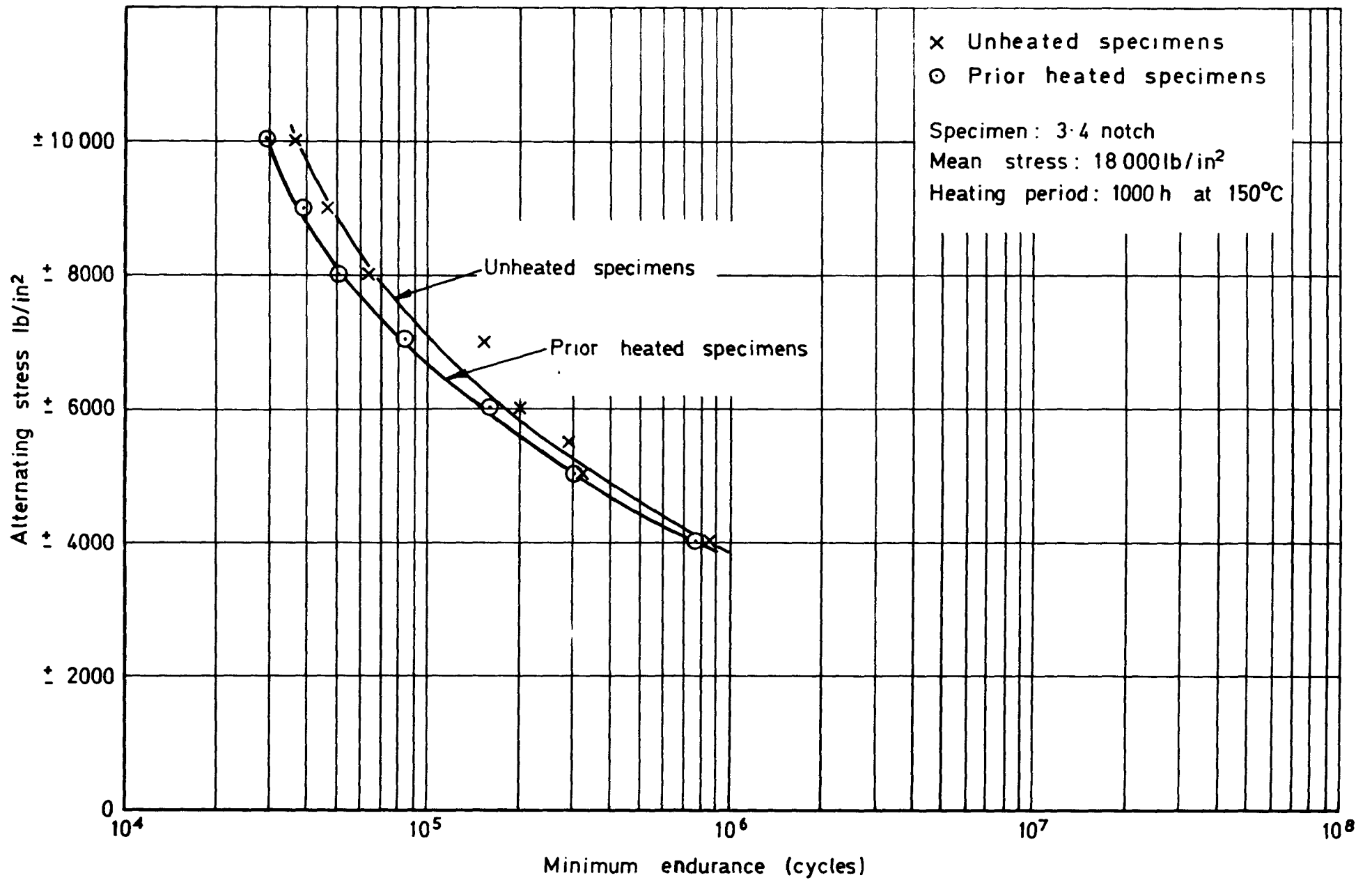

Fig. 20 Effect of heat on lower boundary of S-N data for 3.4 notch specimen

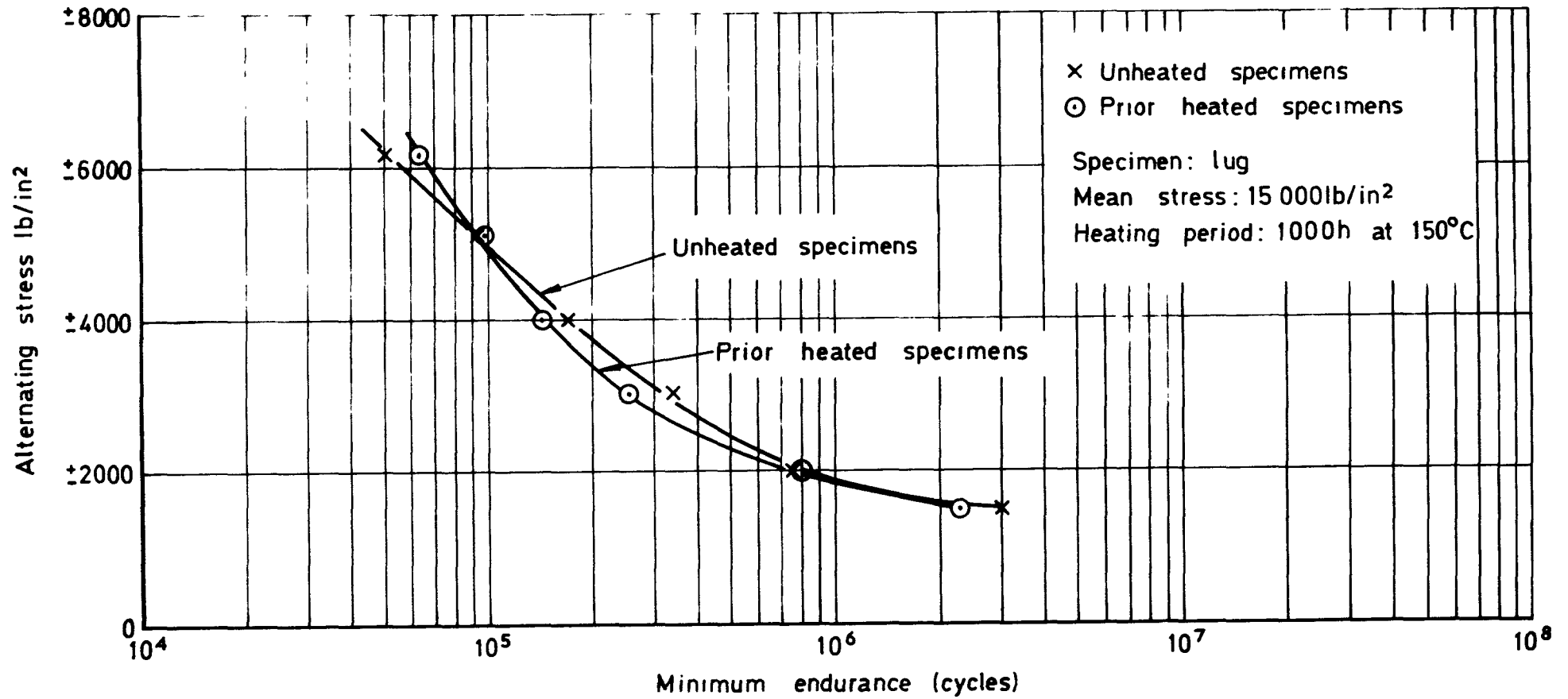

Fig. 21 Effect of heat on lower boundary of S-N data for lug specimen

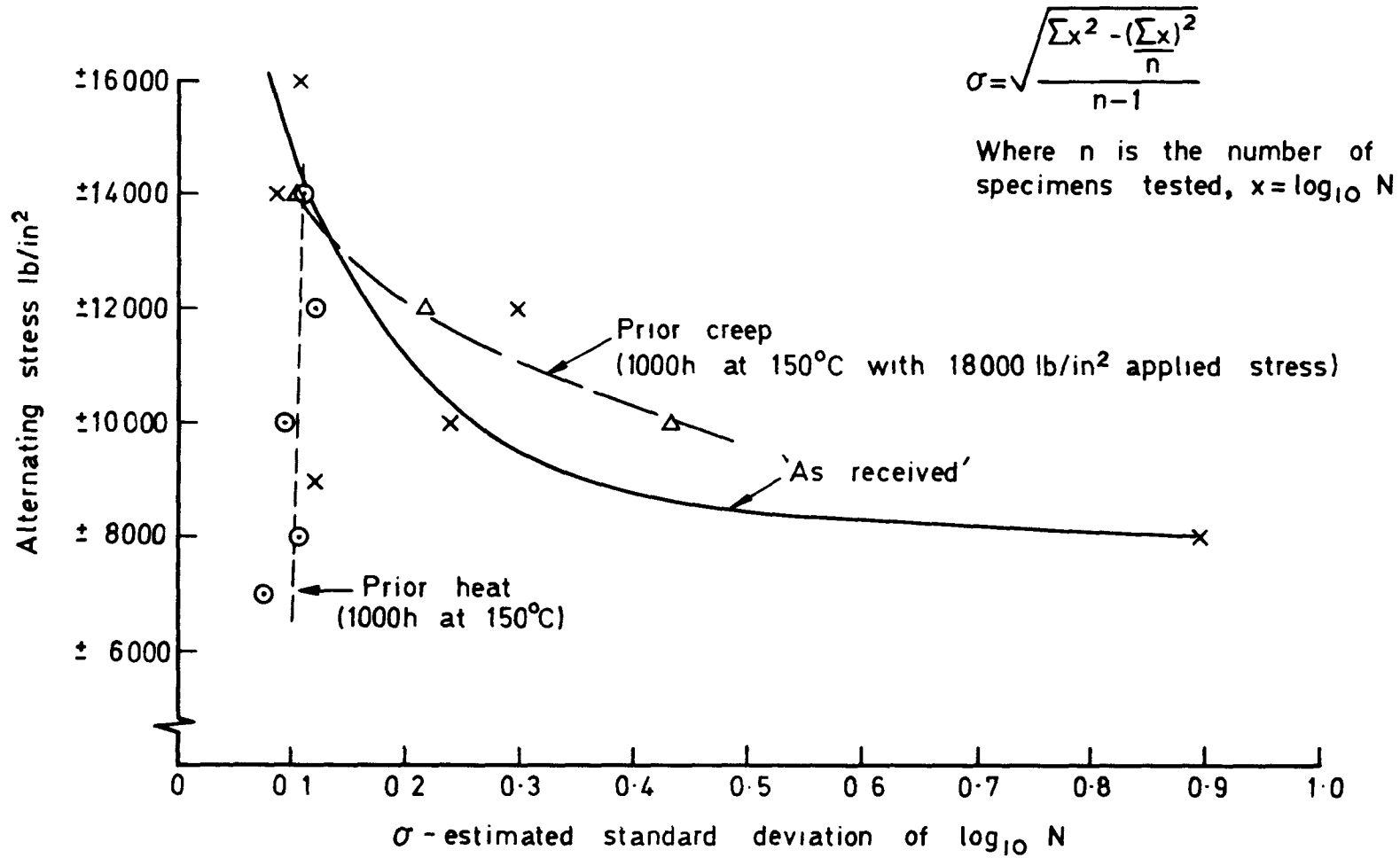
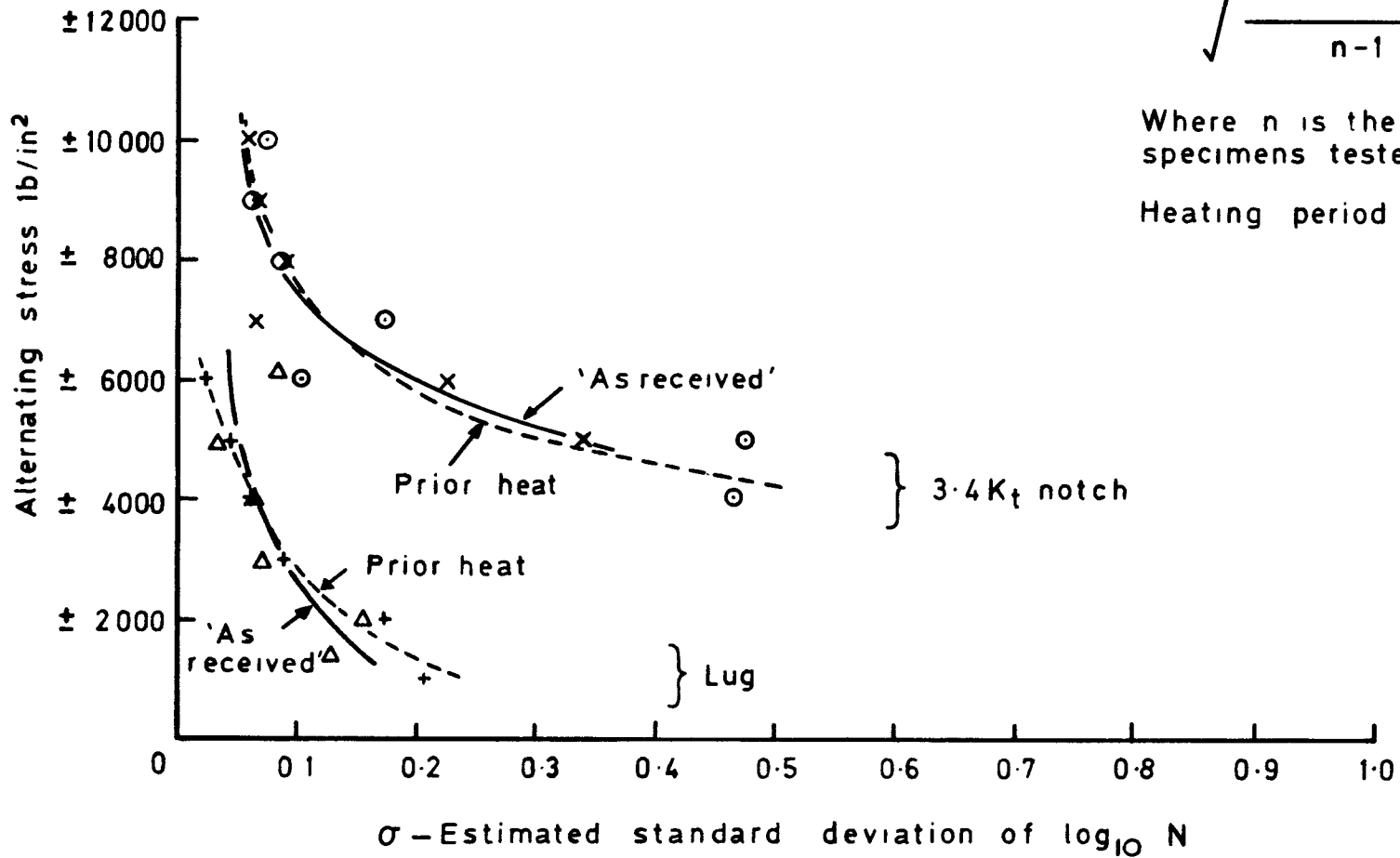

Fig.22 Variation in standard deviation with fatigue alternating stress, with or without prior heating - 2.3K_t notch specimen



$$\sigma = \sqrt{\frac{\sum x^2 - \frac{(\sum x)^2}{n}}{n-1}}$$

Where n is the number of specimens tested, x = log₁₀ N
 Heating period 1000h at 150°C

Fig. 23 Variation in standard deviation with fatigue alternating stress, with or without prior heating - 3.4K_t notch and lug specimens

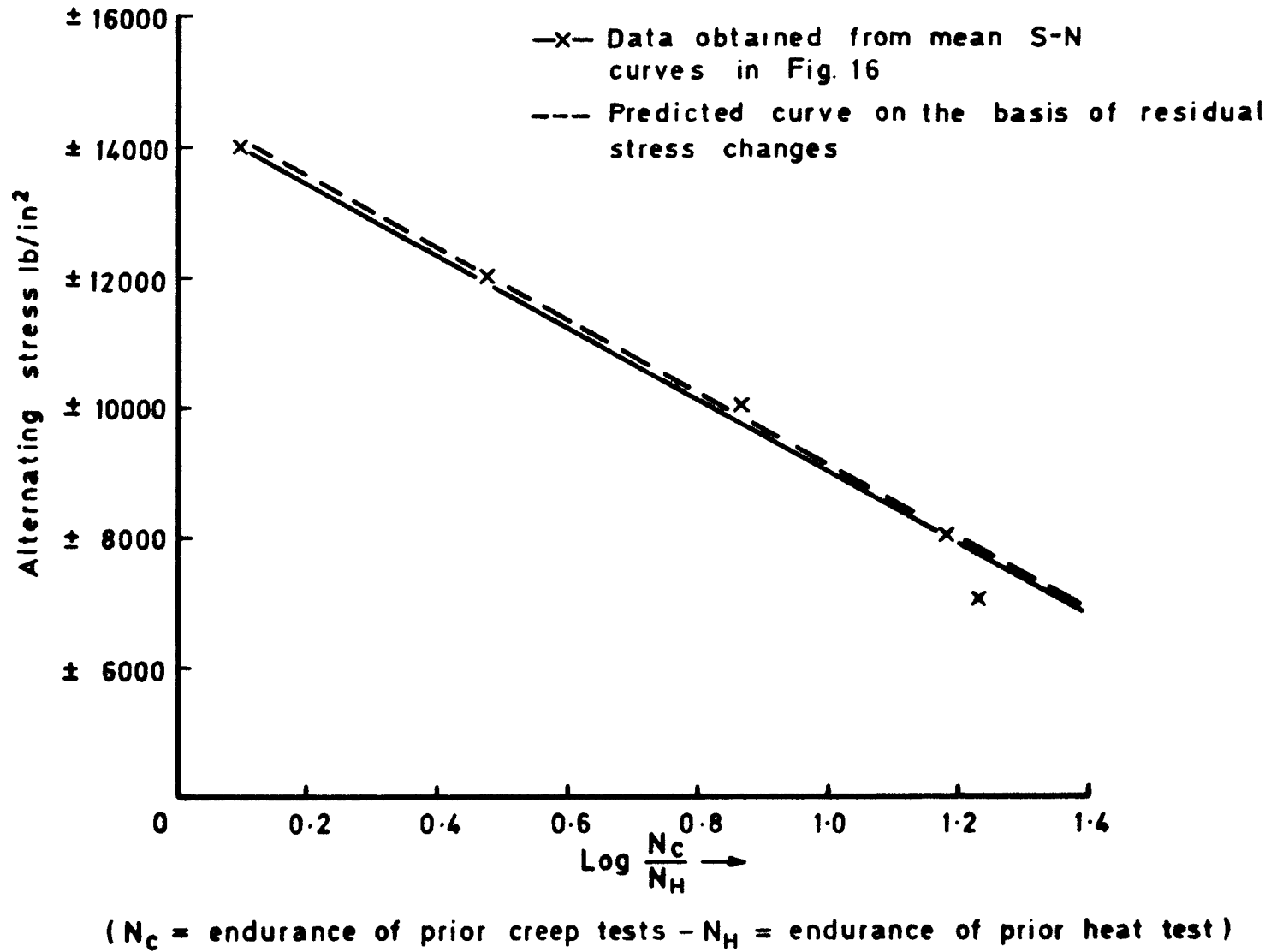

Fig.24 Variation of difference in endurance between prior creep and prior heat tests with alternating stress level

ARC CP No.1375 539.388.1 :
July 1976 539.219.2 :
539.377 :
Kiddle, F.E. 539.376 :
669.715 :
620.178.38
INFLUENCE OF PRIOR HEAT AND CREEP ON FATIGUE
IN STRUCTURAL ELEMENTS OF DTD 5014 (RR58)
ALUMINIUM ALLOY

Effects of heat on fatigue have been studied by fatigue tests at ambient temperature on specimens first subjected to a single period of heating with and without steady load applied. The tests employed constant amplitude loading on various structural elements in DTD 5014 (RR58) aluminium alloy material. Heating was applied at temperatures in the range 100°C to 170°C for times ranging from 1h to 20000h.

The initiation of fatigue cracks was significantly affected by heating, particularly at temperatures of 110°C and higher when the effects occurred comparatively rapidly. The two mechanisms of importance were changes in microstructure at the machined surface which encouraged initiation, and changes in residual stress by creep which encouraged or discouraged initiation according to the creep being compressive or tensile.

ARC CP No.1375 539.388.1 .
July 1976 539.219.2
539.377
Kiddle, F.E. 539.376
669.715
620.178.38
INFLUENCE OF PRIOR HEAT AND CREEP ON FATIGUE
IN STRUCTURAL ELEMENTS OF DTD 5014 (RR58)
ALUMINIUM ALLOY

Effects of heat on fatigue have been studied by fatigue tests at ambient temperature on specimens first subjected to a single period of heating with and without steady load applied. The tests employed constant amplitude loading on various structural elements in DTD 5014 (RR58) aluminium alloy material. Heating was applied at temperatures in the range 100°C to 170°C for times ranging from 1h to 20000h.

The initiation of fatigue cracks was significantly affected by heating, particularly at temperatures of 110°C and higher when the effects occurred comparatively rapidly. The two mechanisms of importance were changes in microstructure at the machined surface which encouraged initiation, and changes in residual stress by creep which encouraged or discouraged initiation according to the creep being compressive or tensile.

DETACHABLE ABSTRACT CARDS

ARC CP No.1375 539.388.1 :
July 1976 539.219.2 :
539.377 :
Kiddle, F E 539.376 :
669.715 :
620.178.38
INFLUENCE OF PRIOR HEAT AND CREEP ON FATIGUE
IN STRUCTURAL ELEMENTS OF DTD 5014 (RR58)
ALUMINIUM ALLOY

Effects of heat on fatigue have been studied by fatigue tests at ambient temperature on specimens first subjected to a single period of heating with and without steady load applied. The tests employed constant amplitude loading on various structural elements in DTD 5014 (RR58) aluminium alloy material. Heating was applied at temperatures in the range 100°C to 170°C for times ranging from 1h to 20000h.

The initiation of fatigue cracks was significantly affected by heating, particularly at temperatures of 110°C and higher when the effects occurred comparatively rapidly. The two mechanisms of importance were changes in microstructure at the machined surface which encouraged initiation, and changes in residual stress by creep which encouraged or discouraged initiation according to the creep being compressive or tensile.

ARC CP No.1375 539.388.1
July 1976 539.219.2
539.377 :
Kiddle, F.E. 539.376 :
669.715 :
620.178.38
INFLUENCE OF PRIOR HEAT AND CREEP ON FATIGUE
IN STRUCTURAL ELEMENTS OF DTD 5014 (RR58)
ALUMINIUM ALLOY

Effects of heat on fatigue have been studied by fatigue tests at ambient temperature on specimens first subjected to a single period of heating with and without steady load applied. The tests employed constant amplitude loading on various structural elements in DTD 5014 (RR58) aluminium alloy material. Heating was applied at temperatures in the range 100°C to 170°C for times ranging from 1h to 20000h

The initiation of fatigue cracks was significantly affected by heating, particularly at temperatures of 110°C and higher when the effects occurred comparatively rapidly. The two mechanisms of importance were changes in microstructure at the machined surface which encouraged initiation, and changes in residual stress by creep which encouraged or discouraged initiation according to the creep being compressive or tensile.

DETACHABLE ABSTRACT CARDS

Cut here

Cut here

© *Crown copyright*

1977

Published by
HER MAJESTY'S STATIONERY OFFICE

Government Bookshops

49 High Holborn, London WC1V 6HB

13a Castle Street, Edinburgh EH2 3AR

41 The Hayes, Cardiff CF1 1JW

Brazennose Street, Manchester M60 8AS

Southey House, Wine Street, Bristol BS1 2BQ

258 Broad Street, Birmingham B1 2HE

80 Chichester Street, Belfast BT1 4JY

*Government Publications are also available
through booksellers*