



MINISTRY OF TECHNOLOGY

AERONAUTICAL RESEARCH COUNCIL

CURRENT PAPERS

ROYAL AIRCRAFT ESTABLISHMENT
BEDFORD.

A Note on some Static Tests of Flexible Skirts for Hovercraft

by

W. G. S. Lester and F. T. Kiernan

LONDON: HER MAJESTY'S STATIONERY OFFICE

1968

PRICE 7s 6d NET

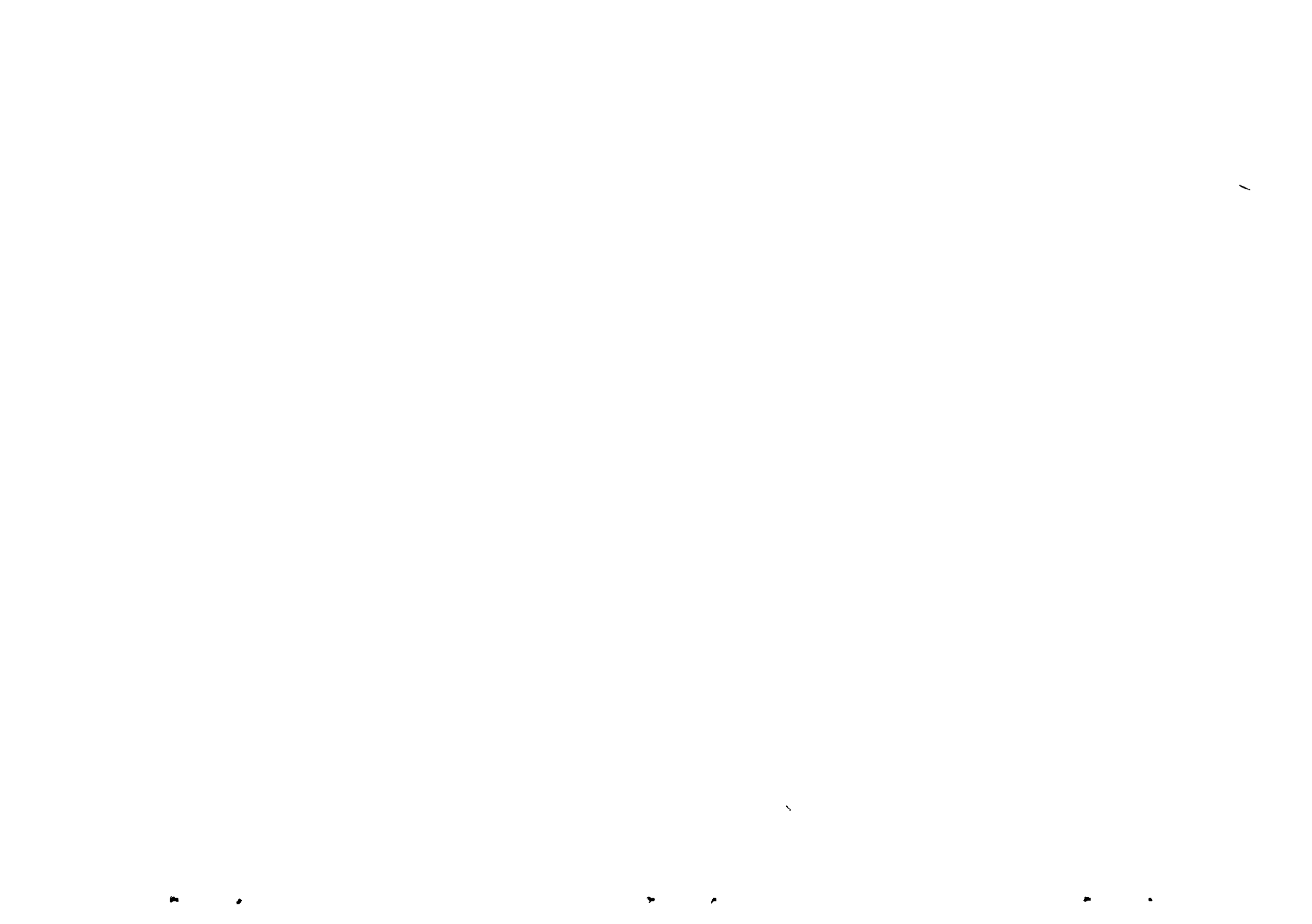

A NOTE ON SOME STATIC TESTS OF FLEXIBLE SKIRTS FOR HOVERCRAFT

by

W. G. S. Lester

F. T. Kiernan

SUMMARY

A series of static tests conducted to establish an efficient form of flexible skirt for a peripheral jet type of hovercraft is reported. The importance of designing the peripheral jet system in conjunction with the skirt is demonstrated. The results suggest that the effective width of a flexible nozzle is less than its actual width and the discharge coefficient requires determining experimentally for each configuration. It is concluded that skirt configuration performance is best compared on the basis of power input to a skirt to generate a given cushion pressure for a specified daylight clearance. The results confirm that the skirt input power per unit exit area, based on daylight clearance and jet length, is directly proportional to (cushion pressure)^{3/2}.

* Replaces R.A.E. Technical Report 66053 - A.R.C. 29356

CONTENTS

	<u>Page</u>
1 INTRODUCTION	3
2 THE TEST RIG	5
3 PRELIMINARY TESTS	7
4 THE DEVELOPMENT OF AN EFFICIENT SKIRT	10
5 COMPARISON BETWEEN THEORY AND EXPERIMENT	11
6 EXPERIMENTAL RESULTS	12
7 TESTS WITH A NON-VERTICAL SKIRT FEED SLOT	14
8 CONCLUSIONS	15
Reference	17
Illustrations	Figures 1-17
Detachable abstract cards	-

1 INTRODUCTION

In recent years interest has been shown in the possibility of improving the overland and overwater capability of hovercraft. It has now become apparent that a considerable improvement in performance can be achieved by fitting hovercraft with flexible extensions to the hull; these extensions or skirts are capable of being deflected whilst passing over an obstacle and then, by virtue of the cushion pressure and the airflow through the skirt, return to their design configuration. With the original hovercraft conception of a completely rigid hulled craft the maximum obstacle height which could be cleared was governed by the hover height of the craft and useful practical clearances demanded excessive power; the provision of a flexible skirt has meant that hover heights can be minimised and it is no longer necessary to install power sufficient to give a daylight clearance equal to the maximum height of obstacle likely to be encountered. The terms daylight clearance, ground clearance and hover height are strictly synonymous but the first is used generally in this Report since the others are sometimes used to indicate the distance between the ground and the lower portion of the hard structure of the hovercraft rather than that of the flexible skirt. For a craft fitted with flexible skirts the daylight clearance beneath the skirt need only be sufficient to ensure that the majority of small surface irregularities are passed over without contact and larger obstacles are accommodated by the skirt flexibility; a reasonable daylight clearance is desirable in order to minimise skirt wear. The maximum height of obstacle which can be accommodated is ideally the length of the flexible extension below the rigid portion of the hull plus the maximum daylight clearance of the craft; in practice this is not achieved because skirt flexibility does not extend over the whole length of skirt and the skirt becomes stiffer towards the hull attachment, making deflection more difficult and reducing the effective skirt length.

The usual skirt system employed on a peripheral jet craft consists of a double-walled skirt enclosing the peripheral jet and forming a new exit nozzle through which the air supply is fed to form the air cushion beneath the craft. In addition, if the basic craft uses an array of longitudinal and transverse jets for assisting in maintaining stability, or contributing to propulsion and control, these are also fitted with double walled skirts in an attempt to retain the original functions of the jets. The bow skirts have to be designed so that they can be deflected inwards on contact with an obstacle; the aft skirts so that they can be deflected outwards to permit egress of the obstacle.

and the side skirts and longitudinal stability skirts so that they can be deflected aft. In design allowance must be made for these three different directions of deflection and provision also made for contact with obstacles met whilst the craft is yawing or side-slipping. The aft skirt is usually split into sections to facilitate obstacle egress and prevent scooping up of debris; to some extent this eliminates the necessity for rearward deflection of the aft skirts. In some cases closed inflated bags have been used instead of an aft skirt on craft with low daylight clearance and a tendency to scooping.

There are many practical problems associated with the design of flexible skirts; the skirt shape and nozzle design must be such that severe flow losses are not induced or control and stability of the craft impeded; the skirt length must allow a reasonable obstacle clearing capability without raising the centre of gravity of the craft to a height where instability becomes manifest; a robust though flexible construction is required, and the materials used must have a high resistance to tear, abrasion and exposure to atmospheric conditions to ensure a useful working life. The addition of a skirt to a hovercraft will reduce the daylight clearance if the same payload is to be carried as on an unmodified craft: to minimise this reduction the weight of the skirt and its attachments must be low but consistent with durability. Skirts have to some extent been regarded as ancillary items to be added to a completed craft and designed separately; this is an unfortunate situation for the skirt should be an integral part of the craft and the ducting from the fan to the skirt designed in conjunction with the skirt for maximum efficiency. A vertical discharge from the fan into the skirt is desirable whereas for a craft without skirts the peripheral jet is usually inclined inwards for maximum efficiency and the ducting designed accordingly. The skirt is effectively a continuation of the ducting in the rigid hull and terminates in a nozzle discharging air at an angle to the ground. To maintain the design shape of this nozzle the skirt contours are determined by fabric diaphragms; in some cases it is possible to replace these diaphragms by string ties but, in general, the strings vibrate and cause flutter of the skirt assembly. The saving in weight through using string ties is appreciable and the construction is also easier. The presence of the skirt always leads to an increase in flow energy losses which can be minimised by correct nozzle and ducting design and limitation of the number of disturbance generating items, such as diaphragms, within the skirt. Diaphragms are however a disadvantage in that they impede the propulsion facility provided by the longitudinal jet systems of some craft and prevent control of the direction of the jet thrust; the effectiveness of moveable vanes in the rigid ducting of the craft is also impaired and there is a need for a skirt control system.

The present note is concerned with the results of static tests on various forms of fabric skirt. The object has been to assess the practicability of different skirt designs; to find the extent to which the design shape of a flexible nozzle is maintained, and to determine a form of skirt which does not induce high flow losses. Little research appears to have been done on the theoretical aspects of nozzle design for skirt application and even the optimum jet discharge angle for a peripheral jet craft is a matter for conjecture: some designers favour a jet making an angle of 60° with the ground and others use angles of 45° or less. But, with a flexible fabric nozzle, the jet angle must change where the skirt is deflected by an obstacle and variations in the lift and stability of the craft will occur; this aspect can only be examined by full scale trials with a hovercraft and the skirt designer can only ensure that the nozzle provides a consistent jet angle when there is complete daylight clearance.

The practical aim of the tests has been to produce flexible extensions for the Britten-Norman Cushioncraft CC-2 of Naval Air Department at R.A.E. Bedford and scale dimensions of the skirts tested and the cushion pressures involved have been directly related to this craft. The peripheral jet of this particular craft is directed vertically downwards for feeding the skirt assembly but some tests have been conducted using the original hull form with the jet discharging at an angle of 30° to the underside of the hull. Much of the practical knowledge gained is however directly applicable to flexible skirts and nozzles in general.

Sufficient results have now been obtained for a preliminary report to be made; the results and conclusions are by no means final but a better understanding of the problems associated with the design of flexible skirts is slowly being achieved. Many of the experiments made have been negative or inconclusive and the test rig has suffered from a range of teething problems. Fundamental work on the aerodynamics of nozzle design is required but this is a long term project and practical developments are more urgent; the current programme thus consists largely of a number of 'ad hoc' experiments to determine a skirt with a reasonable performance.

The experiments recorded in this Report were conducted as part of the research programme at R. & D.E. Cardington.

2 THE TEST RIG

A very simple rig was constructed initially for the testing of sample skirts. This rig was designed to accommodate straight skirt sections of 3 ft

breadth and variable length up to approximately 16 in. The hull of the hovercraft was simulated by a closed rectangular wooden box enclosing a fairing representing the hull section; a rectangular slot 3 ft long and variable in width from 2 in to 10 in was cut in the base of the box to form the peripheral jet orifice. A moulding was fitted on the inner jet edge interior to the box to simulate the ducting of the flow into a vertical jet stream as in the hovercraft. The base of each skirt sample was attached to a rectangular framework which could be clamped to the underside of the box so as to surround the jet orifice. A circular orifice, 8 in in diameter, was cut in the rear of the box and the air supply from a small blower was directed through this to discharge from the peripheral jet into the test skirt and out via the flexible jet nozzle. The blower used was capable of delivering about 2000 cu ft/min at a pressure of up to 8 in water gauge and its output was controlled by means of a butterfly throttle valve. The wooden box was mounted on top of an open fronted cage with walls of perspex; the region interior to this cage and behind the skirt retained the air cushion formed as a result of the discharge from the nozzle. Soft foam rubber was used between the side walls of the cage and the end caps of the skirt section to prevent loss of cushion pressure. The cage was fitted with a wooden floor adjustable in height using small jacks to give a continuous range of daylight clearances between the jet nozzle and the floor; fabric flap seals were then used between the floor and side walls of the cage to stop air escape. To give ground simulation the floor projected well outside the front of the cage and clear of the nozzle. The rig is illustrated in Fig.1(a) with a test skirt in position.

The apparatus was instrumented so that readings of static and total head could be obtained within the box hull and in the cushion area. Total head readings could also be taken within the skirt itself at several stations by perforating the fabric to accept small probes made up of hypodermic tubing for the purpose; by orienting the probes to give a maximum reading on the manometer it was possible to obtain fairly accurate measurements. The static pressure at any point in the skirt was impossible to measure accurately as very small pitot-static tubes were not readily available; a rough measurement could be obtained by holding a pitot-tube normal to the flow direction but this was very unreliable.

From initial flow surveys it was apparent that a very high proportion of the total head in the box hull was due to dynamic pressure. The ratios of cushion pressure to total head at input, with any skirt fitted, were always much lower than suggested by exponential theory for a given height to thickness ratio of the flexible jet nozzle; a figure of the order of 30% of the theoretical value

was not uncommon. It was decided to modify the input system to increase the proportion of static head and this was achieved by feeding the output from the blower directly into a large settling chamber and connecting the rear of the box hull directly to this chamber. The settling chamber had a volume of about 200 cu ft and contained screens of a fine fabric mesh to reduce the turbulence; the entry to the box hull was rectangular instead of circular as before and surveys of the flow within this area showed that the proportion of velocity head was negligible and the air was substantially static until the discharge slot into the skirt was reached and velocity was acquired. The discharge from the jet was found to be uniform along its length to within an inch or so of the side walls.

No initial provision was made for the measurement of mass flow into the system but it soon became apparent that, with many of the types of skirt employed, it was difficult to determine a true height to thickness ratio for the nozzle and comparison between theory and experiment could not be made by plotting cushion pressure to total head ratio against the height to thickness ratio with any accuracy. An orifice plate meter was thus incorporated in the outlet from the blower to determine the mass flow into the settling chamber and, since the air was virtually stationary in this chamber and the static pressure there was known, it was possible to determine the power input to the skirt as a product of pressure times volume flow per second. As a basis for comparison the cushion pressure achieved could be plotted against the power input for any daylight clearance or per unit exit area to give a measure of the efficiency of different skirts. A sketch of the final test rig used is shown in Fig.1(b).

3 PRELIMINARY TESTS

The first types of skirt design on which experiments were conducted are shown in Fig.2. These skirts are characterised by the fact that they have a definite nozzle bounded by the outer and inner walls of the skirts and the shape is controlled by means of diaphragms. Skirts of this type were made up from a thin two-ply proofed cotton dinghy material and in some cases of a heavier neoprene-proofed nylon material. To provide a standard for what might be termed the optimum performance of a given flexible fabric skirt configuration similar skirts were made up from cardboard possessing natural rigidity as opposed to the rigidity of the flexible skirt achieved through pressurisation.

The initial method used for comparing theory with experiment was the plotting of cushion pressure to total head ratio, p_c/H , against the nozzle

height above the floor to the nozzle thickness ratio, h/t , for a given nozzle angle, θ , measured from the horizontal. Exponential theory gives the relation between these quantities as:-

$$\frac{p_c}{H} = 1 - \exp \left\{ \frac{-2(1 + \cos \theta)t}{h} \right\} \quad (1)$$

After some initial difficulties in completely sealing the skirt area on the rig, the results of the first tests with cardboard skirts with 1.33 in wide nozzles showed that the values of p_c/H obtained for a given h/t were of the order of 90% of those predicted by the theory. This was regarded as a satisfactory demonstration of the efficiency of the skirt and nozzle shape, which had been designed rather arbitrarily in the absence of any aerodynamic data on this type of nozzle flow. On replacing the cardboard skirts by similar fabric skirts the results were disappointing and frequently the measured values of p_c/H were around 50% of the predicted values for a given h/t . The results were not affected by altering the width of the peripheral jet orifice feeding the skirt from 2 in to 10 in or by shortening the skirts and retaining the same nozzle configuration. The skirts of neoprene/nylon fabric were better than those of proofed cotton and it was believed that the improvement was due to the additional thickness and rigidity of this fabric. Attempts were made to stiffen the cotton fabric skirts locally by adding stiff inserts to the diaphragms in the nozzle, and card strips to the outer face of the inner wall of the nozzle; this effectively rigidised the area but left the majority of the skirt flexible and the result was an appreciable increase in efficiency.

The main reason for the discrepancy between the efficiencies of the fabric and cardboard skirts was traced as a result of making flow surveys within the cardboard skirts. It was deduced from the total head readings and the mass flow continuity within the tapering cardboard skirt that the static pressure on the inside of the inner wall of the nozzle was less than the cushion pressure over a region extending upwards from the end of the nozzle for a distance approximately equal to the height of the nozzle above the floor. The effect of this with the fabric skirt was that the excess cushion pressure could partially close the nozzle and thus reduce the jet thickness; the momentum discharge coefficient of the nozzle was effectively being reduced. Marked closure or constriction of the fabric nozzle was not evident but it was apparent that there was no tension in the lower part of the diaphragms inside the nozzle. Attempts to measure the static pressure inside the nozzle and near to the inner wall indicated a tendency for this to be reduced so that a suction effect was produced. The flow surveys

also showed that the jet stream closely followed the vertical outer wall of the skirt whatever the width of the discharge slot and the triangular region behind this stream was filled with air apparently at rest. In an attempt to visualise the flow pattern arising a model was made of the hull and skirt and floor in the form of a trough with walls representing these outlines; this was filled with water which could be released to flow through the skirt, and dye was injected to show the flow pattern. It was evident that the jet clung to the outer wall of the skirt and there was a standing vortex formation between the jet and inner wall of the skirt; the velocities in this vortex region were much too low to be detected on the proper test rig with the instrumentation available.

The design angle of the original skirts' nozzles was either 30° , 45° or 60° but a tendency was always noted for this angle to increase with a skirt fitted on the rig. The exit jet was widely splayed and the jet reaction combined with the cushion pressure tended to make the outer wall of the nozzle kink and change the nozzle angle, particularly when the nozzle was close to the floor and the cushion pressure was relatively high. Whilst this effect might be expected its onset is difficult to predict without a prior knowledge of the pressure forces acting on the skirt and their distribution. It is practically important that nozzle distortion should not occur and that the pressurisation of the skirt should be such that it too is not distorted from the design shape by cushion pressure, jet reaction or dynamic pressure due to forward motion of the craft. The stiffness attainable with a skirt is a function of the internal pressure and its stability in buckling depends on the ratio of its length to base width: the practical limit for this ratio appears to be about 1.5. With 16 in long skirts on a 10 in base the outer wall of the skirts nearest the hull attachment points tended to rise up over the hull, effectively shortening the skirt and causing a change in nozzle angle independent of any kinking at the nozzle due to local buckling. In all the experiments carried out the wide splay of the nozzle exit jet made it impossible to determine a true nozzle angle and mean values had to be taken.

Many variants of the skirts shown in Fig.2 have been tried: nozzle angles have been changed and the width varied; diaphragms have been completely or partially replaced by string ties; partial diaphragms and porous diaphragms instead of full diaphragms have been used; skirts have been shortened in length retaining the same nozzle geometry, and the width and entry angle of the feed slot have been changed. The results obtained from these modifications to the basic type of skirt with definite nozzle were not encouraging: marginal

improvements were sometimes obtained but in many cases the results were considerably poorer. Cylindrical skirts with and without tapered nozzles and horizontal diaphragms as shown in Fig.2 were also tested and some typical results of tests with these skirts and the long-nozzled skirts are shown in Fig.3.

4 THE DEVELOPMENT OF AN EFFICIENT SKIRT

It was evident from the preliminary tests that there were serious discrepancies between the performances of rigid skirts and flexible skirts of the same configuration and that the flexible skirts would reduce the daylight clearance of a craft appreciably. Since the object of the tests was to produce a skirt approaching maximum efficiency, and not just a skirt giving marginal improvement in obstacle clearing capability, effort was concentrated on finding how a flexible nozzle could be designed so that it did not distort or how the problem could be avoided. Although improvement was obtained by locally stiffening the nozzle area this was not felt to be practicable as it was detrimental to the essential feature of flexibility and could be expected to accelerate the wear rate of the skirt.

It was decided to cut back the inner wall of the nozzle in stages to find where nozzle closure ceased to occur and the stages of cutting-back on a long-nozzled skirt are shown in Fig.4. The cutting back process no longer allowed the clear definition of nozzle width and the plotting of p_c/H against h/t did not represent a useful means of comparison. A new basis for comparison was sought and the most practical was found to be the plotting of cushion pressure against power for a given clearance height or per unit exit area.

The effect of cutting back the inner wall of the skirt of Fig.4 is shown in Fig.5. There was a gradual increase in the cushion pressure achieved for a given power input as the skirt was cut back; this was less marked at the 2 in height but was clearly defined at the 4 in and 6 in daylight clearances. The improvement levelled off when the curved inner face of the nozzle was completely removed and no improvement was gained in cutting back further, as is shown in the upper curve of Fig.5 relating to three successive stages. In the final stages of cutting back it was apparent that the skirt with a single outer wall at its extremity was not practically useful as this formed a scoop and was easily damaged by the exit of an obstacle. However, since the cut-back nozzle gave such an improved performance the skirt was redesigned so that the inner wall of the skirt was without curvature and the outer wall did not extend to form a scoop. This re-designed skirt and nozzle is shown in Fig.6 where the nozzle

is effectively only a slot. Further experiments were carried out with this skirt by cutting back the straight inner wall; it was found that once the exit hole size exceeded 1.5 in there was no improvement in the cushion pressure achieved for a given power and it was immaterial whether or not there was an inner wall. The results of these tests are shown in Fig.7 where the experimental points follow the full lines with negligible scatter.

The implication of these tests is that the simplest type of skirt is one consisting of a single outer wall with its shape retained by diaphragms attached to the craft hull inboard of the feed jet. However it has already been remarked that this type of skirt tends to scoop up water and debris and catch on obstacles, but by making the skirt in small separate individual sections or convolutes which can flex outwards locally, without excessive loss of cushion pressure, much can be done towards eliminating the practical problems. This particular approach has been adopted to some extent by both H.D.L. and Vickers in skirting systems.

5 COMPARISON BETWEEN THEORY AND EXPERIMENT

It is difficult to obtain a satisfactory direct method of comparing the experimental results with theory. It is evident from the results of cutting back the inner wall of the long-nozzled skirt and the re-designed skirt with straight inner wall that the actual jet thickness to be used in any theory is not necessarily the width of the skirt exit nozzle. It can easily be shown (e.g. Ref.1) that for a given configuration the power required is directly proportional to $p_c^{3/2}$, but the factor of proportionality is a function of the jet thickness and other geometric characteristics and its magnitude is different for the two principal peripheral jet theories currently in use. By determining the critical values for the factor of proportionality geometric parameters can be chosen such that the power required for a given cushion pressure can be minimised. It is with this optimum situation that the results obtained in the present tests have been compared.

On the momentum theory, in which it is assumed that the static pressure in the peripheral jet is the mean of the cushion and atmospheric pressures, it can be shown that

$$\frac{P_c}{H} = \frac{2x}{1+x} \quad (2)$$

where

$$x = \frac{t}{h} (1 + \cos \theta) \quad (3)$$

and the power required is

$$P = \frac{\ell h p_c^{3/2}}{2\rho^{1/2} (1 + \cos \theta)} \left[\frac{1+x}{x^2} \right] \quad (4)$$

where ℓ is the jet length and ρ the atmospheric density. For given values of the other variables this power is a minimum for $x = 1$, and setting $\theta = 45^\circ$ it can be shown that in this optimum case

$$p_c^{3/2} = 3.88 \left(\frac{P}{\ell h} \right) \quad (5)$$

where p_c is measured in inches of water gauge, P is in horse-power and ℓ and h are in feet. However, when $x = 1$, p_c/H also is unity and this is a situation which could not be achieved in practice.

On exponential theory it can be shown that

$$\frac{p_c}{H} = 1 - e^{-2x} \quad (6)$$

and the power required is

$$P = \frac{\sqrt{\frac{2}{\rho}} \ell h p_c^{3/2}}{(1 + \cos \theta)} \frac{(1 - e^{-x})}{(1 - e^{-2x})^{3/2}} \quad (7)$$

In this case the minimum for power is obtained when $x = 0.7$, and again setting $\theta = 45^\circ$ the optimum case is given by

$$p_c^{3/2} = 3.55 \left(\frac{P}{\ell h} \right) \quad (8)$$

where p_c is in inches of water gauge, P in horse-power and ℓ and h in feet.

At the values of x around unity the exponential theory is generally regarded as more satisfactory than the momentum theory and, as many experimentalists results support this, equation (8) is used in the present study to give the optimum situation with which all the static test results can be compared.

6 EXPERIMENTAL RESULTS

It was shown both in flow surveys and by flow visualisation that the main jet stream closely followed the vertical outer wall of the skirt and that the majority of the mass flow occurred in a layer close to this outer wall and the

velocity dropped rapidly across the jet as it approached the inner wall. It was found with cardboard skirts having 1.33 in wide nozzles that the velocity profile was reasonably flat across the jet, but on widening the nozzle to 2 inches and to 3 inches there was no great effective increase in jet width because so little flow was occurring towards the inner wall. The card skirts used in these experiments with varying nozzle widths are shown in Fig.8. The plot of p_c/H against h/t for card skirts with 1.33 in wide nozzles showed reasonable agreement with exponential theory and about 90% of the theoretical value of p_c/H was achieved; the results for the 2 inch and 3 inch nozzles gave progressively lower values for p_c/H as is shown in Fig.9. The slopes of the three curves passing through the experimental points might have been expected to be the same but the effective jet width, which one might define as the width over which a fixed percentage of the mass flow takes place, appears also to be a function of the daylight clearance height. On plotting the cushion pressure against the power input to the card skirts with different nozzle widths it was found that for a given daylight clearance the experimental points followed substantially the same lines for all three nozzles; these points are shown plotted in Fig.10 for a range of clearance heights. It was thought that the jet stream width could be a function of the slot entry size to the skirt and readings were taken for feed slot widths of 2, 5 and 10 inches; the results for a 2 inch daylight clearance are shown in Fig.11 and indicate that within the range of experimental error the feed slot width made negligible difference.

Because the fabric skirt of the original design shown in Fig.6 was found to have a tendency to catch on obstacles it was modified by the addition of a small straight nozzle to the exit slot as shown in Fig.12. Tests with this skirt showed that it gave almost identical results to the unmodified version. A further skirt was made up in fabric to a design similar to the type apparently used by Saunders-Roe on their hovercraft; this skirt is shown in Fig.13 and the test results showed that it was slightly inferior in performance to the skirt of Fig.12. A convoluted skirt, similar to the Vickers and H.D.L. types, was also constructed and this is shown in Fig.14; the skirt has no inner wall and is extremely flexible and readily permits the ingress of obstacles, it is also easily deflected outwards by the egress of obstacles. In view of the early experiences with cutting back the inner walls of skirts it was expected that this skirt would give good results; this was confirmed as the results were very similar to those obtained with the Saunders-Roe type of skirt. The results of all these tests are given in Fig.15 where cushion pressure achieved is plotted

against power per unit exit area; Fig.15 also shows the results obtained with cardboard skirts and the optimum theoretical line plotted from equation (8). Mean lines have been drawn through the experimental points. It can be seen from Fig.15 that for a given power input to the skirt there is a drop of the order of 25% in cushion pressure below the optimum value with the fabric skirts tested. A reasonable fit to the best fabric skirt data is given by the expression

$$p_c^{3/2} = 2.1 \left(\frac{P}{\ell h} \right) \quad (9)$$

where p_c is in inches of water gauge, P in horse-power and ℓ and h in feet. The expression appears to be valid up to $p_c = 2.0$ in and it may be reasonable to extrapolate to considerably beyond this pressure; however it is desirable that tests should be carried out at more representative cushion pressures up to 10 inch water gauge using a larger blower.

The agreement with the optimum theory is not good but it should be borne in mind that the theory may be inadequate and it may be impossible to achieve optimum conditions to comply with its requirements. For example, the theory is based on a parallel jet exuding from the nozzle whereas in practice the jet is splayed outwards; part of the jet enters the cushion to provide energy for a vortex motion and the remainder escapes through the exit area clearance: the simple theories do not take account of this behaviour.

7 TESTS WITH A NON-VERTICAL SKIRT FEED SLOT

In the course of these tests to determine a skirt suitable for the Naval Air Department CC-2 hovercraft with a 90° peripheral jet a request was received to explore the possibilities of fitting a similar skirt to the CC-2 belonging to the Fighting Vehicles Research and Development Establishment at Chobham. The F.V.R.D.E. craft has a peripheral jet inclined at 30° to the horizontal and in order to avoid loss of cushion area the configuration shown in Fig.16 had to be adopted for the scale model to fit on the test-rig. In this case the peripheral jet necessarily discharges onto the inner wall of the skirt and it was expected that the flow losses would be considerable: this was confirmed by the tests and the results in comparison with the N.A.D. CC-2 feed slot configuration are shown in Fig.17. The results of these tests served to emphasise the importance of designing the peripheral jet feed system to the skirt in conjunction with the skirt itself.

8 CONCLUSIONS

Several simple but important conclusions can be drawn from the results of this preliminary study:

- (1) A flexible fabric skirt nozzle may close locally due to pressure forces and it is advisable to design the nozzle so that this closure does not occur. The nozzle design will remain a matter of trial and error until the flow through a skirt-nozzle combination is understood and the pressure forces acting are predictable.
- (2) Even if a flexible skirt nozzle does not close locally its effective width is probably less than its actual width. This implies that there is a discharge coefficient to be included in any calculations and this coefficient needs determining experimentally for each hull-skirt-nozzle combination.
- (3) The discharge coefficient for a flexible skirt nozzle may not be a constant but a function of several variables including daylight clearance and cushion pressure.
- (4) Without knowing the discharge coefficient the comparison between experiment and theory is likely to be meaningless. One can, however, directly compare particular configurations on the basis of power input to a skirt to generate a given cushion pressure for a specified daylight clearance. From the practical point of view this is the most useful comparison available and gives a realistic estimate of the power required for a given static hovering performance excluding losses in fans, shafting and ducting to the peripheral jet feed.
- (5) The tests conducted confirm that the power per unit exit area is directly proportional to the cushion pressure to the three halves for the configurations used.

e.g.

$$p_c^{3/2} = \lambda \left(\frac{P}{\ell h} \right)$$

For the hull-skirt-nozzle configuration employed $\lambda \approx 2.1$ where p_c is in inches of water gauge, P in horse-power and ℓ and h in feet.

- (6) It is imperative that the peripheral jet system on a basic hovercraft should be designed in conjunction with the skirt and that the skirt should not be regarded as an ancillary if an optimum performance is desired.

(7) Future work should extend the present test results to higher cushion pressures and effort should be devoted to deriving a theoretical analysis of the flow within a typical skirt to determine the pressure distribution and the forces acting on the skirt resulting from dynamic effects and cross flow and vortex flow within the cushion area.

REFERENCE

<u>No.</u>	<u>Author</u>	<u>Title, etc.</u>
1	W.A. Mair	The physical principles of hovercraft. J. Roy. Aero. Soc. Vcl. 68 No. 646 October 1964 pp.683-691

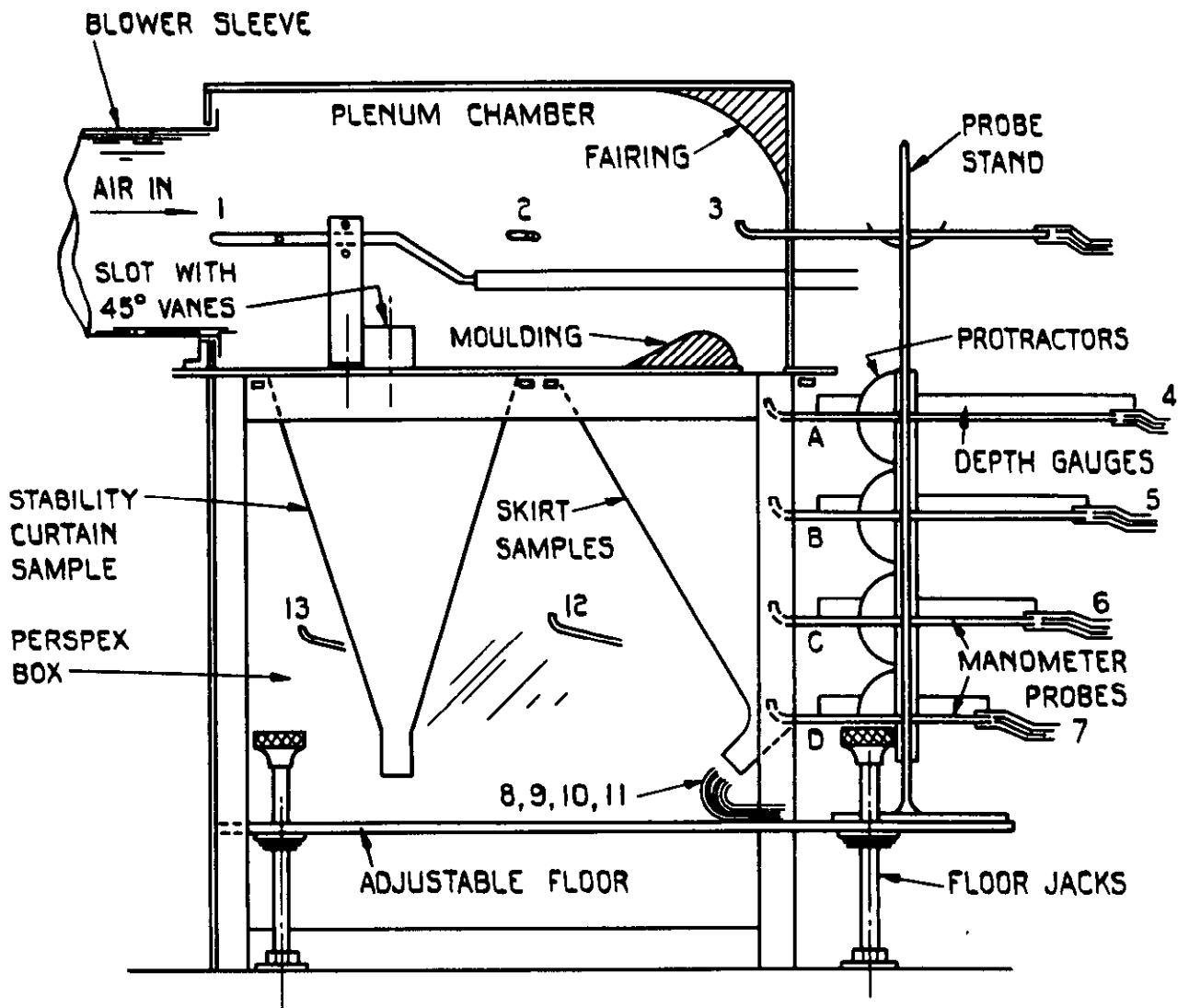

PROBES

- 1 STATIC PROBE
- 2 SIDE PROBE - PLENUM CHAMBER BOX
- 3 FRONT PROBE - PLENUM CHAMBER BOX
- 4,5,6,7 SKIRT PROBES
- 8,9,10,11 COMB PROBE - JET
- 12 PROBE - OUTER CUSHION
- 13 PROBE - INNER CUSHION
- 14,15,16,17 PROBES - STABILITY CURTAINS
- 18 WANDERING PROBE - STATIC
- 19 WANDERING PROBE - DYNAMIC
- 20 SPARE

FIG.1(a) TEST RIG-FLEXIBLE SKIRTS

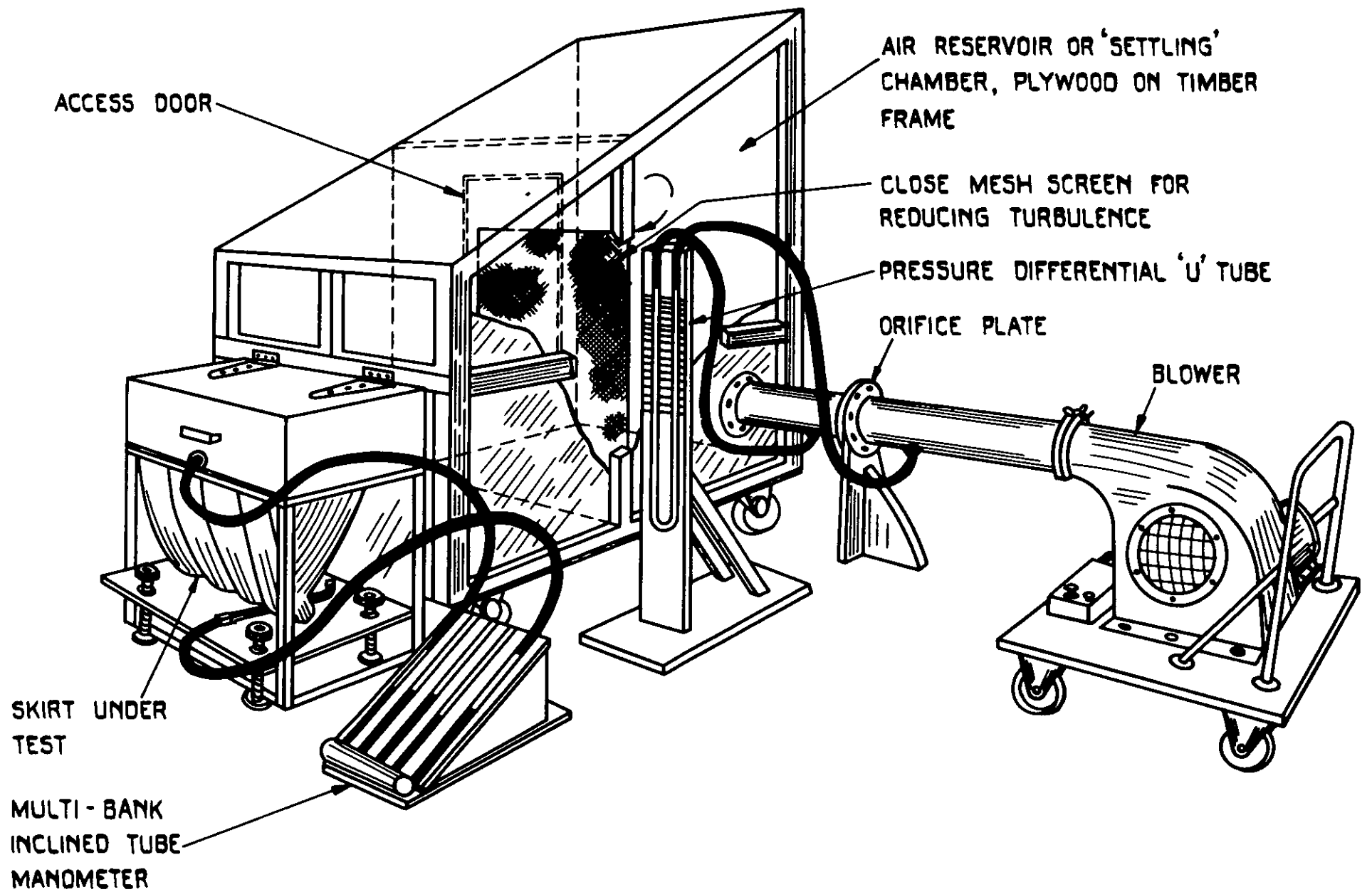

FIG.1 (b) TEST RIG FOR FLEXIBLE SKIRTS

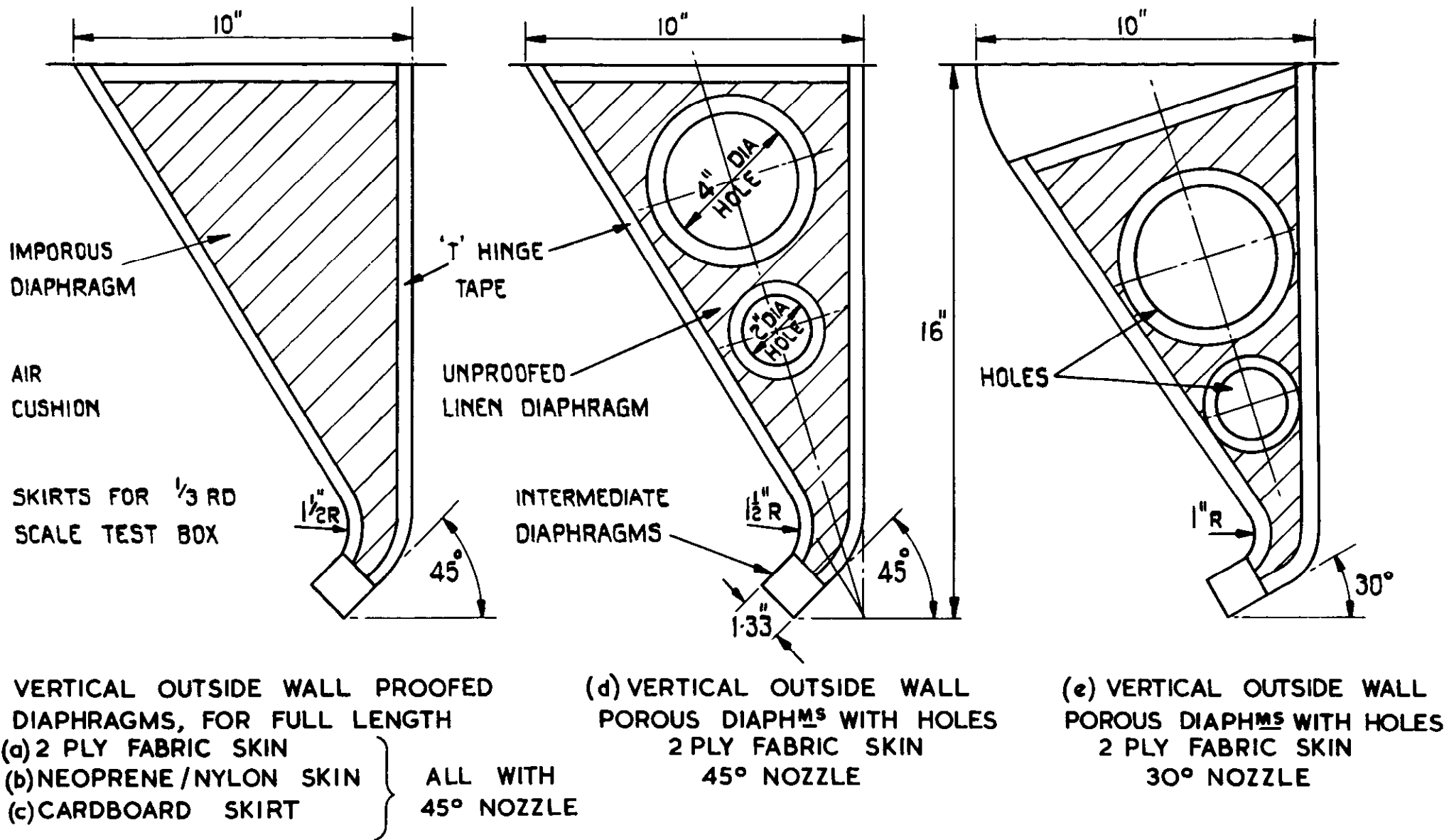

FIG.2 (a,b,c,d,e) TYPICAL TYPES OF SKIRT TESTED

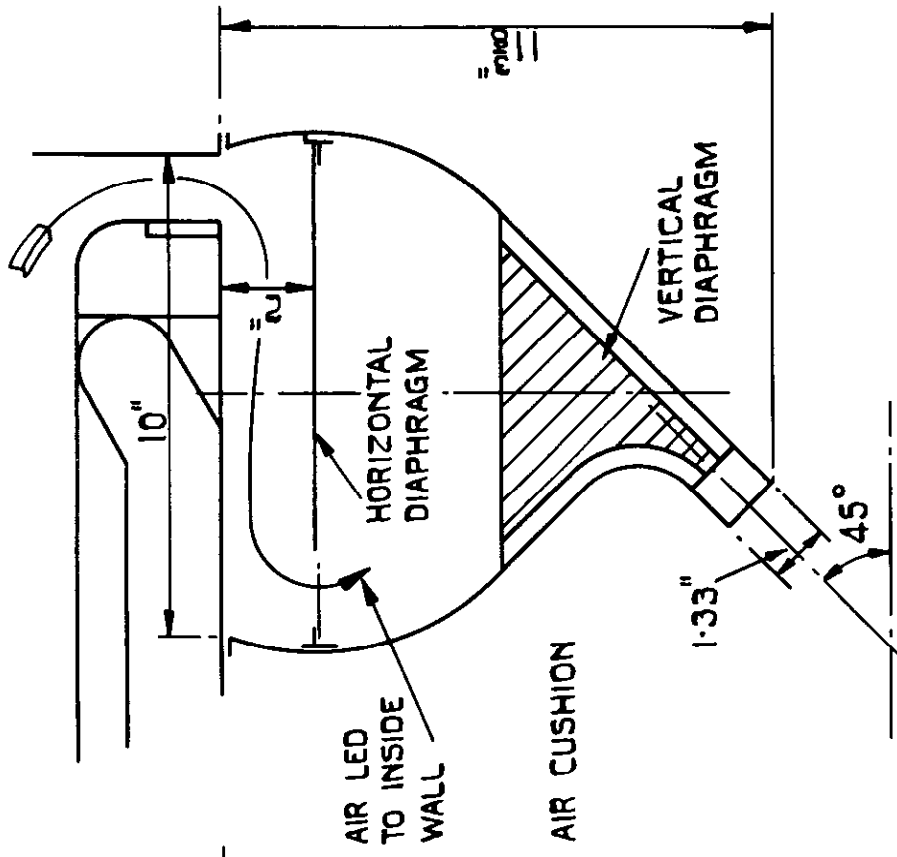

FIG. 2 (g) LONG SKIRT

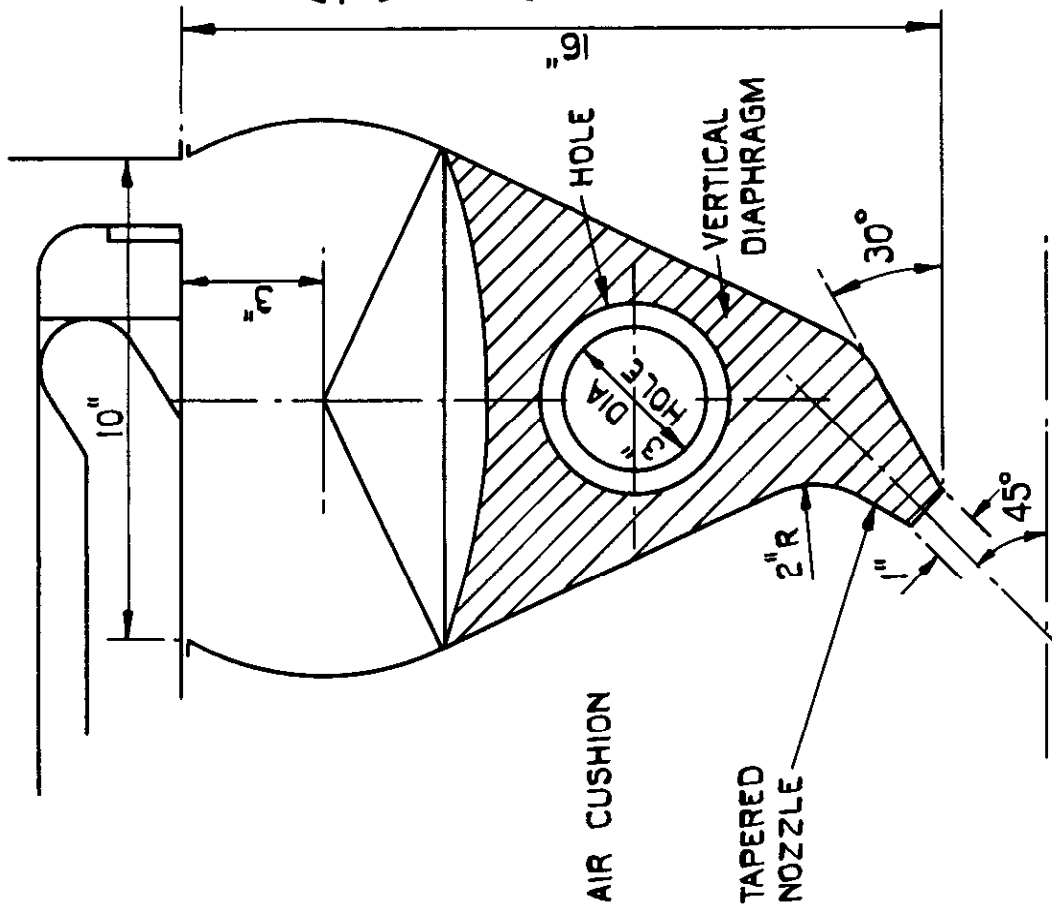

FIG 2 (f) LONG SKIRT

FIG 2 (f & g) TYPICAL CYLINDRICAL SKIRTS FIG. 2 (f & g)

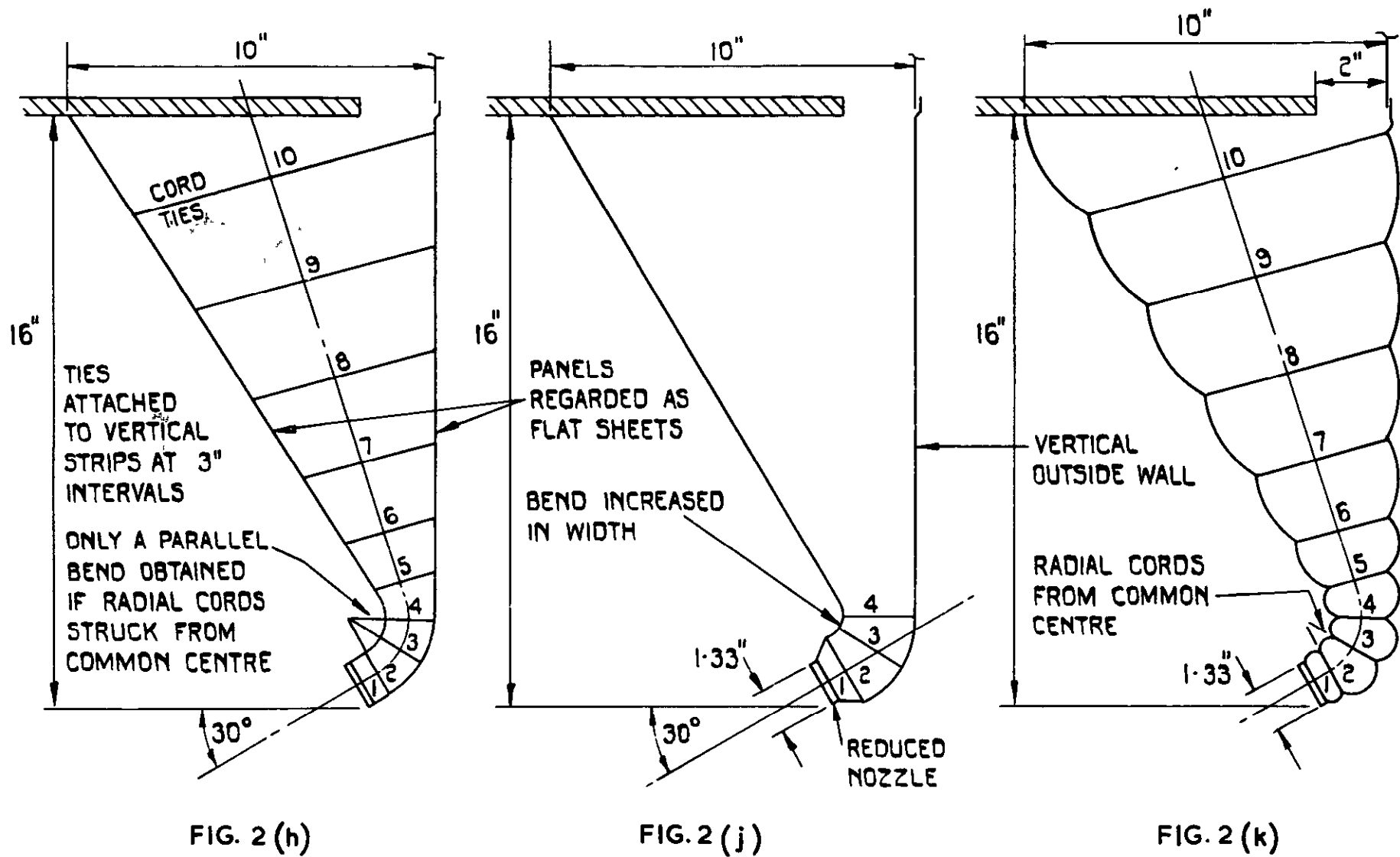

FIG. 2 (h,j&k) SKIRTS WITH CORD TIES $\frac{1}{3}$ RD SCALE MODEL

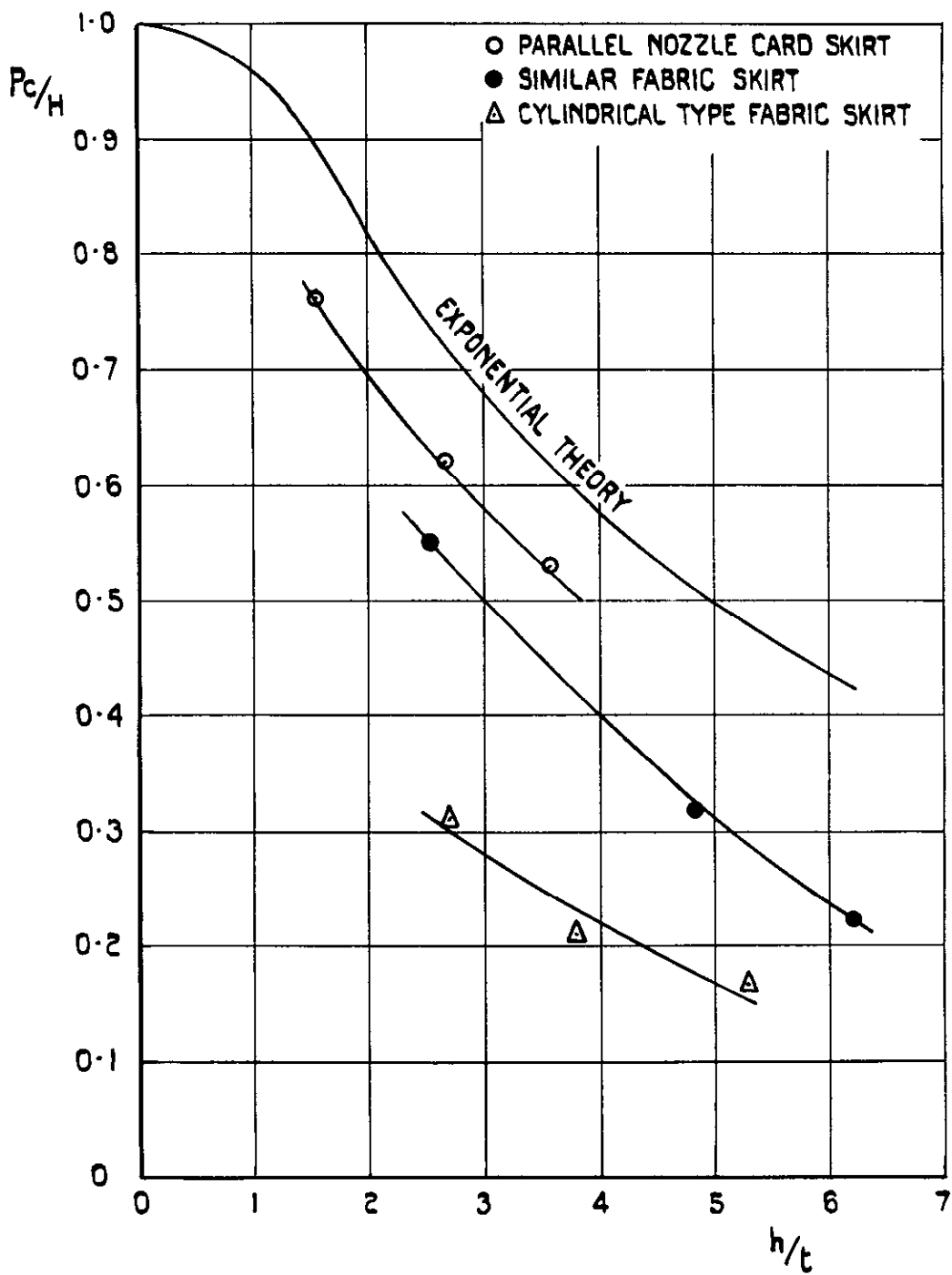

FIG.3 TYPICAL PERFORMANCE OF EARLY SHAPED NOZZLE SKIRTS NOZZLE ANGLE 45° WIDTH 1.33 INCHES

MEDIUM LENGTH SKIRT WITH NOZZLE - 12" LONG

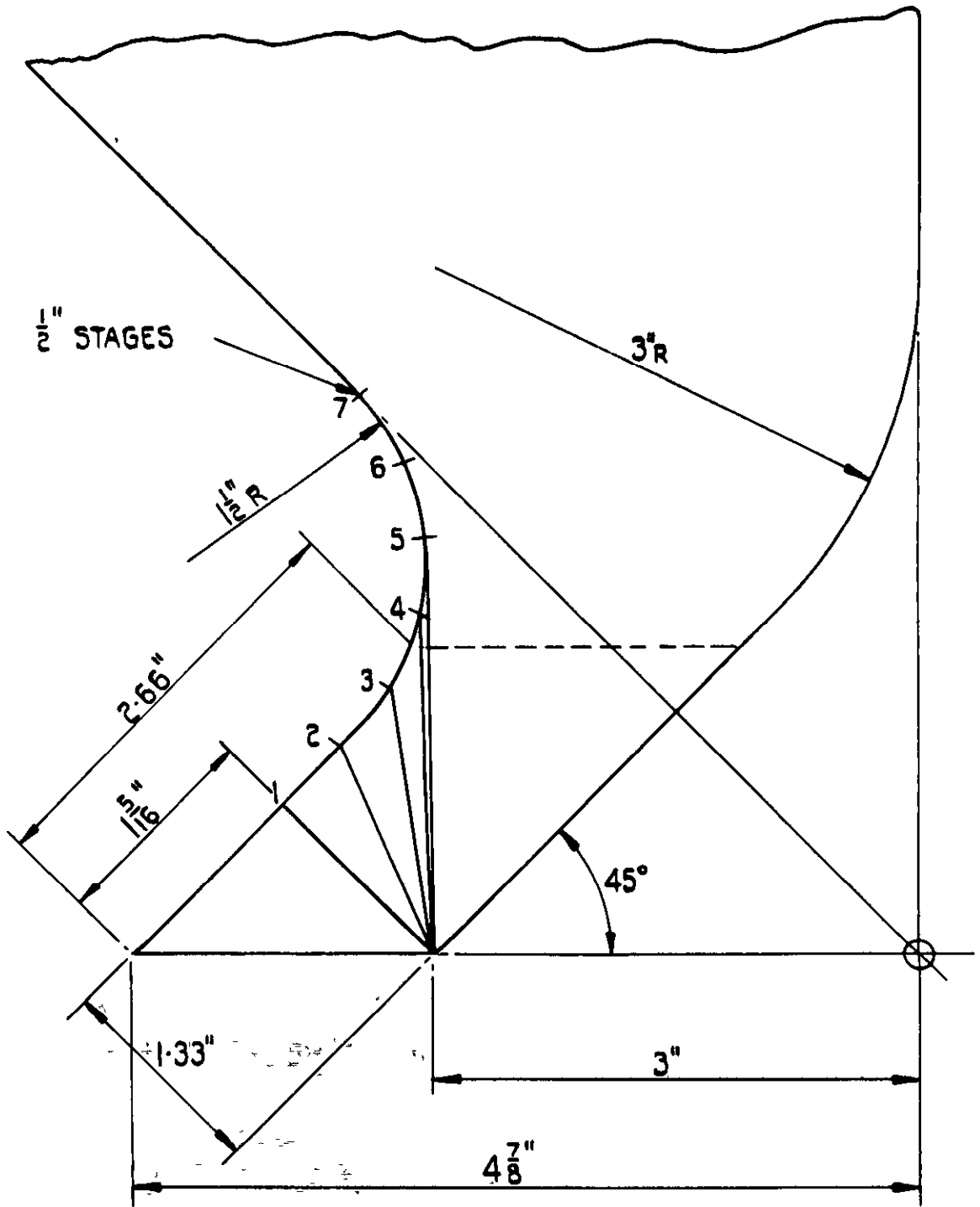
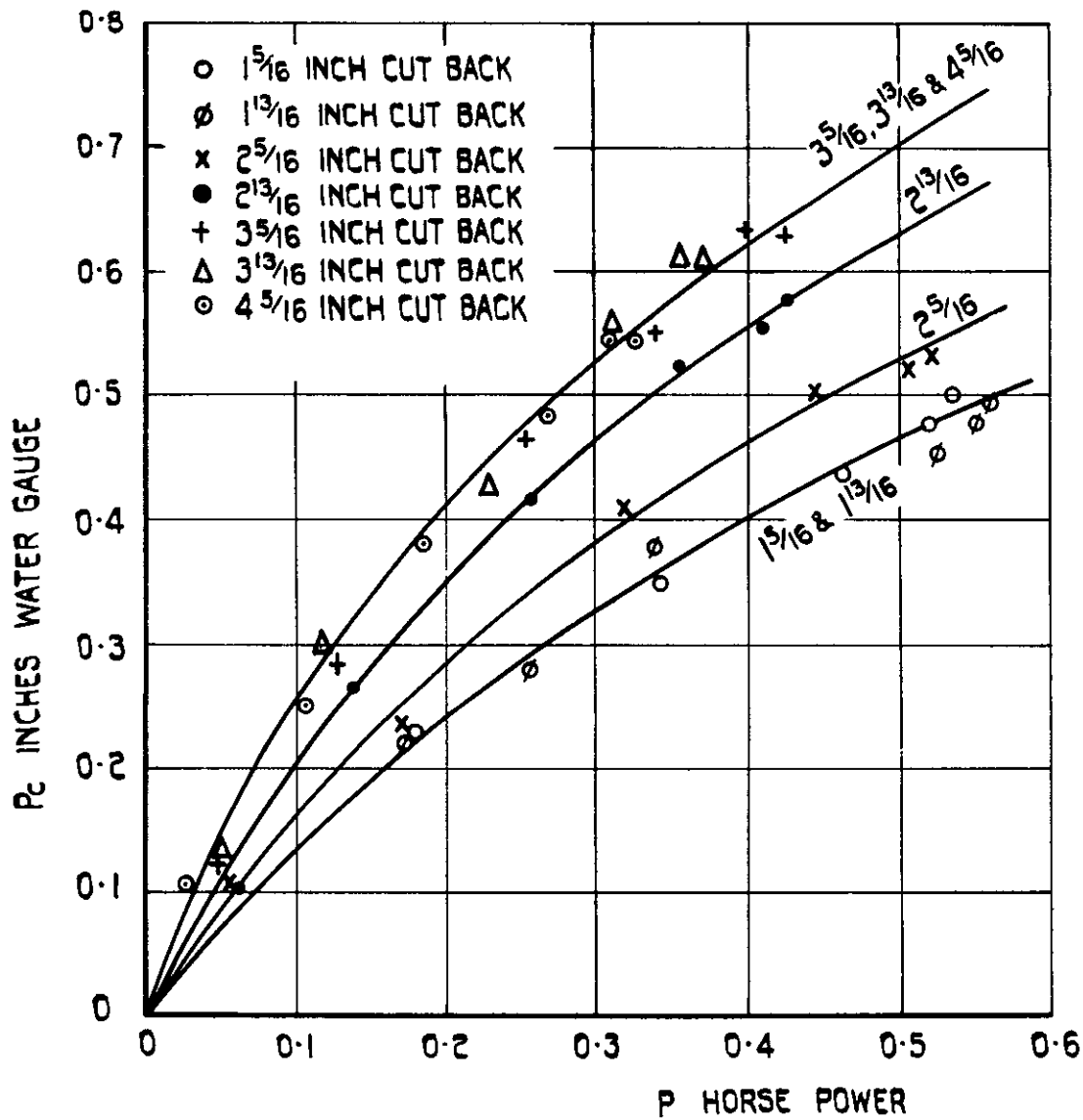

FIG.4 STAGES IN CUT BACK OF INNER WALL



ALL READINGS TAKEN AT A CLEARANCE HEIGHT OF 6 INCHES

FIG.5 THE EFFECT OF CUTTING BACK THE INNER FACE OF THE NOZZLE OF A PARALLEL NOZZLED FABRIC SKIRT

10" LONG RADIUS OUTER WALL SKIRT

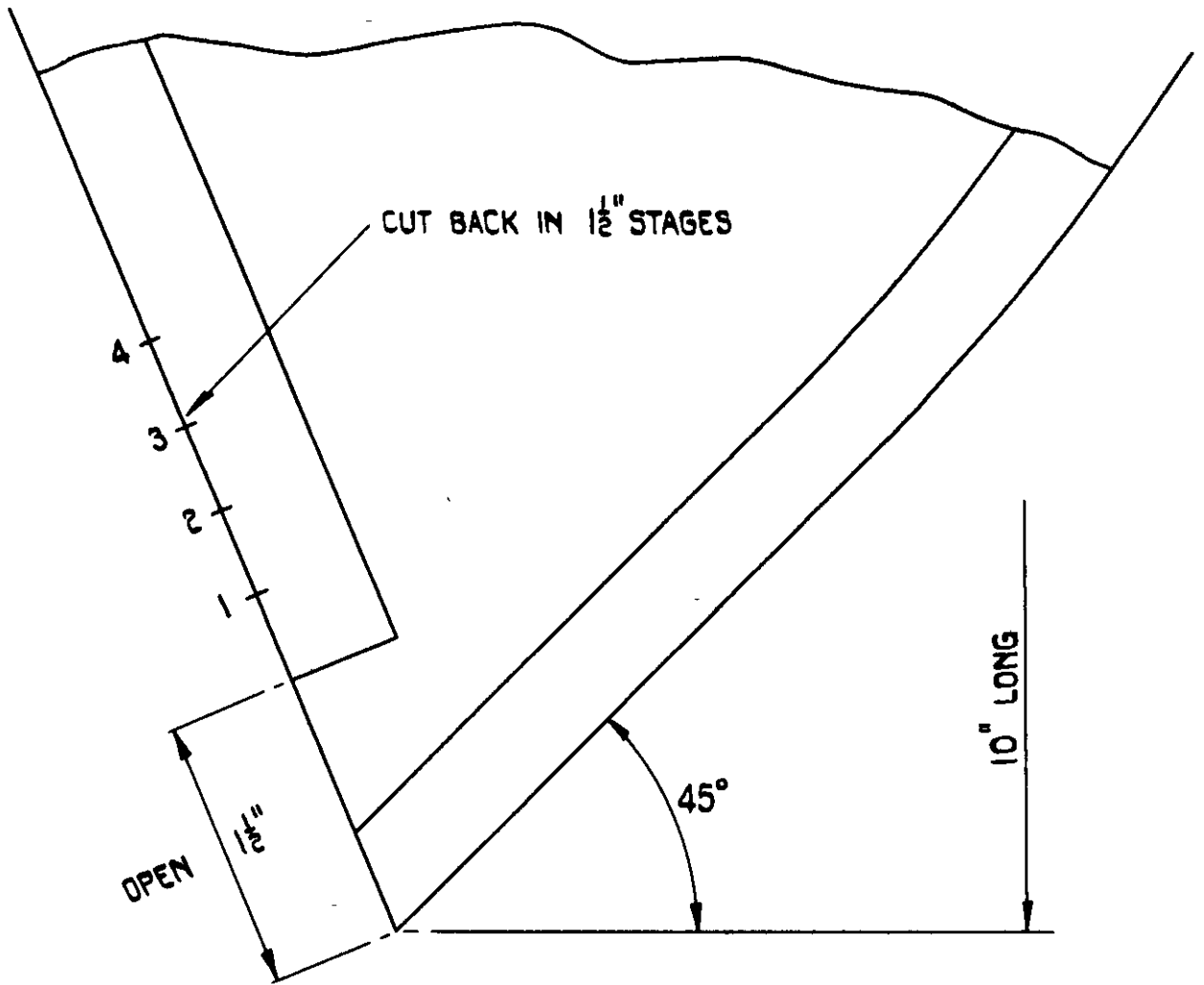

FIG. 6 STAGES IN CUT BACK OF INNER WALL

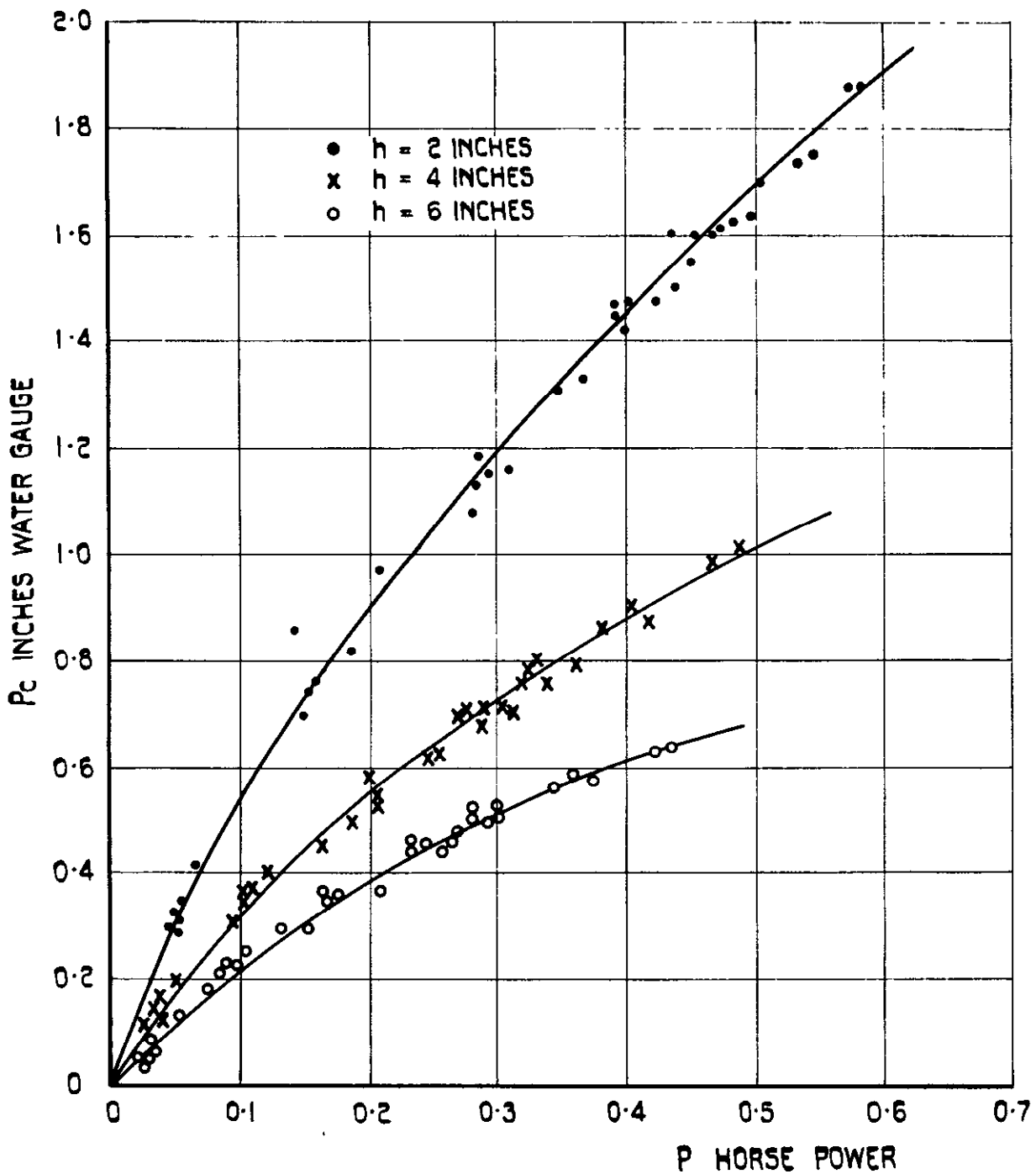

FIG.7 CUTTING BACK THE INNER FACE
 OF THE RE-DESIGNED FABRIC SKIRT IN
 $\frac{1}{2}$ INCH STAGES FROM $1\frac{1}{2}$ TO 4 INCHES

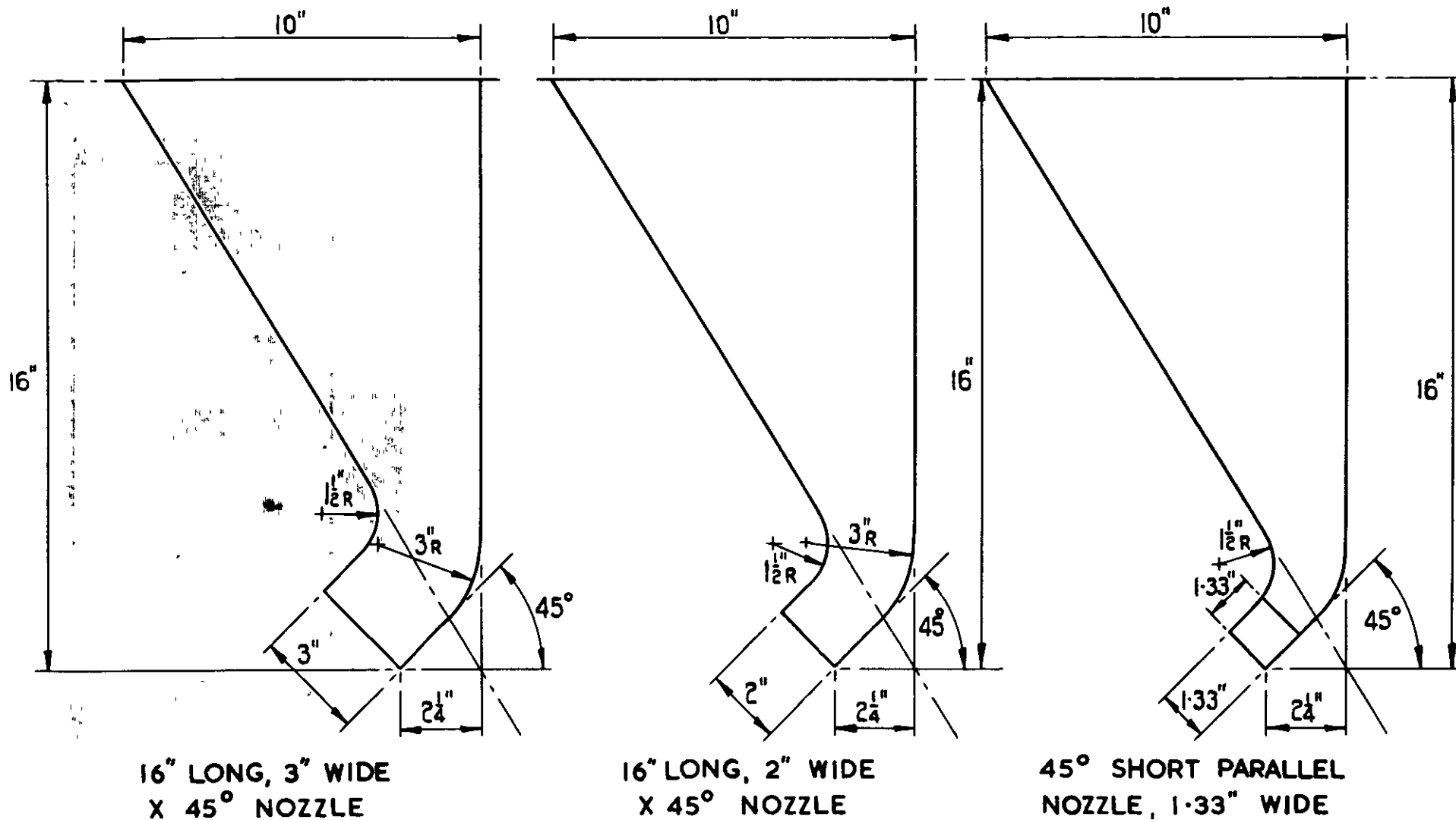

FIG. 8 CARDBOARD SKIRTS, 16" LONG X 45° NOZZLES, 3", 2" & 1.33" WIDE

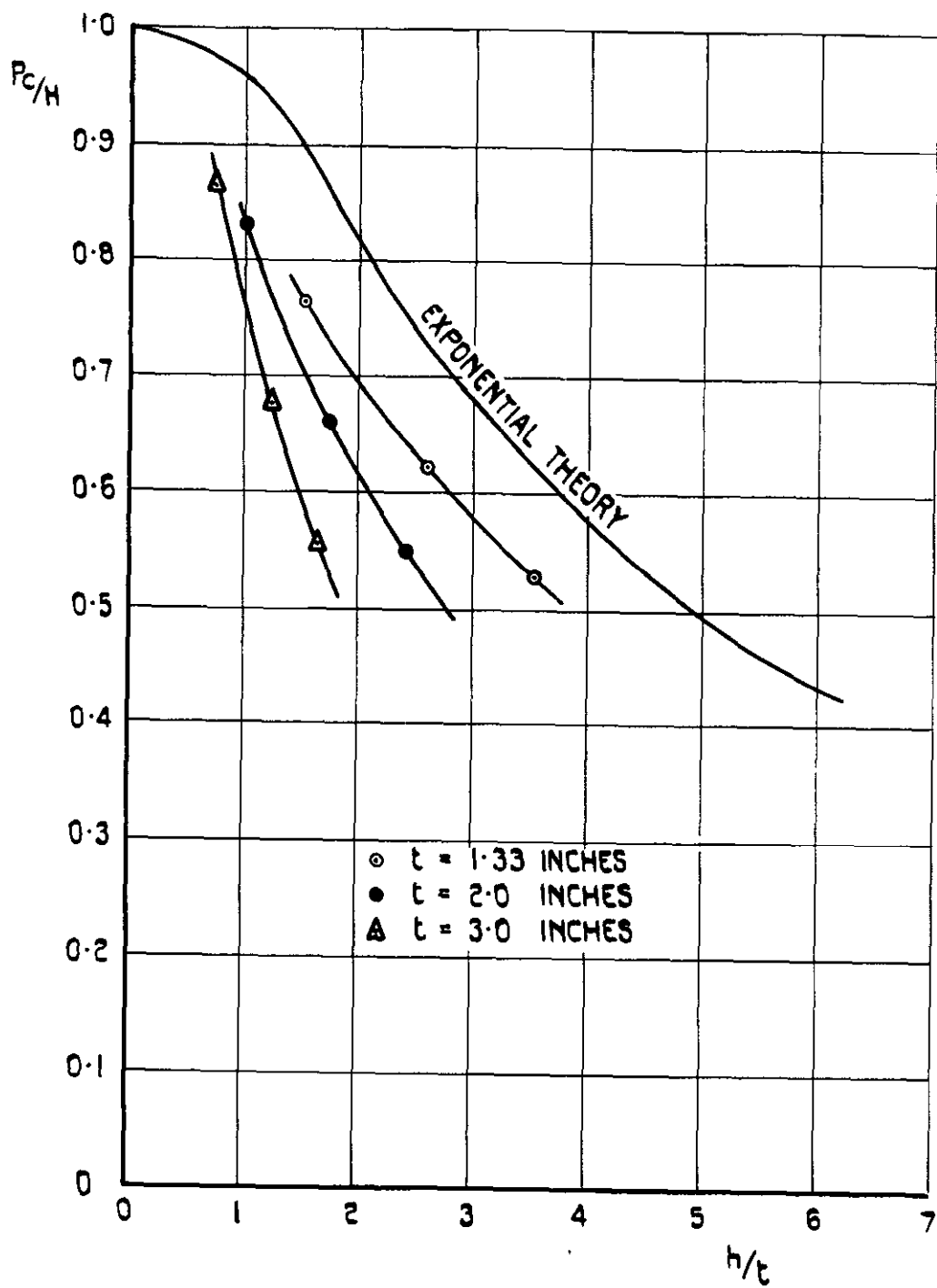

FIG.9 GRAPH OF P_c/H AGAINST h/t FOR CARD SKIRTS WITH NOZZLE ANGLE OF 45° AND VARYING NOZZLE WIDTHS

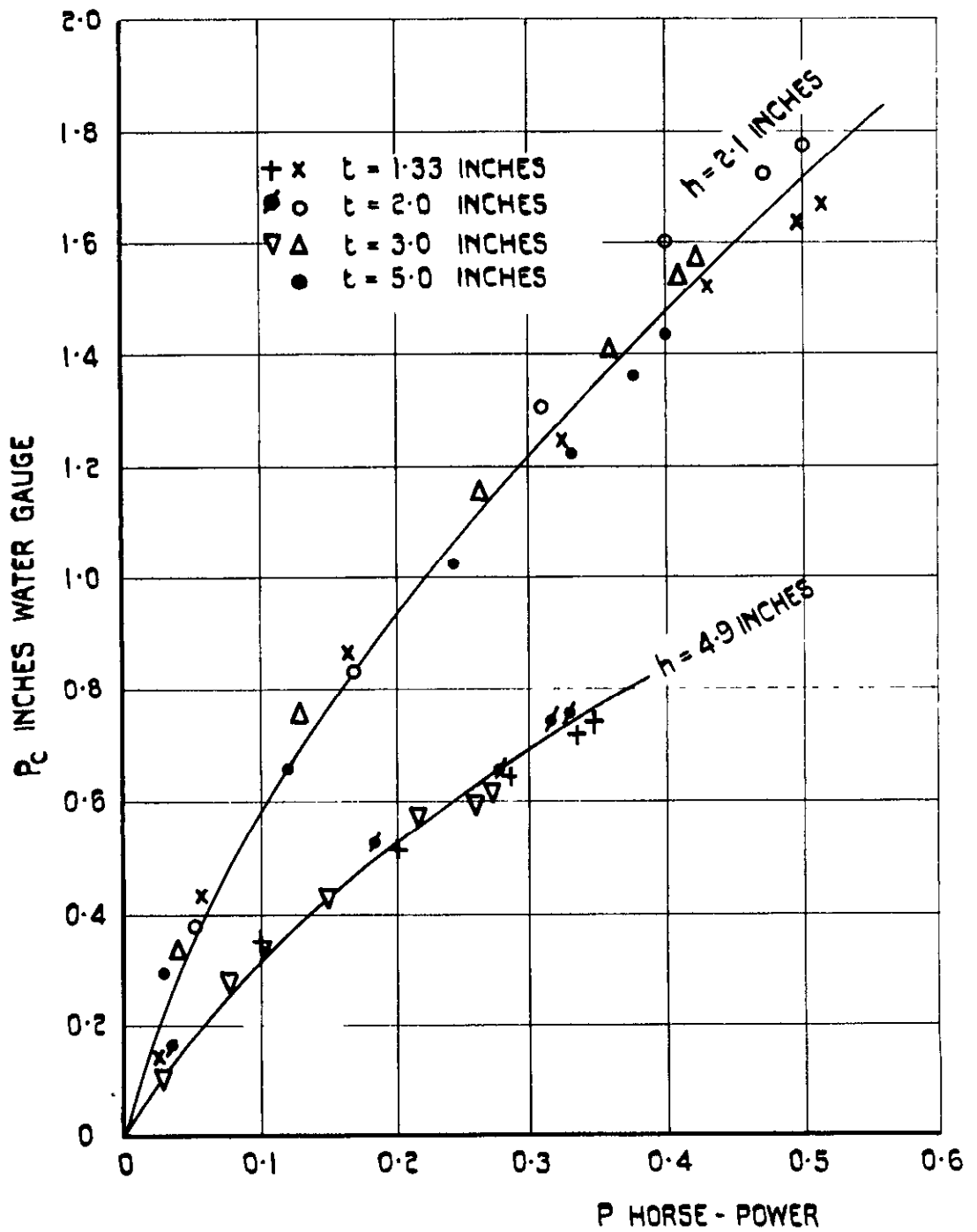

FIG.10 GRAPH OF CUSHION PRESSURE AGAINST POWER FOR CARD SKIRTS WITH VARYING NOZZLE WIDTHS

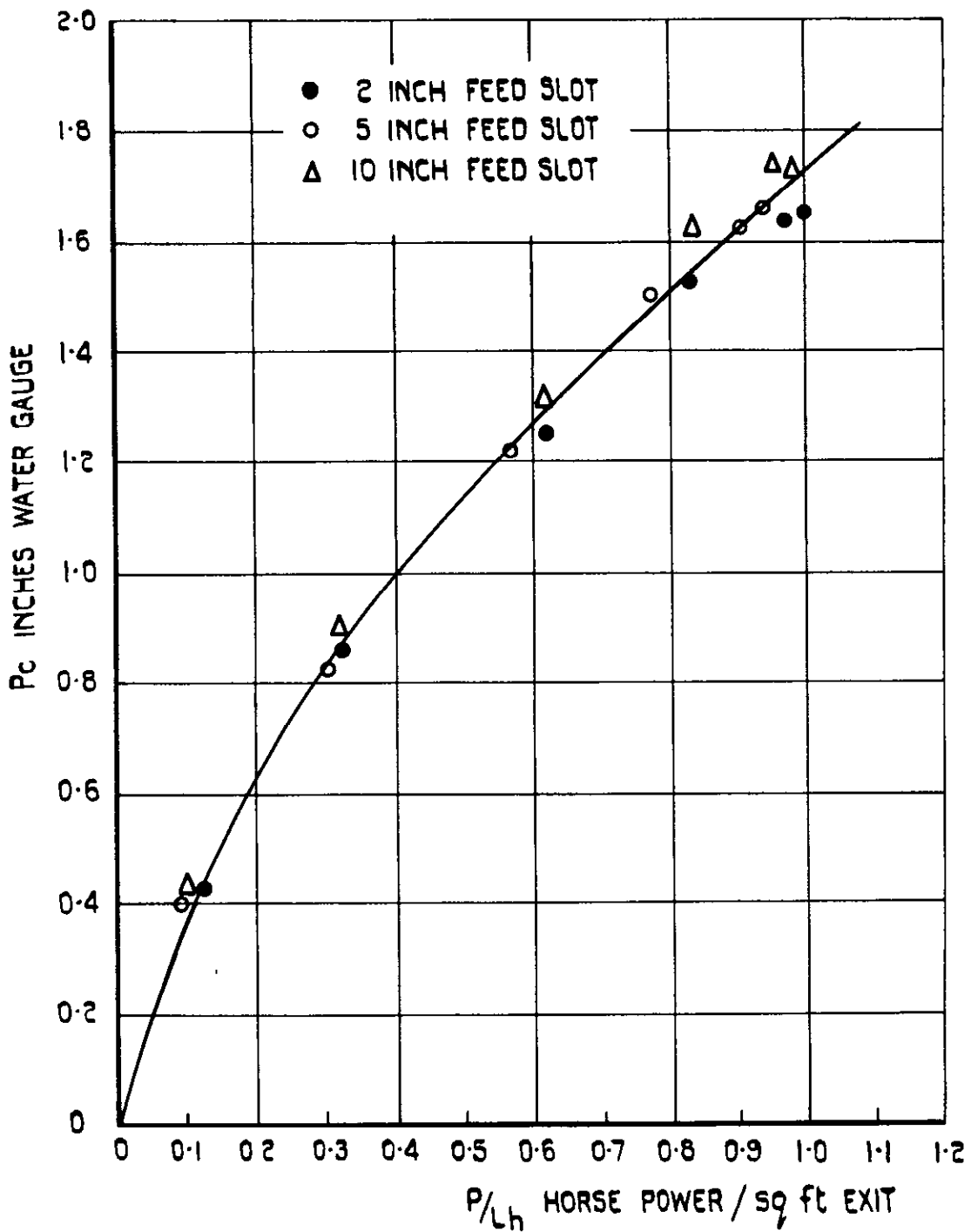
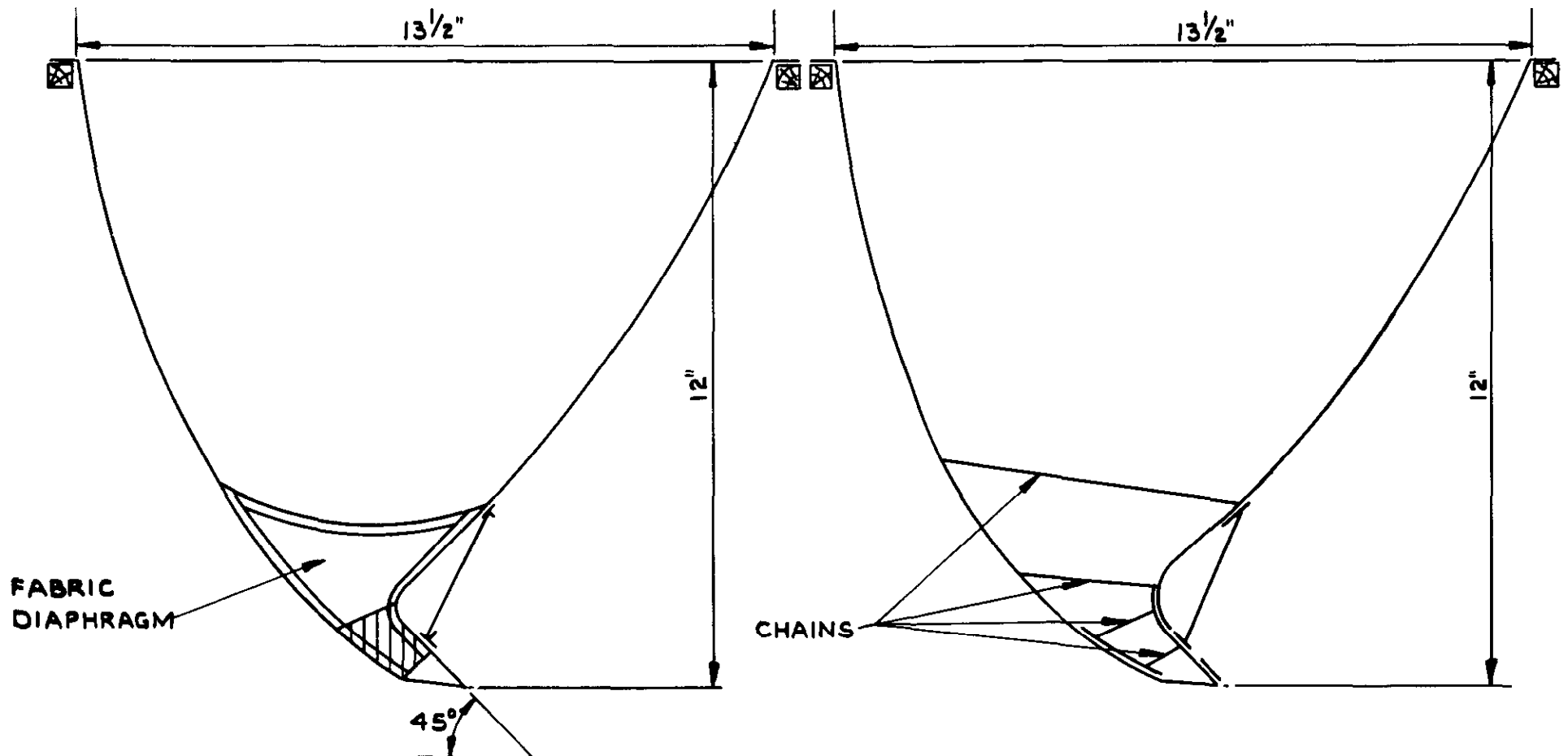

FIG. II THE EFFECT OF VARYING FEED SLOT WIDTH
CARD SKIRT WITH $t = 1.33$ INCHES $\theta = 45^\circ$
PARALLEL NOZZLE CLEARANCE HEIGHT = 2.06 INCHES



SR DIAPHRAGMED SKIRTS
 ONE IN THIN FABRIC
 ONE IN THICK FABRIC

SR CHAIN TYPE SKIRTS
 ONE IN THIN FABRIC WITH CORD TIES
 ONE IN THICK FABRIC WITH CHAINS

FIG.13 SAUNDERS-ROE TYPE SKIRTS

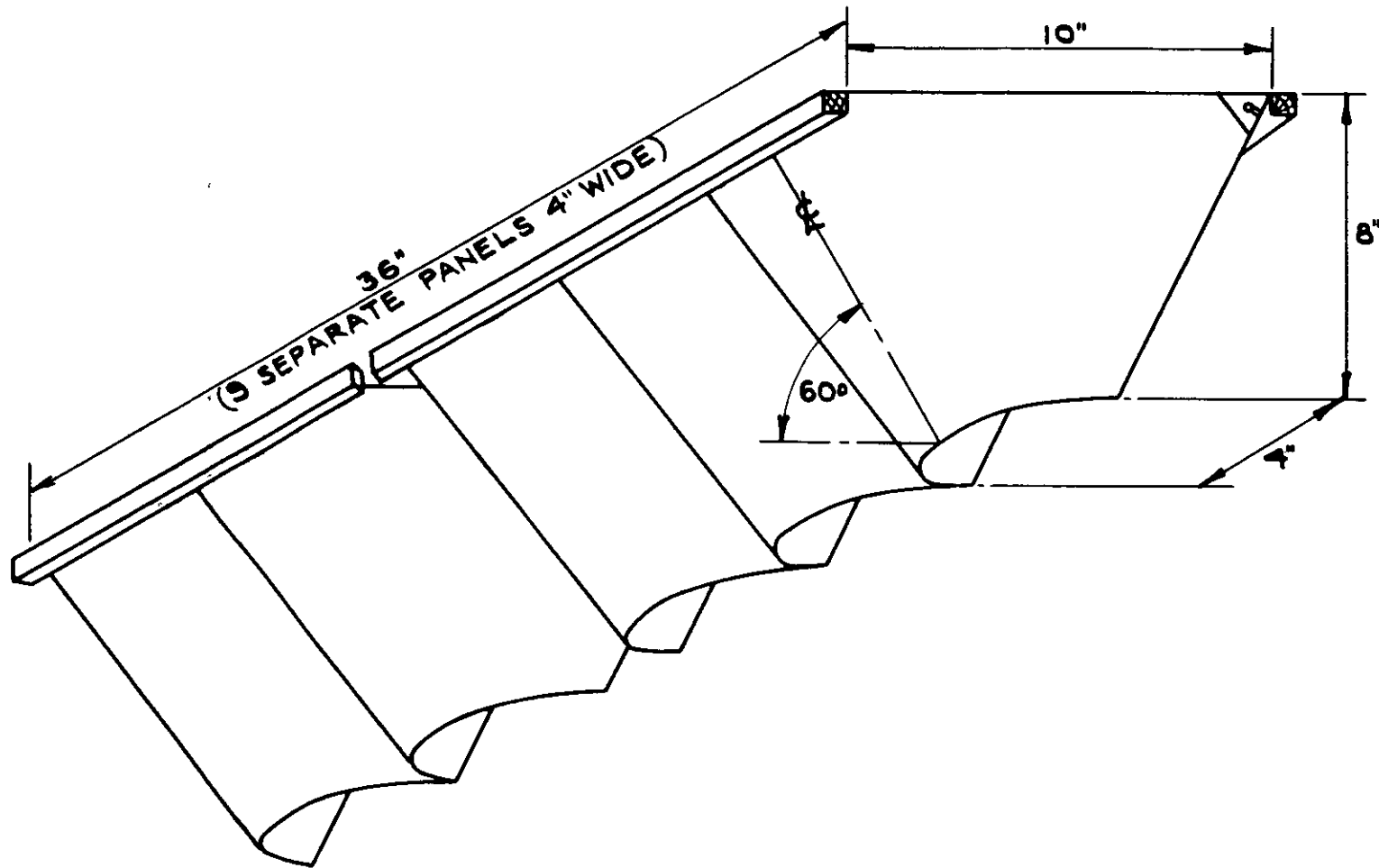

FIG. 14 CONVOLUTED SKIRT-HDL TYPE-60° INCIDENCE

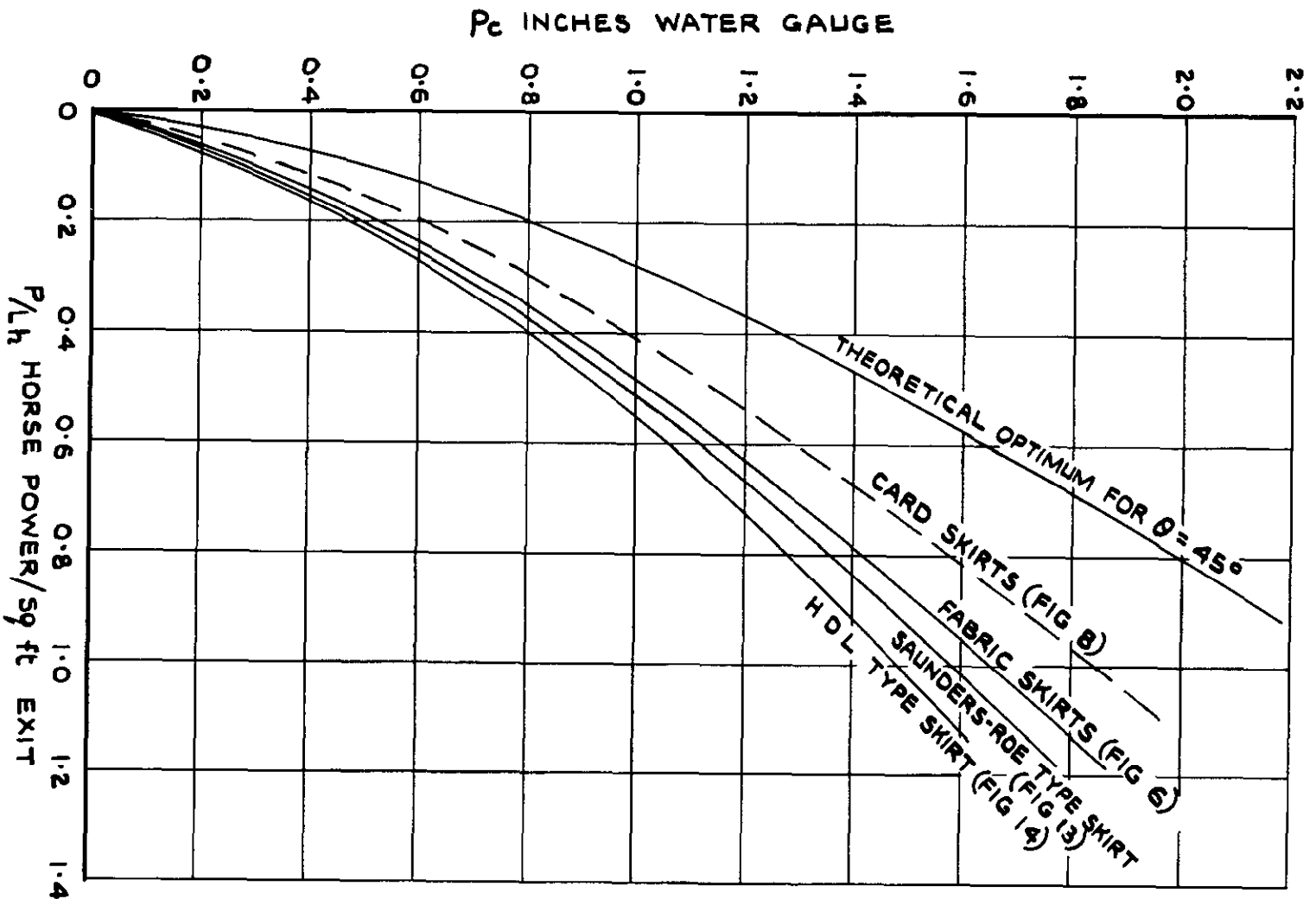

FIG.15 COMPARISON OF MAIN TYPES OF SKIRT TESTED

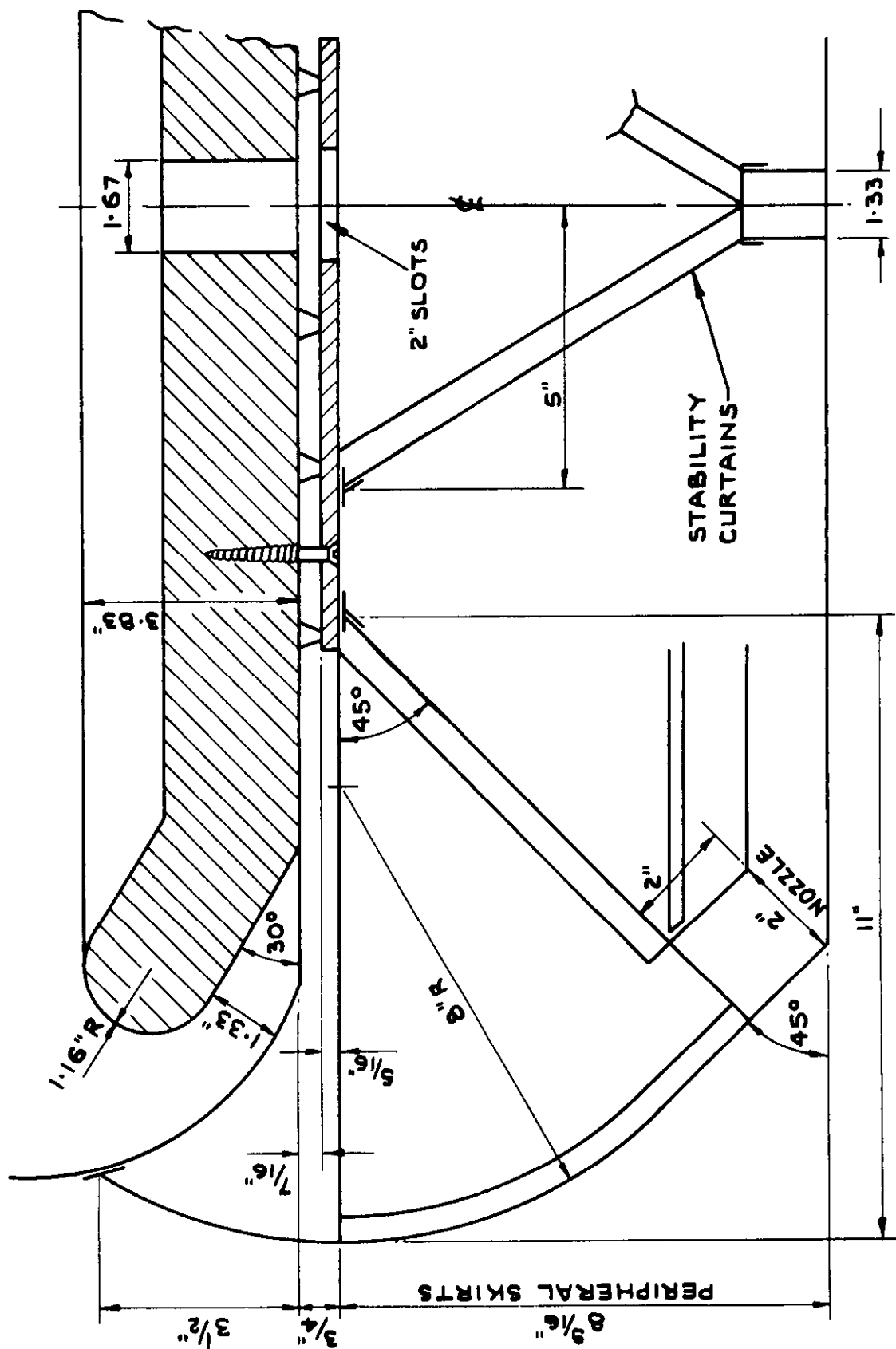

FIG.16 F.V.R.D.E. TYPE SKIRTS

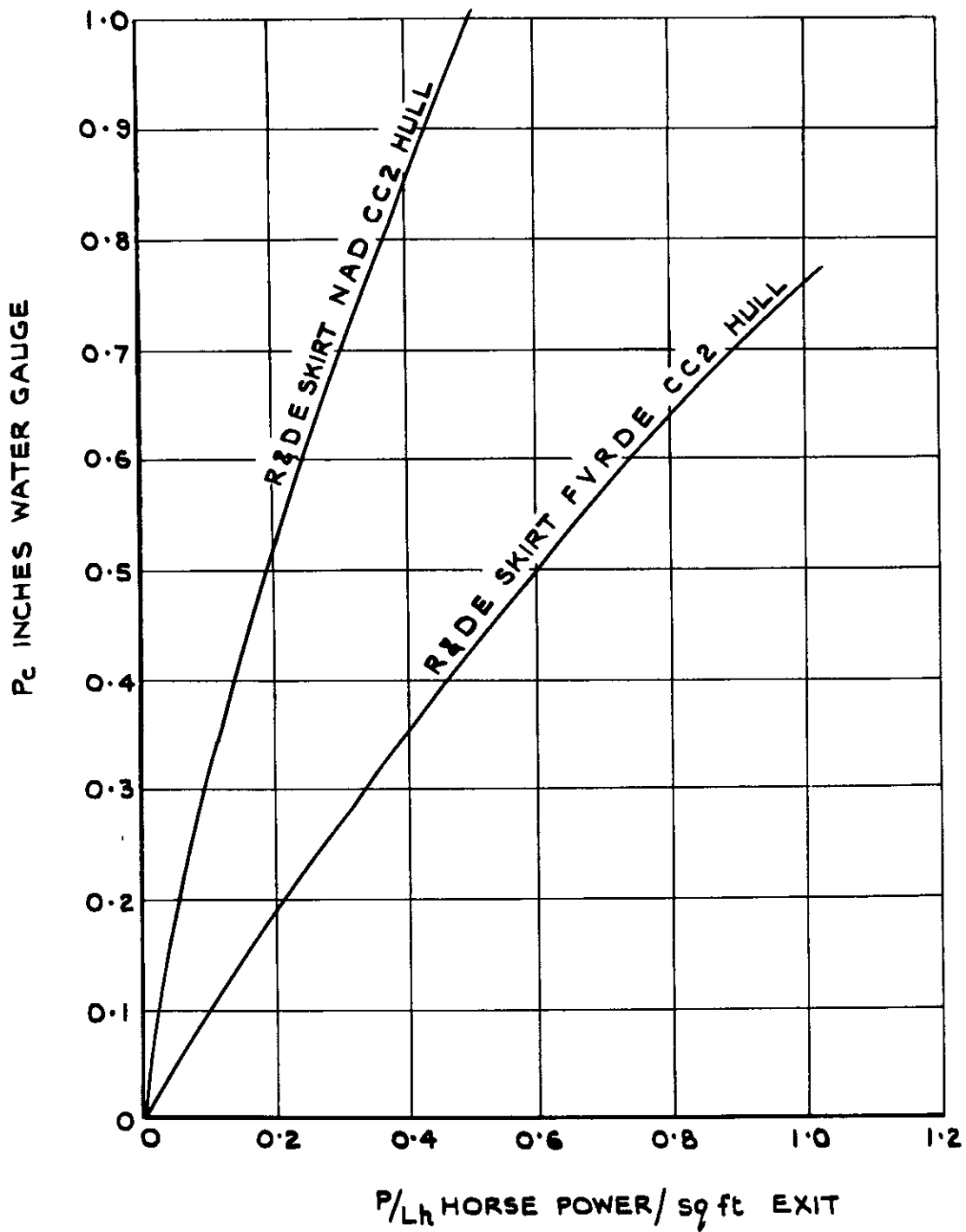

FIG.17 COMPARISON OF THE PERFORMANCE OF THE SAME FABRIC SKIRT COMBINED WITH TWO DIFFERENT HULL CONFIGURATIONS

A.R.C. C.P. No. 990
February 1966

629.136.8 :
629.13.012.124

Lester, W.G.S.
Kiernan, F.T.

A NOTE ON SOME STATIC TESTS OF FLEXIBLE SKIRTS FOR HOVERCRAFT

A series of static tests conducted to establish an efficient form of flexible skirt for a peripheral jet type of hovercraft is reported. The importance of designing the peripheral jet system in conjunction with the skirt is demonstrated. The results suggest that the effective width of a flexible nozzle is less than its actual width and the discharge coefficient requires determining experimentally for each configuration. It is concluded that skirt configuration performance is best compared on the basis of power input to a skirt to generate a given cushion pressure for a specified daylight clearance. The results confirm that the skirt input power per unit exit area, based on daylight clearance and jet length, is directly proportional to (cushion pressure)^{3/2}.

A.R.C. C.P. No. 990
February 1966

629.136.8 :
629.13.012.124

Lester, W.G.S.
Kiernan, F.T.

A NOTE ON SOME STATIC TESTS OF FLEXIBLE SKIRTS FOR HOVERCRAFT

A series of static tests conducted to establish an efficient form of flexible skirt for a peripheral jet type of hovercraft is reported. The importance of designing the peripheral jet system in conjunction with the skirt is demonstrated. The results suggest that the effective width of a flexible nozzle is less than its actual width and the discharge coefficient requires determining experimentally for each configuration. It is concluded that skirt configuration performance is best compared on the basis of power input to a skirt to generate a given cushion pressure for a specified daylight clearance. The results confirm that the skirt input power per unit exit area, based on daylight clearance and jet length, is directly proportional to (cushion pressure)^{3/2}.

A.R.C. C.P. No. 990
February 1966

629.136.8 :
629.13.012.124

Lester, W.G.S.
Kiernan, F.T.

A NOTE ON SOME STATIC TESTS OF FLEXIBLE SKIRTS FOR HOVERCRAFT

A series of static tests conducted to establish an efficient form of flexible skirt for a peripheral jet type of hovercraft is reported. The importance of designing the peripheral jet system in conjunction with the skirt is demonstrated. The results suggest that the effective width of a flexible nozzle is less than its actual width and the discharge coefficient requires determining experimentally for each configuration. It is concluded that skirt configuration performance is best compared on the basis of power input to a skirt to generate a given cushion pressure for a specified daylight clearance. The results confirm that the skirt input power per unit exit area, based on daylight clearance and jet length, is directly proportional to (cushion pressure)^{3/2}.

6.11.11

11.11.11

11.11.11

11.11.11

11.11.11

11.11.11

11.11.11

11.11.11

11.11.11

C.P. No. 990

© *Crown Copyright* 1968

Published by
HER MAJESTY'S STATIONERY OFFICE

To be purchased from
49 High Holborn, London w.c.1
423 Oxford Street, London w.1
13A Castle Street, Edinburgh 2
109 St. Mary Street, Cardiff
Brazennose Street, Manchester 2
50 Fairfax Street, Bristol 1
258-259 Broad Street, Birmingham 1
7-11 Linenhall Street, Belfast 2
or through any bookseller

C.P. No. 990

S.O. CODE No. 23-9017-90